



## ***WOMEN FOR AFGHAN WOMEN***

### ***REQUEST FOR QUOTATION - RFQ- 0332***

*Construction of Boundary Wall, Mandi Mixed Primary School Paroon Center, in Nuristan Province, Afghanistan*

---

## 1) Summary

<b>RFQ Number</b>	<b>WAW/KBL/RFQ-0332</b>
<b>Announcement Type</b>	Open Tender
<b>Tender Title</b>	Construction of Boundary Wall, Mandi Mixed Primary School, Paroon Center, Nuristan Province, Afghanistan
<b>Issue Date</b>	04/09/2024
<b>Deadline for Bid Submission</b>	22/09/2024 9:30 AM in the morning, Kabul local time.

## 2) Introduction to Organization

Women for Afghan Women Organization (WAWO) is a grassroots civil society organization. It is a non-governmental, non-profit, non-affiliated to any political party, and follows the law of Non-governmental organizations and other prevailing laws of the country.

Women for Afghan Women Organization (WAWO) is a grassroots, civil society organization; our mission is dedicated to securing and protecting the rights of disenfranchised Afghan women and girls, particularly their rights to develop their potential, to self-determination, and to be represented in all areas of life: political, social, cultural and economic. We advocate for women's rights and challenge the norms that underpin gender-based violence wherever opportunities arise to influence attitudes and bring about change.

## 3) Tender Purpose and Expected Results

**“Women for Afghan Women Organization-WAWO”** is seeking for construction Company with the below specifications for the **Construction of Boundary Wall, Mandi Mixed Primary School, Paroon Center, Nuristan Province, Afghanistan**

In order to participate and be eligible, you will need to complete the necessary documents and attend the bid opening process. Please note the deadline for the bid submission, bid opening and submit your quotation. Incomplete submissions will automatically be rejected.

## 4) Language of Bid

4.1 The bid, as well as all correspondence and documents relating to the bid shall be written in English.

4.2 Supporting documents may be in another language accompanied by an accurate translation of the relevant passages in English (if required)

**5) Documents Comprising for the quotation.**

The Supplier shall complete and submit the following document with the quotation:

1. The attached bill of quantity with your cost.
2. Copy of your company AISA registration certificates
3. Company profile and previous experience.
4. List of similar projects implemented by the company.
5. Contracts of similar projects and related amounts.
6. Similar project completion certificate and donor contact information.
7. Tax clearance letter for the year 2022.
8. List of key teams (full name, last Name, Position and contact detail)
9. CV of the Key Staff with documents. (one project manager and one QA engineer)
10. List of construction equipment with proof of ownership/lease agreement.
11. Timetable for 4 months
12. Bank Account Detail.

**Note:**

1. Quotation must be completed without any changes to the format, no substitutes shall be accepted
2. All blank spaces shall be filled with the requested information.

## 6) Eligibility for Application

To complete the tasks successfully, the Firm/companies are expected to have the following experience:

1. The company must be registered with AISA.
2. Over three years of experience in implementation of similar projects with national and international organizations.  
Implemented at least one similar project worth of 250,000 AFN during the last 5 years
3. Experience with/knowledge of national and or international organizations and UN standards.

## 7) Payment Terms and Bid Price for Service Contract:

- 7.1 The payments will be made after confirmation of the work – by **WAWO and respective Supervision Engineers.**
- 7.2 Bid price should be made individually and as whole in the summary.
- 7.3 All duties, taxes and other payable will be paid by the contractor under the contract and shall be included in the total bid price submitted by the bidder.
- 7.4 **WAWO** will deduct the applicable tax as required by Afghanistan tax Law and will make the direct deposit to the Da Afghanistan Bank and make a clearance with the Ministry of Finance at the end of the year and monthly basis accordingly.
- 7.5 **WAWO** is not responsible for all taxes of the project. The contractor has to pay all the taxes according to the rules and regulations of Afghanistan law.
- 7.6 According to Article No 73 of Income Tax law of 1384 amended to Article No 72 the Client will withhold.
- 7.7 2% of contract value, if the Contractor holds a valid business license from the relevant sources.
- 7.8 7% of the contract value, if the Contractor does not have a valid business license or expired business, or any other tasks for which the contractor aren't able to provide the business license.

## 8) Currencies of Bid and Payment:

All invoices will be paid in AFN. All payments will be transferred through the banking system/ Wire transfer and the payment will be processed and released within maximum 30 calendar days after submission of the invoice and confirmation of the work by WAW and completing the required paper work to the business bank account of the contractor

## 9) Performance Guarantee

9.1 The Successful bidders shall furnish "Performance Guarantee" an amount equivalent to 10% of total bid price before signing the contract.

9.2 The Performance Guarantee shall be a Bank Guarantee in favor of UNICEF from a well-established Bank, legally operating in Afghanistan and acceptable to UNICEF.

9.3 The Performance Guarantee shall be valid for 6 months from the date of signing the contract.

9.4 The Performance Guarantee will be released upon issuance of Substantial Completion Certificate by the Client.

10.19.5 UNICEF as Client shall not pay any interest for such Performance Guarantees.

## 10) Retention Money

10.1 UNICEF shall deduct 10% amount from each invoice as Retention Money (RM). The maximum amount of Retention Money so deducted will be 10% of the contract value.

10.2 The RM will be retained with UNICEF as a Security Bond for Defect Liability Period and will be released after successful expiry of 6 months DLP for the renovation works

10.210.3 UNICEF will not pay any interest on the retention money.

## 11) Terms of Contract:

The following terms of the contract must be applicable for further payment and bidder contracts:

- i. A copy of the AISA Certificate along with the TIN number or registration certificate from Authorized governmental agencies needs to be submitted along with the quotation.
- I. Your quotation will be accepted, and payment will be proceeding as per your legal business title.
- ii. **WAWO** will pay a crossed cheque in favor of the valid bank account of the organization/individual with whom the contract is executed. Any other bank account is not acceptable.
- iii. Penalty applies to the selected company in case of late delivery as per of our contact policy and procedures.
- iv. Valid Bank account according to your legal business title.
- v. Quotation should be signed and stamped from your side.
- vi. **WAWO** reserves the right to cancel this process without further notice to the vendors.

**12) Submission:**

Please submit your bids in accordance with the requirements detailed below:

This RFQ contains two types of proposals: 1). Technical Proposal, and 2). Financial Proposal. The Bidders shall complete and submit both proposals in sealed envelope clearly writing on the envelope as Technical Proposal and Financial Proposal respectively. The two separate proposals Technical and Financial should be put inside a single envelope with the RFQ number and Project Name clearly written on the envelope. The Financial Bid of only those bidders who qualify in the Technical Evaluation will be opened for further evaluation.

Complete sealed bid documents should be submitted to WAWO Main Office, Kart-e-Char Street 2 (Taraki Street) Opposite Shams London Private High School, House No 07, Kabul Afghanistan.no later than Date: **22/09/2024, Time: 9:30 AM Afghanistan Kabul Time.**

If you have any further question or clarifications in this bid, please reach out by email to the following email id.

Email: [Procurement@womenforafghanwomen.org](mailto:Procurement@womenforafghanwomen.org)

**Pre-bid meeting will be held in person or through virtual in the following address, date and time:**

WAW Main Office, House # 07, In front of Shams London Academy, Taraki Street, Kart-e-Char, Kabul

Date: 16/09/2024

Time: 10:30 AM, Kabul time.

**Site Visit: -**

Bidders are **Encouraged** to visit the site. (a) **A site visit for the bidder will be organized by WAWO on 15/09/2024 at 10:30AM at Mandi Mixed Primary School, Paroon center, Nuristan Province, Afghanistan.**

[(a)/(b)] The Bidder is required to submit by [EMAIL/LETTER] at [Procurement@womenforafghanwomen.org](mailto:Procurement@womenforafghanwomen.org) the name of its representative for the site visit with contact details. The deadline for receipt of this information is **[15/09/2024, 10:00 AM).**

### **13) Eligible Bidders:**

Participation in tendering is open on equal terms to all companies/firms which is officially registered with the Government of Afghanistan. The bidder at the time of submission of the bid should not be:

- II. insolvent.
- III. in receivership.
- IV. bankrupt; or
- V. being wound up.

### **14) Inspection and late proposal:**

**WAWO** is obliged to ensure that its procurement decisions are clearly justified and documented, within the Donors mandatory principles that full and on-the-spot access must be granted to representatives of **WAWO**, Donor, any organization or person mandated by it, to premises belonging to **WAWO** or its contractors. The right to access shall include all documents and information necessary to assess or audit the implementation of the contract.

Tenders must be submitted by the due date and time as specified under para-10. Tenders received after the due date will not be considered unless, in **WAWO's** sole opinion, there are exceptional circumstances which have caused the delay. **WAWO**, One Bidder cannot get more than one school in case they apply for all packages.

Clear breakdown of costs related to items and services as requested in RFQ, and a detailed price list for all the services linked to the technical requirement.

The bidder will have affected by no potential conflict of interest, and we and our staff have no particular link with other Tenderers or parties involved in this competition. Should such a situation arise during the performance of the contract, we shall immediately inform **WAWO** in written.

### **15) Compliance and Rejection of Tenders:**

**WAWO** reserves the right to reject all bids not submitted in the format specified and any bids where any of the required forms are not completed. Therefore, the **WAWO** is under no obligation to accept any tender.

### **16) Clarification of Bidding Documents:**

A prospective bidder requiring any clarification of the bidding document shall contact the **WAWO** in writing before 7 days of the date of bid submission specified under para-10.

The organization will respond in writing to any request for clarification before the deadline for clarification of bids. The **Women for Afghan Women Organization (WAWO)** shall forward copies

of its response to all bidders who have acquired the bidding document, including a description of the inquiry but without identifying its source.

**17) Bid Validity:**

Bids shall remain valid for **60 days** from the date of the bid submission deadline date as specified under para-10. A bid valid for a shorter period shall be rejected as non-compliant.

**18) Sealing and Marking of the Bidding Documents by the Bidder:**

1. The bidder shall enclose the bid for each contract in a plain envelope securely sealed.

Be addressed to the

**WAW Main Office, House # 07, Infront of Shams London Academy, Taraki Street, Kart-e-Char, Kabul**

2. Bear the bid number.
3. No other markings should be on the envelope.
4. If any envelope is not sealed and marked as required, those bids will be rejected.
5. Bidder should send WhatsApp Message to the Number 0799987324 upon the submission including the name of company, date of submission, Name of the schools, Name of Partner (NGO) and Photo of the envelope.

**19) Confidentiality:**

- A. Bidders must treat the invitation to tender, and all associated documentation supplied as confidential.
- B. Information relating to the examination, evaluation, comparison, and post-qualification of bids, and recommendation of contract award, shall not be disclosed to bidders or any other persons not officially concerned with such process until information detailing the best evaluated bidder is communicated to all bidders.
- C. Any effort by a bidder to influence the **WAWO** in the examination, evaluation, comparison, and post-qualification of the bids or contract award decisions may result in the rejection of its bid.

**20) Process of Bid:**

The **WAWO** shall examine the legal documentation and other information submitted by bidders to verify eligibility, and then will review and score bids according to the following criteria:

Sl.No.	Award Criteria	Percentage (%) of Scoring
1.0	Past relevant experience and similar project (construction & renovation of building or schools) implemented during the last 5 years (2019 – 2023) <ul style="list-style-type: none"> <li>• 5 projects and above – 50%</li> </ul>	50 %



	<ul style="list-style-type: none"> <li>• 4 projects – 40%</li> <li>• 3 projects – 30%</li> <li>• 2 projects – 20 %</li> <li>• 1 project – 10%</li> </ul>	
2.0	<b>Company Capacity</b> <ul style="list-style-type: none"> <li>• Key personnel (at least one project manager and one QA engineer) – 25% (15% for PM &amp; 10% for QA Engineer)</li> <li>• List of construction equipment - 5%</li> <li>• Company structure/profile – 10%</li> </ul>	40 %
3.0	On time Delivery (timetable 4 months)	10%
	<b>Total Scoring</b>	<b>100 %</b>

*Note: In order to quality, bidders should attain a minimum score of 70% in the technical evaluation.*

**21) Notification and Signing of the Contract:**

Upon receipt of the Letter of Acceptance, the **WAWO** shall call the successful bidder to sign the Contract and return back to the organization. A copy of the contract will be provided to the bidder at the same time.

**22) Scope of Work:**

The scope of work is outlined in the Bill of Quantities (BoQ) and drawings attached to this bid.

**23) GENERAL REPRESENTATIONS**

By submitting its bid in response to this request, the Bidder confirms to WAWO as of the Submission Deadline.

21.1) The Bidder has (a) the full authority and power to submit the Bid and to enter into any resulting contract, and (b) all rights, licenses, authority, and resources necessary, as applicable, to develop, source, and supply the works and to perform its other obligations under any resulting contract. (c) the Bidder has not and will not enter into any agreement or arrangement that restrains or restricts any person’s rights to use, sell, dispose of, or otherwise deal with any service, deliverable, or outcome that may be acquired under any resulting contract.

21.2) All of the information it has provided to UNICEF concerning the works and the Bidder is true, correct, accurate, and not misleading.

21.3) The Bidder is financially solvent and is able to supply the works to UNICEF in accordance with the requirements described in this Bid.

21.4) The use or supply of the works does not and will not infringe any patent, design, tradename or trade-mark.

21.5) The development and supply of the works have complied, do comply, and will comply with all applicable laws, rules, and regulations.

21.6) The Bidder will fulfill its commitments with the fullest regard to the interests of **WAWO and** will refrain from any action that may adversely affect the donors funding this project - **UNICEF or the United Nations.**

21.7) It has the personnel, experience, qualifications, facilities, financial resources, and all other skills and resources to perform its obligations under any resulting contract.

21.8) The Bidder agrees to be bound by the decisions of UNICEF, including but not limited to, decisions as to whether the Bidder's Proposal meets the requirements and instructions stated in this Bid and the results of the evaluation process.

## **22) ETHICAL STANDARDS**

**WAWO** requires that all Bidders observe the highest standard of ethics during the entire solicitation process, as well as the duration of any contract that may be awarded as a result of this solicitation process.

**WAWO, UNICEF and Donors** also actively promote the adoption by its suppliers of robust policies for the protection and safeguarding of children and the prevention and prohibition of sexual exploitation and sexual abuse.

By submitting its Proposal in response to this Bid, the Bidder makes the following representations and warranties to **WAWO** as at the Submission Deadline:

22.1) In respect of all aspects of the solicitation process the Bidder has disclosed to UNICEF any situation that may constitute an actual or potential conflict of interest or could reasonably be perceived as a conflict of interest. In particular, the Bidder has disclosed to **WAWO** if it or any of its affiliates is or has been in the past, engaged by **WAWO** to provide services for the preparation of the design, specifications, cost analysis/estimation, and other documents to be used for the procurement of the works requested under this RFPS; or if it or any of its affiliates has been involved in the preparation and/or design of the program/project related to the works requested under this Bid.

22.2) The Bidder has not unduly obtained, or attempted to unduly obtain, any confidential information in connection with the solicitation process and any contract that may be awarded as a result of this solicitation process.

23.3) No official of **WAWO, UNICEF, or any United Nations System organization** has received from or on behalf of the Bidder or will be offered by or on behalf of the Bidder, any direct or indirect benefit in connection with this RFPS including the award of the contract to the Bidder. Such direct or indirect benefit includes, but is not limited to, any gifts, favors, or hospitality.

23.4) Neither the Bidder nor any of its affiliates, or personnel or directors, is subject to any sanction or temporary suspension imposed by any United Nations System organization or other international inter-governmental organization such as the Asian Development Bank, European Union, etc. The Bidder will immediately disclose to **WAWO, and UNICEF** if it or any of its affiliates, or personnel or directors, becomes subject to any such sanction or temporary suspension during the term of the contract.

If the Bidder or any of its affiliates, or personnel or directors becomes subject to any such sanction or temporary suspension during the term of any resulting contract, **WAWO will** be entitled to suspend the contract for a period of time up to thirty (30) days or terminate the contract, at its sole choice, with immediate effect upon delivery of a written notice of suspension or termination, as the case may be, to the Bidder.

If **WAWO** chooses to suspend the contract it will be entitled to terminate the contract at the end of the thirty (30) days' suspension at (**WAWO**) sole choice.

23.5) The Bidder will

(a) observe the highest standard of ethics.

(b) use its best efforts to protect **WAWO and UNICEF** against fraud, in the solicitation process and the performance of any resulting contract; and

(c) comply with the applicable provisions of UNICEF's Policy Prohibiting and Combatting Fraud and Corruption which can be accessed on the UNICEF website at <https://www.unicef.org/supply/resources/procurement-policies>.

In particular, the Bidder will not engage, and will ensure that its personnel, agents and sub-contractors do not engage, in any corrupt, fraudulent, coercive, collusive or obstructive conduct as such terms are defined in UNICEF's Policy Prohibiting and Combatting Fraud and Corruption.

23.6) The Bidder will comply with all laws, ordinances, rules and regulations bearing upon its participation in this solicitation and the UN Supplier Code of Conduct (available at the United Nations Global Marketplace website - [www.ungm.org](http://www.ungm.org)).

23.7) Neither the Bidder nor any of its affiliates, is engaged, directly or indirectly, (a) in any practice inconsistent with the rights set forth in the Convention on the Rights of the Child, including Article 32, or the International Labour Organization's Convention Concerning the Prohibition and Immediate Action for the Elimination of the Worst Forms of Child Labour, No. 182 (1999); or (b) in the manufacture, sale, distribution, or use of anti-personnel mines or components utilized in the manufacture of anti-personnel mines.

23.8) The Bidder has taken and will take all appropriate measures to prevent sexual exploitation or abuse of anyone by its personnel including its employees or any persons engaged by the Bidder to perform any works and services in the Bidder's participation in this solicitation. For these purposes, sexual activity with any person less than eighteen years of age, regardless of any laws relating to consent, will constitute the sexual exploitation and abuse of such person. The Bidder has taken and will take all appropriate measures to prohibit its personnel including its employees or other persons engaged by the Bidder, from exchanging any money, goods, services, or other things of value, for sexual favors or activities or from engaging in any sexual activities that are exploitive or degrading to any person.

23.9) The Bidder confirms that it has read UNICEF's Policy on Conduct Promoting the Protection and Safeguarding of Children. The Bidder will ensure that its Personnel understand the notification requirements expected of them and will establish and maintain appropriate measures to promote compliance with such requirements. The Bidder will further cooperate with UNICEF's implementation of this Policy.

23.10) The Bidder will inform **WAWO** as soon as it becomes aware of any incident or report that is inconsistent with the undertakings and confirmations provided in this Article 22 and 23 Each of the provisions in this Article 22 and 23 constitutes an essential condition of participation in this solicitation process. In the event of a breach of any of these provisions, **WAWO** is entitled to disqualify the Bidder from this solicitation process and/or any other solicitation process, and to terminate any contract that may have been awarded as a result of this solicitation process, immediately upon notice to the Bidder, without any liability for termination charges or any liability of any kind. In addition, the Bidder may be precluded from doing business with **WAWO UNICEF** and any other entity of the United Nations System in the future.

#### **24. AUDIT CONSTRUCTION WORKS**

From time to time, (**WAWO**) and/or UNICEF may conduct audits or investigations relating to any aspect of a contract awarded in relation to this bid, including but not limited to the award of the contract and the Bidder's compliance with the provisions of Article 22 and 23 above. The Bidder will provide its full and timely cooperation with any such audits or investigations, including (but not limited to) making its personnel and any relevant data and documentation available for the purposes of such audits or investigations, at reasonable times and on reasonable conditions, and granting **WAWO**, UNICEF and those undertaking such audits or investigations access to the Bidder's premises at reasonable times and on reasonable conditions in connection with making its personnel and any relevant data and documentation available. The Bidder will require its sub-contractors and its agents to provide reasonable cooperation with any audits or investigations carried out by **WAWO and UNICEF**

#### **25) Environmental, Social, Health, and Safety (ESHS)**

Bidders, if successful in this bid and are awarded the contract, should adhere to the following: -

- shall ensure that the planned activities will be carried out within the current school's footprint, involving no land acquisition. The sanitary facilities should be at least 50 meters from classrooms and public property, and at least 25 meters away from potable/surface water. If there is not sufficient space, the location of the sanitary facilities should be selected with consideration of wind direction to prevent odors from spreading to the classrooms and surrounding environment. Additionally, the sanitary facilities should be in areas that can be easily supervised and evenly distributed throughout the school operation.
- shall ensure that the project's operations won't result in the cutting down of trees or the mutilation, slashing, or tampering with of the surrounding environment. In the event that there is not sufficient space, the contractor shall plant three trees in the current school's footprint in place of each cut tree.

- shall save all existing structures, pipes, cables, sewers, or other services or installations during the project implementation.
- shall ensure that all waste generated by contractor camp operations, excavation, and construction activities is managed properly and disposed of appropriately in the designated site by the local governor or municipalities.
- shall ensure that the environmental, social, health, and safety (ESHS) requirements (**Annex-4**) and proposed mitigation measures are put into place during the construction activities in order to manage, mitigate, minimize, and reduce the pollution of the air, water, noise, and soil.
- shall ensure that a site-specific occupational health and safety (OHS) management plan is developed and implemented during the project's construction phase. This plan should include information on the organization and capacity, roles and responsibilities, personnel protective equipment, compensation based on Afghanistan's national labor laws and regulations, training, and capacity building.
- shall ensure that the project site is temporarily fenced with an entrance gate and a full-time guard. A project signboard and other safety messages should be installed at the entrance or at other appropriate locations in consultation with the site engineer.
- Shall ensure that no existing and functional property of the school, including furniture, is damaged during implementation. The contractor shall be held responsible for repairing or replacing any such damages if it is conclusively proven that the contractor caused them.
- shall ensure that appropriate incident and accident reporting and handling procedures have been established, including those for internal and external reporting, first aid, compensation, and training for both technical and non-technical workers.
- shall ensure for the safety of their workers, locations, possessions, and operations. They shall ensure that their employees receive sufficient training on safety and security issues that are appropriate for the Afghan context, including conflict-sensitive communication, cultural awareness, implementation, and risk management, and they must immediately communicate to UNICEF any security-related issues that have a negative impact on program delivery or personnel.
- shall ensure that a site-specific Traffic Management Plan (TMP) is developed and implemented during the project construction phase and includes responsibilities, emergency response and reporting procedures, compensation based on Afghanistan's national labor laws and regulations, training, and capacity building for all drivers and other relevant employees.

- shall ensure that a site-specific emergency preparedness and response (EPR) plan is developed and implemented, all technical and non-technical employees and staff are trained. The plan should include roles and duties, emergency response procedures, internal and external reporting procedures.
- shall implement a combination of behavioral and environmental modification to mitigate communicable disease risks and impacts.
- shall ensure that both the project site and the contractor camp have adequate lavatory facilities (toilets and washing places), and that portable and drinking water are properly provided for project workers.
- shall ensure that before, during, and after the project's implementation, every relevant stakeholder, including provincial and district level MoE directorates, community representatives, Schools Management Shuras (SMS), and school's principals, are engaged and involved.
- shall ensure that a grievance system including the PSEA hotline and the PSEA confidential email address is set up at the project level and that all communities, teachers, and project workers (technical, skilled, and unskilled labor) are properly informed of the reporting channels and handling procedures. In addition, UNICEF will encourage the use of its innovative SMS-based mechanisms (U-Report and RapidPro), as well as the interagency system Awaaz, to receive feedback from impacted populations.
- shall ensure that a project labor management procedure is in place, that all technical and non-technical worker terms and conditions comply with Afghanistan labor laws and regulations, that they are informed of the project grievance procedure, and that no child or forced labor is employed in the project activities.
- shall ensure the availability of a functional grievance redressal mechanism at the project level that can be used as a reporting channel with specific referral pathways for GBV/SEA/SH. As well as ensure that all project workers (technical and non-technical staff) receive training on sexual exploitation and abuse and sign a code of conduct.
- shall ensure that all project employees, both technical and non-technical, receive continuous capacity-building training on minimizing environmental and social risks and managing their effects.
- the contractor will be in charge of setting up an ESS focal point and will be in charge of implementing the social and environmental safeguards instruments in the project site.

**ANNEX-1**  
**Bill of Quantities (BoQ)**

Please Fill the BoQ properly and give your rate for each item. The contractors are requested to visit the site prior to fill the BoQ

## ANNEX-2

### BIDDING FORM

---

#### Bidder's General Details:

##### a) General information:

Please fill in the below table with required information

Supplier/Company Name:	
Tazkira No./Company Registration No.	
Tazkira Issued /Country of Company Registration	
Nature of primary business/trade:	
Registration date: (only for Company)	
Expiry date: (only for Company)	
Legal status of company (eg. partnership, private limited company)	
Primary contact name:	
Job title (only for Company):	
Primary contacts address:	
Phone:	
Email:	

##### b) Owners/Managers:

Please fill in the below table with required information

Full Name	
Tazkira no	
Year of birth	
Place of birth	
Permanent Address	
Current Address	
Contact Detail (phone and email address)	



**Beneficiaries bank account details:**

Beneficiary name:		
Beneficiary account Number:		
Beneficiary Bank Name:		
Bank branch Name:		
SWIFT:		
Bank address:		

**Confirmation of Bidder’s compliance:**

I, the Bidder, hereby certify that our tender is a genuine offer and intended to be competitive and we confirm we are eligible to participate in public procurement and meet the eligibility criteria specified in the Invitation to Bid. We confirm that the prices quoted are fixed and firm for the duration of the validity period and will not be subject to revision or variation.

I, also confirm that I agree to all the terms and conditions specified in this bid. And also understand that these terms and conditions will apply to any subsequent contract that our company/firm will be signing in the event our bid is successful.

I confirm that **(WAWO)** may in its consideration of our offer, and subsequently, rely on the statements made herein.

Name of Signatory: -----

Title of signatory: -----

Signature: -----

Date of signing: -----

### ANNEX-3

#### TENDER COMPANY PROFILE AND PREVIOUS EXPERIENCE FORM

The Bidder is requested to:

1. Submit the **Company Profile**
2. Complete the following **Previous Experience Table** listing similar works or contracts undertaken during the last past 5 **years** (2019-2023)
3. Submit **evidence of previous similar work experience** in form of Contracts, Completion Certificates, Handover Documents etc. **for 5 years (2019-2023)**

No.	Name of Project / Type of work	Client name, email. Phone	Total value of the performed works (....)	Duration of the works contract	Starting date	Ending date	Contracting Authority and Place
1							
2							
3							
4							
5							

**NOTE:** A comprehensive list of the last 5 years' (2019 – 2023) experience has to be submitted adapting the Form to the necessary rows. WAWO may conduct reference checks for previous contracts complete.

#### ANNEX-4

## ENVIRONMENTAL, SOCIAL, HEALTH & SAFETY (ESHS)

See the attached annexure sent with the bid

This document outlines essential guidelines for the project. It specifies that the total cost quoted in the Bill of Quantities (BOQ) must cover the deployment of machinery and manpower, including any relocation, removal, salvage, or reinstatement tasks. Additionally, the costs for checks and testing of materials and items to be used should be incorporated within the unit costs of the relevant items. Specific cost concerns for items are detailed in the respective sections of this BOQ.

Before starting any work, it is mandatory to present the methods of work and the equipment/machinery intended for various tasks to the Engineer for approval. Contractors are also required to review all project documentation thoroughly before quoting prices.

The contractor is responsible for any fluctuations in market prices of items during the project, with no entitlement to extra payment. To ensure quality and safety, approval from the Client's Engineer is necessary for all finishing, electrical accessories, structural items, mechanical accessories/equipment, plumbing materials/items, and any other equipment mentioned in the BOQ before commencement of work or usage in the project. This approval process includes the submission of samples, product data from manufacturers, and certificates. Importantly, contractors must also submit the manufacturer's approval certificate from the production country for all major construction materials, along with the ISO certificate.

The contractor is obliged to provide samples, mockups, and catalogs for testing/inspection and gain approval from the site engineer. The costs for these samples, including any laboratory tests required domestically or internationally, will be borne by the contractor.

Lastly, the provision of Personal Protective Equipment (PPE) for all laborers, personnel, engineers, and site visitors is the responsibility of the contractor to ensure safety throughout the project duration.

**Mandi Mixed Primary School Center Paroon Nuristan Province**

**Priority 1 School Boundary Wall 193 ML**

**A - School Boundary Wall**

S.N	Description	Unit	Quantity	Unit price (AFN)	Total cast (AFN)	Remarks
A-1	<p><b><u>Excavation For Foundation</u></b>                      Prepare all materials, equipment, and manpower to excavate the boundary wall foundation, including (1.2X0.8)M all related activities to complete the job according to the drawing and instructions of the in-charge engineer. All tasks for this item must receive full approval from the in-charge engineer.</p>	Cub M	185.25			

**Mandi Mixed Primary School Center Paroon Nuristan Province**

**Priority 1 School Boundary Wall 193 ML**

<b>A - School Boundary Wall</b>		<b>Unit</b>	<b>Quantity</b>	<b>Unit price (AFN)</b>	<b>Total cast (AFN)</b>	<b>Remarks</b>
<b>S.N</b>	<b>Description</b>					
A-2	<p><b><u>Stone Masonry Work for Foundation and Kursi (1:5)</u></b>                      Prepare all materials, equipment, and manpower for stone masonry work with mortar (1:5 ratio), including all related activities to complete the job according to the drawing and instructions of the in-charge engineer. All tasks for this item must be fully approved by the in-charge engineer. Follow the steps below:</p> <p>a. Gather materials: cement, sand, water, stones.                      b. Mix mortar: Use a 1:5 cement-sand ratio.                      c. Mark the layout accurately based on provided drawings.                      d. Prepare the base layer if necessary for a solid foundation.                      e. Start laying stones from corners, applying mortar for bonding.                      f. Check the level and alignment regularly to ensure accuracy.                      g. Cure the masonry for 7 days to achieve optimal strength.                      Ensure strict adherence to the specified steps and maintain communication with the in-charge engineer for approval throughout the project.</p>	Cub M	279.85			

**Mandi Mixed Primary School Center Paroon Nuristan Province**

**Priority 1 School Boundary Wall 193 ML**

A - School Boundary Wall		Unit	Quantity	Unit price (AFN)	Total cast (AFN)	Remarks
S.N	Description					
A-3	<p><b><u>Plastering For Column for the Main Get Of Boundary Wall 1:4</u></b>                      Prepare all materials, equipment, and manpower for plastering the main gate column of the boundary wall, including all related activities required to complete the job according to the drawings and instructions provided by the in-charge engineer. Ensure that all tasks for this item receive full approval from the in-charge engineer.</p>	Suq M	11.24			
A-4	<p><b><u>PCC for the Top of Stone Masonry (Over Stone Masonry)+Shutaring</u></b>                      Prepare all materials, equipment, and manpower for PCC works, including all related activities, to ensure the job is completed in accordance with the drawings and instructions provided by the in-charge engineer. Every task associated with this item must receive the in-charge engineer's full approval.</p>	Cub M	23.44			
A-5	<p><b><u>RCC Concrete (1:1.5:3) for Column and Foundation withe Shutaring</u></b>                      Prepare all materials, equipment, and manpower for RCC work, along with all related activities, to ensure the job is completed in accordance with the drawings and instructions provided by the in-charge engineer. All tasks associated with this item must receive the in-charge engineer's full approval</p>	Cub M	4.28			
A-6	<p><b><u>Gate for the boundry wall, Metal profil with All Necessary Activities (Hinge, Frame, Oil Painting, and Installation)</u></b>                      Prepare all materials, equipment, and manpower for applying 3 coats of oil paint to the Main Gate, along with all related activities, to complete the job according to the drawings and instructions of the in-charge engineer. All tasks for this item must be under the full approval of the in-charge engineer."</p>	Suq M	9.24			

**Mandi Mixed Primary School Center Paroon Nuristan Province**

**Priority 1 School Boundary Wall 193 ML**

<b>A - School Boundary Wall</b>		<b>Unit</b>	<b>Quantity</b>	<b>Unit price (AFN)</b>	<b>Total cast (AFN)</b>	<b>Remarks</b>
<b>S.N</b>	<b>Description</b>					
A-7	<b><u>Pointing of Stone Masonry Wall on Both Sides with 1:3 Mortar Mix Ratio</u></b> Prepare all materials, equipment, and manpower for pointing the stone masonry wall on both sides, along with all related activities, to complete the job according to the drawings and instructions of the in-charge engineer. All tasks for this item must be under the full approval of the in-charge engineer	Suq M	656			
A-8	<b><u>Back Filling &amp; Compaction.</u></b> Prepare all materials, equipment, and manpower for Back Filling and compaction I on both sides, along with all related activities, to complete the job according to the drawings and instructions of the in-charge engineer. All tasks for this item must be under the full approval of the in-charge engineer	Cub M	61.76			
A-9	<b><u>Preparation and Leveling of school yard and site clearance</u></b> Preparation and leveling of a school yard, along with site clearance, are crucial steps in creating a safe and functional outdoor area for a school. This process involves several stages to ensure the ground is properly prepared for its intended use, whether it be for sports, playgrounds, or general outdoor activities.	Ls	1			
A-10	<b>Project Sign board as per the design. Supply and installation of project metallic signboard as per the instruction of the incharge engineer.</b>	EACH	1.00			
Sub Total A - Boundary Wall						

This document outlines essential guidelines for the project. It specifies that the total cost quoted in the Bill of Quantities (BOQ) must cover the deployment of machinery and manpower, including any relocation, removal, salvage, or reinstatement tasks. Additionally, the costs for checks and testing of materials and items to be used should be incorporated within the unit costs of the relevant items. Specific cost concerns for items are detailed in the respective sections of this BOQ.

Before starting any work, it is mandatory to present the methods of work and the equipment/machinery intended for various tasks to the Engineer for approval. Contractors are also required to review all project documentation thoroughly before quoting prices.

The contractor is responsible for any fluctuations in market prices of items during the project, with no entitlement to extra payment. To ensure quality and safety, approval from the Client's Engineer is necessary for all finishing, electrical accessories, structural items, mechanical accessories/equipment, plumbing materials/items, and any other equipment mentioned in the BOQ before commencement of work or usage in the project. This approval process includes the submission of samples, product data from manufacturers, and certificates. Importantly, contractors must also submit the manufacturer's approval certificate from the production country for all major construction materials, along with the ISO certificate.

The contractor is obliged to provide samples, mockups, and catalogs for testing/inspection and gain approval from the site engineer. The costs for these samples, including any laboratory tests required domestically or internationally, will be borne by the contractor.

Lastly, the provision of Personal Protective Equipment (PPE) for all laborers, personnel, engineers, and site visitors is the responsibility of the contractor to ensure safety throughout the project duration.

SN#	Items (Bill)	Cost (AFN)
1	A - School Boundary Wall 193 ML	





PROJECT NAME : Mandi Mixed Primary School  
PROJECT EMPLOYER : UNITED NATIONS CHILDREN'S FUND  
PREPARE BY : CONSTRUCTION SECTION

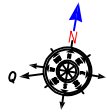

Legend of Site Plan: Mandi Mixed Primary School  
Province : Nuristan

A	Existing Building
B	Existing Latrines
C	Existing Septic T
D	Existing Hand Washing
E	New Boundary wall (193m)

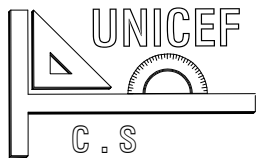
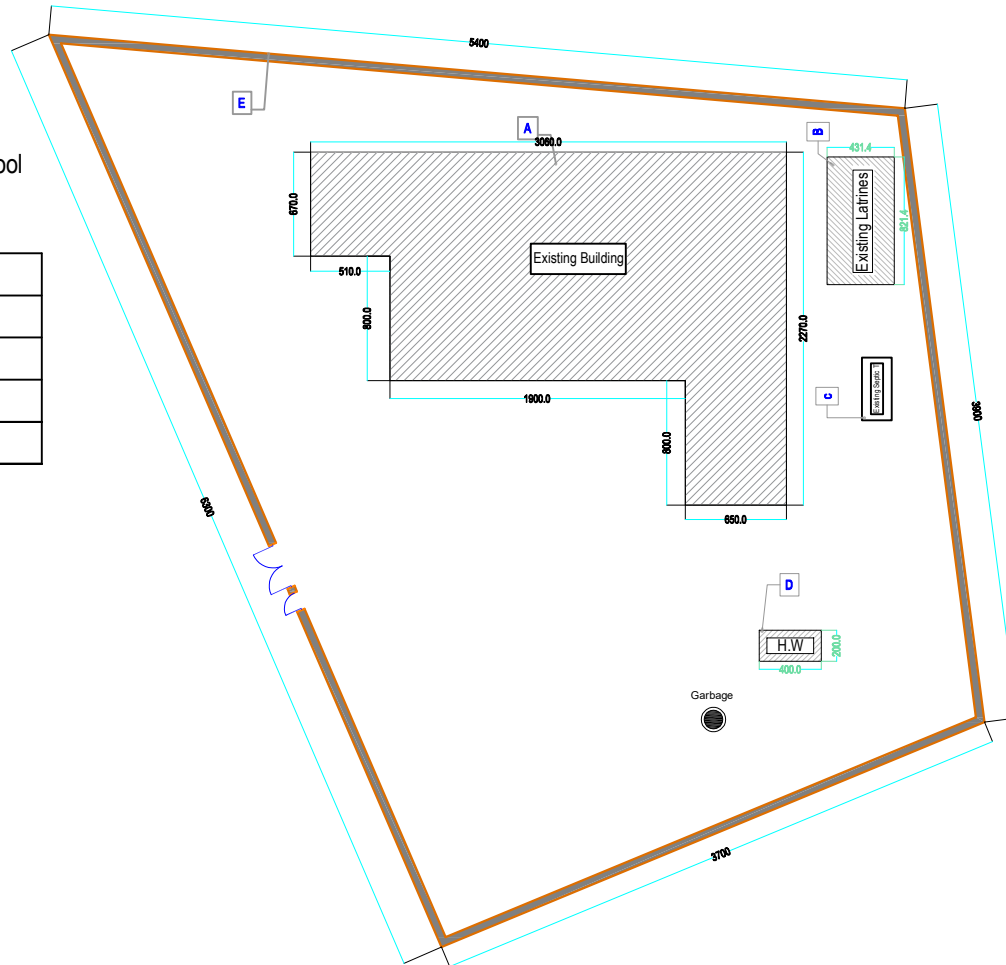

TITLE :

DRAWING BY

CHECKED BY

APPROVED BY

SHEET No 1

SCALE AS SHOWN

DATE Jan. 2024

PROJECT EMPLOYER  
UNITED NATIONS CHILDREN'S FUND

construction section

Mandi Mixed Primary School

All dimension are in cm



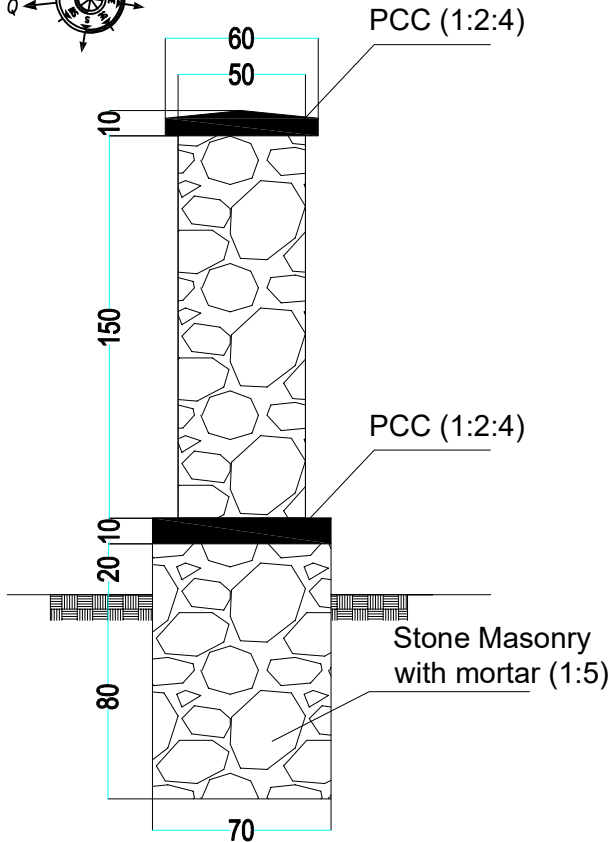
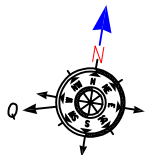

**Stone Boundary Wall**  
Section A-A

Legend of Site Plan: Mandi Mixed Primary School

Province : Nuristan

**Stone masonry Boundary Wall**

Elevation

3 cm Construction joint After 15-20 m

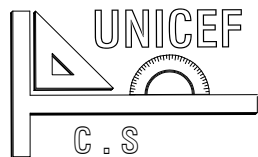
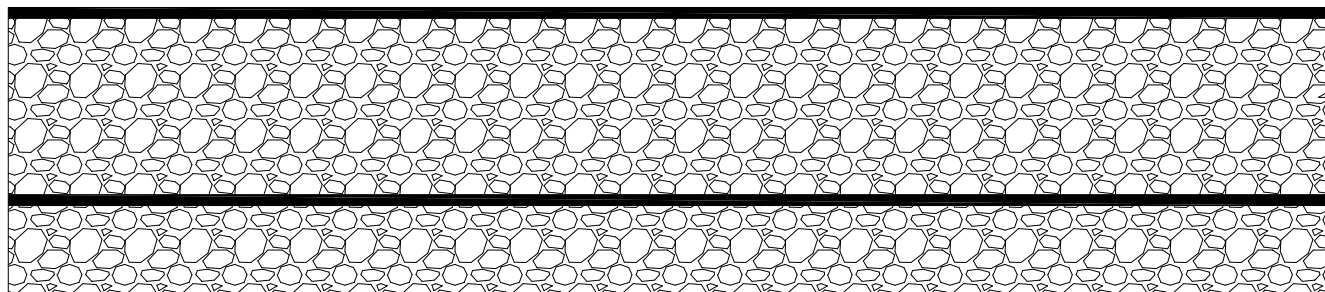

TITLE :

DRAWING BY

CHECKED BY

APPROVED BY

**PROJECT EMPLOYER**

**UNITED NATIONS CHILDREN'S FUND**

construction section

Mandi Mixed Primary School

All dimension are in cm



SHEET No 1

SCALE AS SHOWN

DATE Jan. 2024

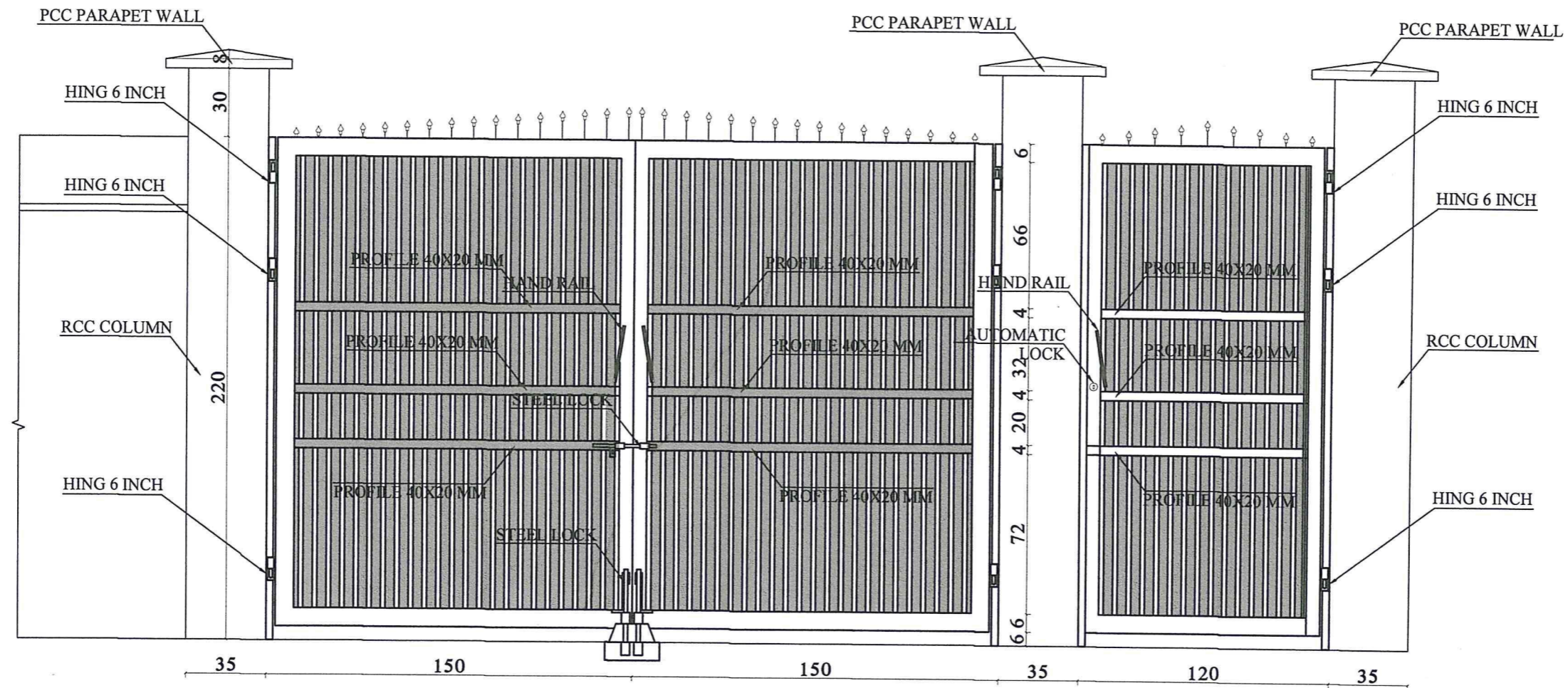

BACK ELEVATION

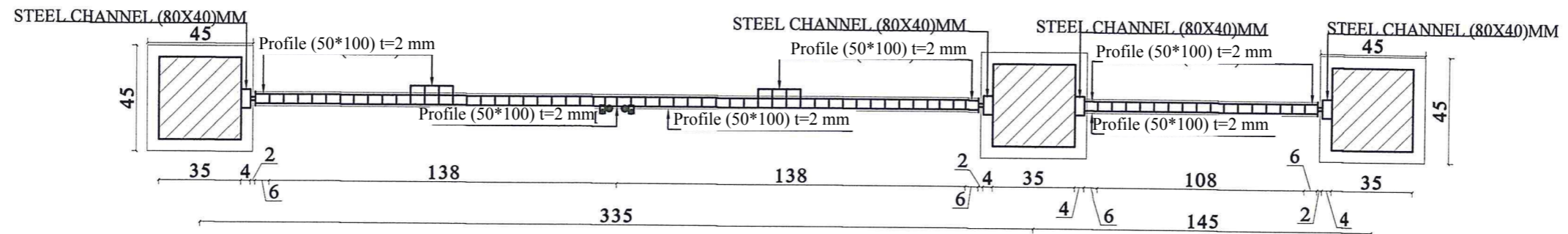

PLAN FOR DOORS

DOOR FOR CARS(300X220)CM

DOOR FOR STUDENT (120X220)CM



MINISTRY OF EDUCATION DEPARTMENT  
OF CONSTRUCTION



PROTOTYPE SCHOOL DESIGN IN  
AFGHANISTAN

ARCHITECT/DESIGN  
PREPLANNED &  
CHECKED BY  
TECH. APPROVED BY

M.DARWISH  
DAARTT

Combined technical  
team  
SCALE  
DATE

MOE/MRRD/DAARTT  
AS SHOWN (A3)  
07/08/2018

PROJECT NAME  
DRAWING TITLE

BRICK MASONRY BOUNDARY WALL  
MAIN GATE

SHEET NO.

A4  
7

**Column-1 /Nos-3**

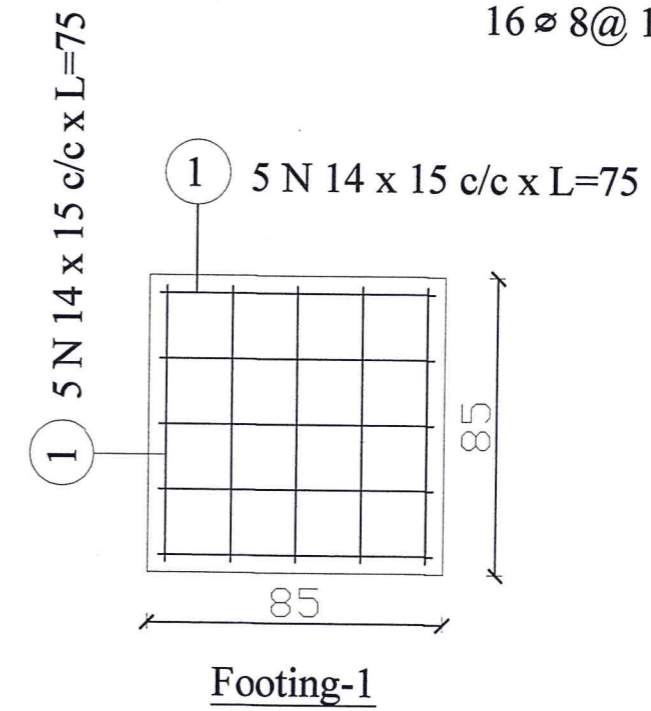
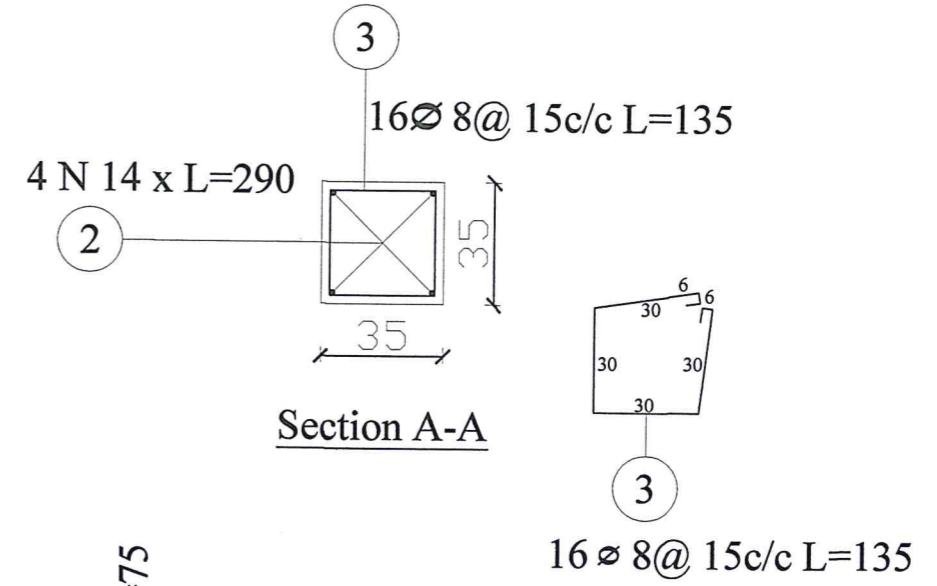
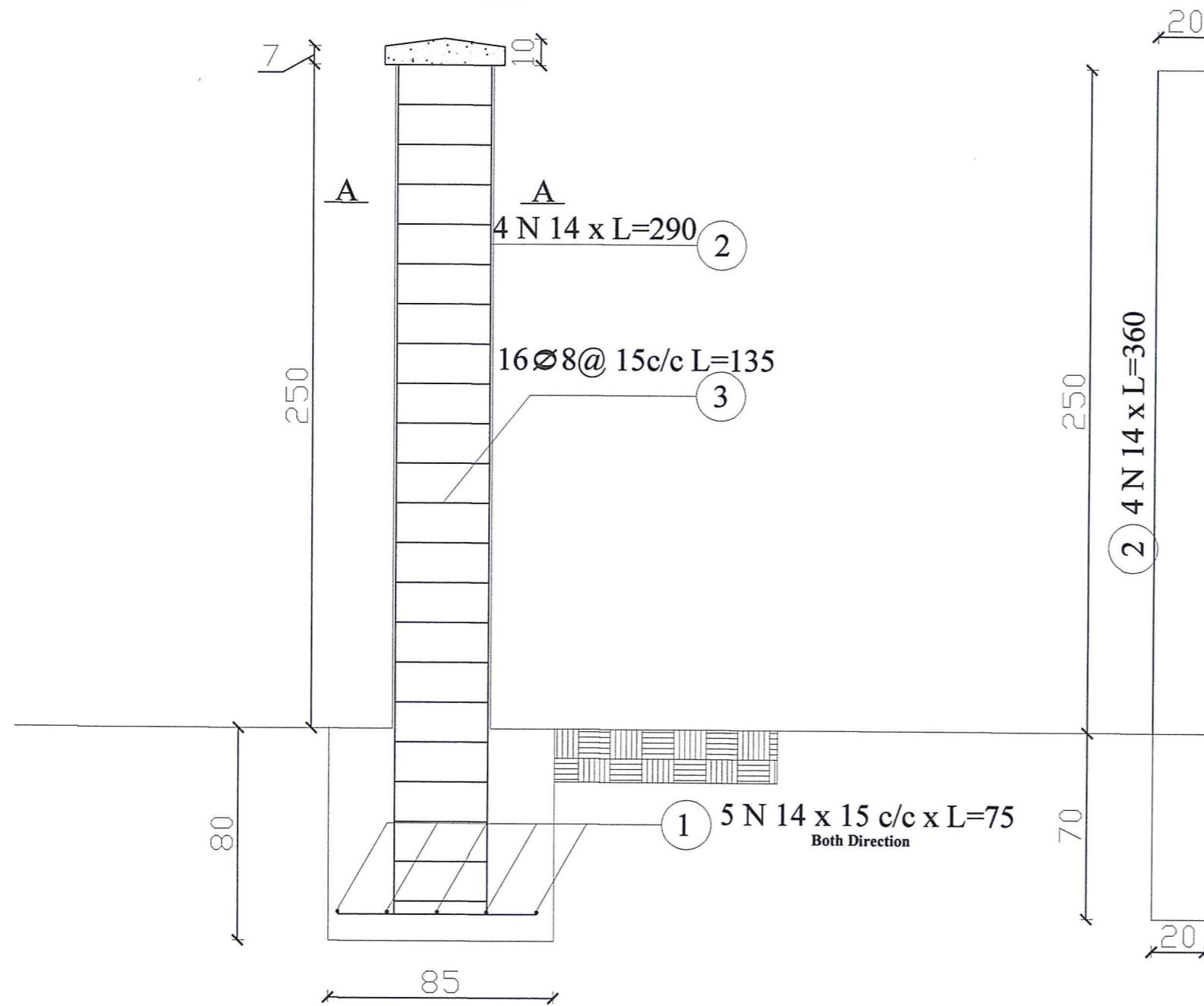

MINISTRY OF EDUCATION DEPARTMENT  
OF CONSTRUCTION



PROTOTYPE SCHOOL DESIGN IN  
AFGHANISTAN

ARCHITECT/DESIGN	M.DARWISH		Combined technical team	MOE/MRRD/DAARTT
PREPLANNED & CHECKED BY	DAARTT		SCALE	AS SHOWN (A3)
TECH-APPROVED BY			DATE	07/08/2018

PROJECT NAME BRICK MASONRY BOUNDARY WALL

DRAWING TITLE COLUMN FOOTING

SHEET NO.

A5  
7



Funded by the  
European Union



د هر ماشوم لپاره  
برای هر طفل

Name of the project	د پروژې نوم
Location of the project	د پروژې ځای
Start date	د پیل نېټه
Completion date	د پای نېټه
Funded by	تمویلونکې اداره
Implemented by	تطبیق کوونکې اداره



Funded by the  
European Union













د هر ماشوم لپاره  
برای هر طفل





















Name of the project	اسم پروژه
Location of the project	موقعیت پروژه
Start date	شروع کار
Completion date	ختم کار
Funded by	تمویل کننده
Implemented by	تطبیق کننده

## Nuristan School Location Map (22 Schools – 13 EU & 9 JICA)

### Districts

-  Kamdish (5)
-  Wama (5)
-  Bargematal (3)
-  DooAb (2)
-  Noor Geram (2)
-  Barge Matal (1)
-  Mandol (1)
-  Paroon Center (1)
-  Parun (1)
-  Waygal (1)

### School Names

-  Abdulwakeel Khan Mixed Se... (1)
-  Awlagul Primary School (1)
-  Badinshah Secondary school (1)
-  Bazgal Female Primary School (1)
-  Boni Mixed Primary School (1)
-  Dhane Palagal Girls Seconda... (1)
-  Dooaba Primary Mixed School (1)
-  Gad Wal Mixed Secondary S... (1)
-  Kamgul Coeducational Elem... (1)
-  Kordar Sufla Mixed Primary ... (1)
-  Mande Gul Girls Primary Sch... (1)
-  Mandi Mixed Primary School (1)
-  Nangal Boys school (1)
-  Nangal Female High school (1)
-  Nikmok Secondary Shool (1)
-  Nilab Girals High School (1)
-  Pachi gram Girls Secondary ... (1)
-  Pawla Mixed Primary School (1)
-  Titin Secondary Girals School (1)
-  Wadahu Secondary Girls Sch... (1)
-  Other / No value (2)

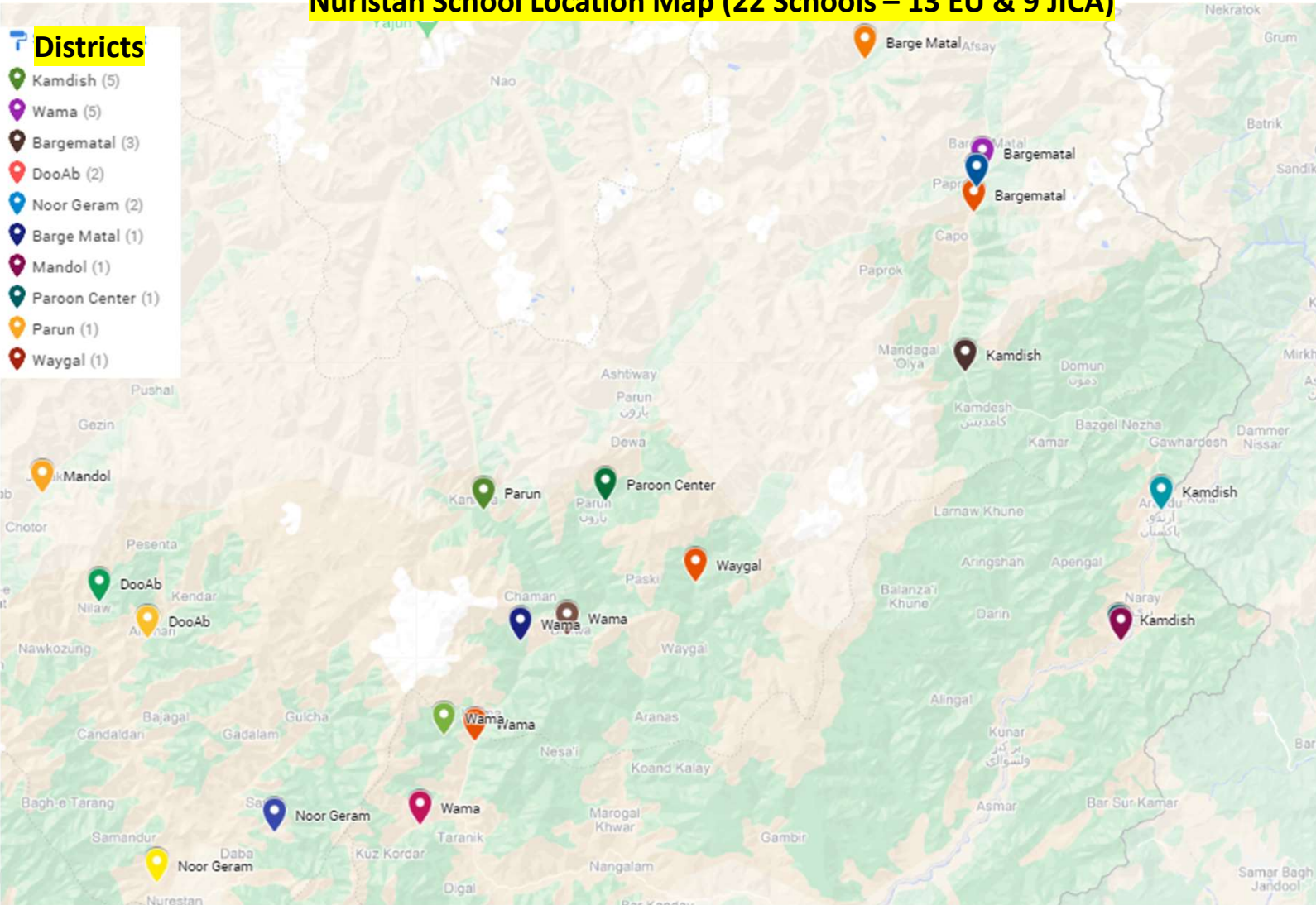

---

# STANDARD TECHNICAL SPECIFICATIONS

---

FOR CONSTRUCTION WORKS

DECEMBER 1, 2022  
UNICEF AFGHANISTAN COUNTRY OFFICE



## TABLE OF CONTENTS

TITLE	PAGE#
TABLE OF CONTENTS.....	1
SECTION 0105 - SUBMITTALS.....	3
SECTION 0106 - MINIMUM SAFETY REQUIREMENTS DURING CONSTRUCTION .....	3
SECTION 0107 - REPORTS, MEETINGS AND DATA OF THE WORKS .....	3
1.1 Monthly Report .....	3
1.2 Site/Work Meetings .....	4
SECTION 0108 - DISRUPTION OF LOCAL COMMUNITIES AND PROTECTION OF REAL ESTATE.....	4
SECTION 0109 - TEMPORARY FENCING .....	4
SECTION 0120 - CONTRACTOR'S CAMP .....	4
1. SCOPE.....	4
2. GENERAL.....	5
3. CODES AND STANDARD .....	5
4. MAINTENANCE.....	5
5. MEASUREMENT AND PAYMENT .....	5
SECTION 0150 - CLEARING AND GRUBBING .....	6
2. LIMIT OF AREA.....	6
3. PAYMENT OF WORK.....	6
SECTION – 0500, LANDSCAPING.....	6
SECTION 1100 - EARTHWORKS.....	8
1. SCOPE OF WORK.....	8
2. GENERAL .....	9
SECTION 1300 - STONE SOLING and STONE MASONRY .....	14
SECTION 2100 - FORMWORK.....	17
SECTION 2200 - REINFORCEMENT .....	23
SECTION 2300 - PLAIN AND REINFORCED CONCRETE .....	28
SECTION 2350 - PRECAST CONCRETE PAVERS.....	61
SECTION 3000 - STRUCTURAL STEEL WORKS .....	63
SECTION 3010 - STAINLESS STEEL MATERIAL & FINISHES .....	70

<b>SECTION 4200 –BRICK MASONRY .....</b>	<b>75</b>
<b>SECTION 4600 - CARPENTRY AND JOINERY .....</b>	<b>78</b>
<b>SECTION 6220 - ALUMINIUM AND PVC WORKS.....</b>	<b>86</b>
<b>SECTION 6250 - GLAZING .....</b>	<b>101</b>
<b>SECTION 6411 - WATERPROOFING &amp; BUILT-UP ROOFING .....</b>	<b>104</b>
<b>SECTION 6521 - CEMENT PLASTER.....</b>	<b>107</b>
<b>SECTION 6531- MARBLE.....</b>	<b>111</b>
<b>SECTION 6560 - FALSE CEILING .....</b>	<b>114</b>
<b>SECTION 6600 - FLOOR AND WALL FINISHES .....</b>	<b>117</b>
<b>SECTION 6700 - PAINTING.....</b>	<b>124</b>
<b>SECTION 6701 - TEXTURED / GRAFFITO WALL COATING .....</b>	<b>128</b>
<b>SECTION 7200 – BUILDING INSULATION .....</b>	<b>130</b>
1.0 Description and General Requirements.....	130
2.0 Materials.....	130
<b>SECTION 15000 PLUMBING .....</b>	<b>130</b>
1.0 Description and Requirement.....	130
<b>SECTION 2005 – WELL FOR DRINKING WATER .....</b>	<b>149</b>
1.0 Description and Requirement .....	149
1.2 Well Capacity and Water Quality Testing .....	150
1.3 Well Rehabilitation.....	151
<b>SECTION 7300 –BASIC MECHANICAL MATERIALS AND METHODS .....</b>	<b>152</b>
1.0 Description and Requirement.....	152
<b>SECTION 16000 BASIC ELECTRICAL MATERIALS AND METHODS.....</b>	<b>163</b>
1.0 Description and Requirement.....	163
<b>SECTION 17000- FIRE DETECTION AND FIRE ALARM SYSTEM.....</b>	<b>176</b>
<b>THE END .....</b>	<b>179</b>

## **SECTION 0105 - SUBMITTALS**

These specifications require that the Contractor submit to UNICEF or delegated consultancy firm, information, samples of materials or Drawings for review and approval prior to executing the work. The items to be submitted for review and approval by the Supervisor are generally referred to as "Submittals". The Contractor should read through these sections very carefully and understand the level of effort required to provide this information. It is also important that the Contractor plan well in advance for this review and approval process, as rejection of a Submittal will require time for revision, re-submittal and review and no additional Contract time will be granted for this re-work.

## **SECTION 0106 - MINIMUM SAFETY REQUIREMENTS DURING CONSTRUCTION**

At a minimum, the Contractor must provide at his own cost safety equipment for his employees and ensure that the equipment is used appropriately. He shall require and ensure that his sub-contractors also comply with the requirements of this section. Minimum safety equipment includes the following:

- Hard hats must be provided for and worn by all employees and site visitors when in the vicinity of overhead, falling or other related hazards.
- Close-toed shoes must be worn by all construction workers when the potential for injury to feet or toes is present. This includes but may not be limited to workers in trenches, where tools or materials can fall from above them, workers operating any equipment, workers carrying materials or supplies at the job site.
- Eye protection must be worn during all cutting, grinding and welding processes or any construction process where the potential for air-borne particulates or flash from a welding operation could injure a worker's eyes.
- Hearing protection must be worn by workers engaged in very loud activities such as metal grinding or cutting, operating an electric saw, or operating loud machinery.

The Contractor shall take all necessary measures to protect the work and prevent accidents during the construction. He shall provide and maintain sufficient night-lights, barricades, guards, temporary sidewalks, temporary bridges, danger signals, watchmen and necessary alliances and safeguards to properly protect life and property. He shall also protect all excavations, equipment and materials so that the public are not be endangered.

The Supervisor or his representative, and any representative of the Contracting Authority has the right and ability to stop work at any stage and any element should that person believe that these minimum safety requirements are not being met or that the health and safety of the workers, public or other people present at the site is at risk of injury. The Contractor shall have no recourse for time extension should the work be delayed due to a safety-related stoppage. The cost for providing adequate safety equipment and supplies is included in the Contractor's cost for Mobilization, Item 01-A1.as neatly as practicable to its original conditions.

No separate payment shall be made to the Contractor for complying with the stipulations of this Sub-Clause.

## **SECTION 0107 - REPORTS, MEETINGS AND DATA OF THE WORKS**

### **1.1 Monthly Report**

The Contractor shall furnish to the Supervisor, at the Contractor's own cost, at regular monthly intervals and in a form and number of copies determined by the Supervisor, with the following information:

- a. Brief summary of the physical progress for the preceding month and estimated progress for the report month;
- b. updated completion schedules based on the approved Construction Programme, see Section 1.06 of these Specifications;
- c. inventory of construction equipment and materials on which an advance was made by the

- Contracting Authority as provided in the Conditions of Contract;
- d. any report which may be specifically requested by the Contracting Authority and/or the Supervisor.

## **1.2 Site/Work Meetings**

The Contractor shall attend all the Site/Work Meetings called by the Supervisor. At a minimum, during the construction season when work is in progress, the Contractor's on-site manager shall meet with the Supervisor weekly to review progress and any problems. The Contractor must be prepared to review and discuss his current Construction Schedule and his plans for the coming 4 weeks, including construction activities, material deliveries, and submittals pending and in development, job site safety and access issues, and any other topics the Supervisor deems important to discuss.

No separate payment shall be made to the Contractor for complying with the stipulations of this Sub-Clause.

## **SECTION 0108 - DISRUPTION OF LOCAL COMMUNITIES AND PROTECTION OF REAL ESTATE**

The Contractor shall take all measures necessary to avoid nuisance and disruption to local communities and ensure that the Contractor's operations do not cause flooding or pollution hazards. The Contractor shall control the movement of his crews and equipment on right-of-way including access routes approved by the Supervisor so as to minimise damage to crops, pasture or woodland and property and shall endeavour to avoid marring the lands. Ruts and scars shall be obliterated and damage to land shall be corrected and the land shall be restored

## **SECTION 0109 - TEMPORARY FENCING**

If and where required, the Contractor shall erect and maintain suitable and approved temporary fencing to enclose such areas of the works and areas of land occupied by the Contractor within the Site as may be necessary to safeguard the public or prevent theft or vandalism.

Fences crossed by the Works and forming boundaries of plots outside the area occupied by the Works shall not be cut through or destroyed for more than the distance necessary to permit the erection of new fencing etc., and the Contractor shall make the ends of the cut fences reasonably secure.

The Contractor shall regularly inspect all such fencing, and any defects which may occur, shall be made good without delay. Temporary Fencing shall remain in position until the Works are completed and the Site cleared of all plant, materials and/or other waste matter.

No separate payment shall be made to the Contractor for complying with the provisions of this Sub-Clause.

## **SECTION 0120 - CONTRACTOR'S CAMP**

### **1. SCOPE**

The work to be done under this item consists of construction, erection, installation and maintenance of the Contractor's Project Site Offices or main camp and the Contractor's sub-camps or temporary camps, if any, and shall include all offices, shops, warehouses, and other operational

buildings; all housing and related facilities including accommodations for the Contractor's personnel.

## **2. GENERAL**

The location of the Contractor's camps, including all buildings, utilities and facilities therefore, and of the camps or establishments of all persons/parties in the vicinity operating or associated with the Contractor shall be subject to approval of the Supervisor.

The work to be done under this item will terminate upon the actual Completion Date. However, if directed by the Supervisor or the Employer, the Contractor shall continue such work to the extent required by the Contractor's personnel during the period of maintenance. No compensation shall be paid for the continued operation and maintenance of the Contractor's Camps during the period of maintenance.

Upon completion of the Works, or at such time within the period of maintenance as directed by the Supervisor, the Contractor shall remove all buildings utilities and other facilities from the Site and restore all camp areas to a neat and clean condition.

Contractor shall protect the environmental interests and EU regulations at camp and works sites during execution of the contractual work.

## **3. CODES AND STANDARD**

The construction, operation and maintenance of all camps of the Contractor shall comply with all applicable provisions of current American Labour Camp Rules.

## **4. MAINTENANCE**

The Contractor shall furnish, make arrangements for, and carry out proper and adequate maintenance of the Contractor's Camp areas at such camp to provide a neat, well-kept camp in all respects with pleasant and healthy surroundings and conditions for all occupants of their camp.

Adequately equipped and properly staffed portable first aid stations or dispensaries shall be provided by the Contractor at camps and other strategic locations to administer first aid treatment at any time required and free of charge to all persons on the Site, including employees of the Supervisor and the Employer.

## **5. MEASUREMENT AND PAYMENT**

No payment shall be made for the works involved within the scope of this section of specifications unless otherwise specifically stated in the Bill of Quantities or herein. The cost thereof shall be deemed to have been included in the quoted unit rate of other items of the Bill of Quantities.

## **SECTION 0150 - CLEARING AND GRUBBING**

### **1. SCOPE**

The clearing and grubbing shall consist of clearing the designated area of all trees, down timber, snags, bush, other vegetation, rubbish and all other objectionable material, and shall include grubbing stumps, roots, and matted roots, and disposal of all spoil material resulting from the clearing and grubbing. It shall also include the removal and disposal of structures that protrude, encroach upon, or otherwise obstruct the work, except when otherwise provided for on the plans or directed by the Supervisor to be saved. The scope of this section of specifications is covered with detailed specifications laid down herein.

### **2. LIMIT OF AREA**

#### *2.1 Location of Works*

The Supervisor will define the limit of areas where clearing and grubbing is to be done. Normally it will include all land within premises of the site and all other construction area including ditches, detours, minor road crossings and other areas shown on the plans or as specified or as directed by the Supervisor. The Supervisor will designate the fences, structures and debris and trees and bushes to be cleared where grubbing is not required. It shall not include clearing and grubbing of borrow or other pit areas from which material is secured. It shall include the levelling or removal of all bunds or mounds within the limits/ boundary of site unless otherwise directed by the Supervisor.

#### *2.2 Grubbing and Cutting*

All roots and stumps within the limits of the site shall be grubbed and excavated unless otherwise specified or approved by the Supervisor.

#### *2.3 Disposal*

All wood and bushes shall be burned or otherwise disposed off within fifteen (15) days after cutting or felling unless otherwise approved. No tree trunks, stumps or other debris shall be left within Site unless approved in writing by the Supervisor. The location of disposal areas shall be within or outside the limits of the project or as approved in writing by the Supervisor and shall be acquired by the Contractor at his own expense. Any useable material shall remain the property of the Employer.

#### *2.4 Protection and Restoration*

The Contractor shall prevent all damage to pipes, conduits, wires, cables or structures above or below ground. No land monuments, property markers, or official datum points shall be damaged or removed until the Supervisor has witnessed or otherwise referred their location and approved their removal. The Contractor shall so control his operations as to prevent damage to trees and shrubs, which are to be preserved. Protection may include fences and boards lashed to trees to prevent damage from machine operations. The existing covered or open benchmarks should be relocated as directed by the Supervisor. In the event that anything specified herein to be saved and protected is damaged by the Contractor; such damages shall immediately be repaired or replaced by the Contractor at his own cost to the satisfaction of the Supervisor. All areas cleared and grubbed must be approved by the Supervisor or Supervisor's Representative before the start of cleaning operations.

### **3. PAYMENT OF WORK**

No payment shall be made for the Works involved within the scope of this Section of Specifications unless otherwise specifically stated in the Bills of Quantities or herein. The cost thereof shall be deemed to have been included in the quoted unit rate of other items of the Bills of Quantities.

## **SECTION – 0500, LANDSCAPING**

## 01 SCOPE

The Work under this section of specifications consists of providing all material, plant, labor and equipment for landscape development in the school area consisting of proper planting of trees and development of lawn/ grass complete in accordance with this section of specification and applicable drawings and/or as directed by the Engineer.

## 02 MATERIALS AND PREPARATION

### 2.1 Bed Preparation:

All debris, gravelly and salinity affected materials from the entire area shall be removed from the soil up to a depth of at least 300 mm and it shall be filled with a 300mm thick salt free layer of selected evenly over the sweet earth in a 100 mm thick layer and worked with a spade or plough into the soil up to a depth of about 150 mm for proper blending. For supplying ample nutrition to the newly establishing lawn, the proportions of different fertilizers may be added as per manufacturer recommendations and spread uniformly by hand on the ground along with the organic manure in the soil.

The ground shall be leveled so that water distribution is even and the water does not stand at any spot.

### 2.2 Seeding:

Scrapped turf grass shall be used for lawns and overgrown and unhealthy turf shall be avoided for seeding.

The turf shall be scrapped 25-50 mm below the ground to include root in the scrapping. For planting, about 25-50 sq.mm piece of turf shall be placed in the soil with the help of dibble and pressed a little. Planting shall preferably be done in the morning or evening hours, when it is relatively cooler.

### 2.3 Watering:

The newly planted lawns shall be watered heavily once or twice a day for about a week or a fortnight. Later, a heavy irrigation once or twice a week shall be provided.

### 2.4 Mowing:

New grass shall be mowed with a roller mower when it reaches a height of about 50mm.

### 2.5 Planting of Trees:

Pits, approximately of a size 1m x 1m shall be dug in advance and protected from rain. To allow new roots to penetrate and help trees re-establish quickly, bottoms of pits shall be broken up to a minimum depth of 250 mm and if any soil on sides of pits is "polished" this shall also be forked to loosen it.

The pits shall be backfilled with sweet earth of approved quality and well-balanced fertilizer.

Tree plants shall be true to type, of reasonable size and shape, free from any pest, diseases or physical defects. Plants shall be pot in at the same depth as when growing in the nursery. This can be determined by the soil marks on necks of plants. After planting, the soil shall be formed lightly breaking up surfaces to allow water and air to penetrate. Watering shall be done as per requirement

of each plant and as per directions of the Engineer.

Plant guards formed of specified size plain bars clad with diamond shaped G.I wire mesh as per approved design shall be furnished and installed for protection of each tree plant.

### 3. **Measurement & Payment:**

3.1 **General:** Except otherwise specified herein or elsewhere in the Contract Documents, no measurement and payment will be made for the under mentioned specified works related to the relevant items of the Bill of Quantities. The cost thereof shall be deemed to have been included in the quoted unit rate of the respective item (s) of the Bill of Quantities.

3.1.1 Excavation of trenches to required depth and width of trees, shrubs and lawn grass for plantation.

3.1.2 Scarifying soil at the bottom of the trench and adding and mixing equal amount of prepared soil.

3.1.3 Prepared soil mix, puddle and setting plants, shrubs, vines and ground cover.

3.1.4 Berm firmly compacted

3.1.5 Guying and stacking material.

3.1.6 Sweet earth, manure and seed for turf lawn grass and trees.

3.1.7 Restoration, cleanup and maintenance during contract period.

3.1.8 Bed preparation, seeding mowing & watering the plants, shrubs, lawn grasses.

### 3.2 **Landscaping**

3.2.1 **Measurement:** Measurement of acceptably completed works landscaping including supply and laying of fertilizer, sweet earth and grass will be made on the basis of actual area in square meter of lawn provided, planted and laid in position as shown on the Drawings or as directed by the Engineer.

3.2.2 **Payment:** Payment will be made for acceptable measured quantity of landscaping on the basis of unit rate per square meter quoted in the Bill of Quantities and shall constitute full compensation for all the works related to the item.

### 3.3 **Tree plantation**

3.3.1 **Measurement & Payment:** Measurement & payment of acceptably completed work of tree plantation including supply and laying of fertilizer, sweet earth will be made on the basis of actual numbers of trees planted in position as shown on the Drawings or as directed by the Engineer.

## **SECTION 1100 - EARTHWORKS**

### 1. **SCOPE OF WORK**

The work under this section of the specifications consists of furnishing all plant, labour, equipment, appliances and materials and in performing all operations in connection with earthworks of all underground services and structural units, stock piling of suitable excavated material, disposal of



unsuitable and surplus excavated material in accordance with this section of specifications, the applicable drawings and subject to terms and conditions of the Contract.

## **2. GENERAL**

2.1 The Contractor shall be deemed to have made local and independent inquiries as to, and shall take the whole risk of, the nature of the ground subsoil or material to be excavated or penetrated and the Contractor shall not be entitled to receive an extra or additional payment nor to be relieved from any of his obligations by reasons of the nature of such ground subsoil or material.

2.2 All excavations, cut and fills shall be constructed to the lines, levels and gradients specified with any necessary allowance for consolidation, settlement and drainage so that at the end of the Period of Maintenance the ground shall be at the required lines, levels and gradients. During the course of the Contract and during the Period of Maintenance any damage or defects in cuts and fills, in structures and other works, caused by slips, falls of wash-ins or any other ground movement due to the Contractor's negligence shall be made good by the contractor at his own cost.

## **3. SITE PREPARATION**

3.1 The Contractor shall set out the works and shall be responsible for true and perfect setting out of the same and for correctness of the positions, levels, dimensions and alignments of all parts thereof. If at any time any error in this respect shall appear during the progress of the works, the Contractor shall at his own expense rectify such error, to the satisfaction of the Supervisor.

3.2 The Contractor shall construct and maintain accurate bench marks so that the Lines and Levels can be easily checked by the Supervisor.

3.3 The Contractor shall perform a joint survey with the Supervisor's Representative, of the area where earth work is required, plot the ground levels on the drawings and obtain approval from the Supervisor before starting the earth work and shall supply a copy to the Employer duly checked, signed and authenticated by the Supervisor before start of work.

## **4. EXCAVATIONS**

4.1 Excavation shall include the removal of all material of every name and nature at the site. If, in the sole opinion of the Supervisor, the site contains soils that are not appropriate for use as sub-base, the poor quality material shall be removed and not re-used as fill.

Unacceptable soils shall be excavated to a depth below the structure to be built. Unacceptable soils shall be removed from the site and disposed of at a location approved by the Supervisor. Remove unacceptable soils to a total depth below ground surface of 120 cm. Backfill the excavation to a depth of 90cm with select soils (approved by Supervisor), and compact to 95%. Place 10 cm of PCC as a blinding layer. Construction of the foundation as designed may be completed from this point.

It is expected that rock and other hard man made material will be encountered during excavation. The rate of excavation shall include the removal of all sub-surface material of every name and nature and no classification of sub-surface material shall be made nor shall any additional payment be made.

4.2 The major portion of excavations shall be carried out by mechanical excavators and excavated materials either disposed or stockpiled on site as directed by the Supervisor. Note that some on-site soils may not be acceptable for backfilling. See specifications below for Fill soils. Unless otherwise specified by the Supervisor, levelling, trimming and

finishing to the required levels and dimensions shall be done manually. The material suitable for fill and backfill if approved by the Supervisor shall be stockpiled within the limits of whole of the Site as directed by the Supervisor.

Excavated material unsuitable for use as fill and backfill shall be disposed of by the Contractor at locations approved by the Supervisor within specified free haulage limit.

- 4.3 The Contractor shall give reasonable notice that he intends to commence any excavation and he shall submit to the Supervisor full details of his proposals. The Supervisor's approval shall not relieve the Contractor of his responsibility with respect to such work.
- 4.4 The Contractor shall preserve the completed excavation from damage due to slips and earth movements, ingress of water from any source whatsoever and deterioration by exposure to the sun and the effects of the weather.

All excavations shall be kept free of water and shall be maintained dry to the satisfaction of the Supervisor. Prevent surface water and sub-surface water and sub-surface ground water from flowing into the excavation and flooding the project site and surroundings.

Do not allow water to accumulate in excavations, remove water from excavations to prevent softening of foundation bottoms, under cutting footings and soil changes determined to the stability of sub-grades and foundations. Provide and discharge lines necessary to convey the water away from the excavations convey water removed from excavation and rain water to outside the limits in manner that no damages is caused to the surrounding services properties.

- 4.5 Excavation for pits, cable trenches, equipment-foundations and other structures shall be taken out to the levels and dimensions shown on Drawings or such other levels and dimensions as the Supervisor may direct.
- 4.6 Excavation shall extend to adequate distance from walls and footings to allow for placing and removal of forms, installations of services and for inspection, except where the concrete for walls and footings is authorized to be deposited directly against excavated surfaces. Undercutting will not be permitted. The additional excavation for placing and removal of forms, installation of services, for inspection and generally for working area on slopes for stability shall not be measured for payment and shall be deemed to be included in the rates for excavation as measured net.
- 4.7 All excavations for foundations shall be taken to 6 inch above the final excavation elevations shown on the drawings and the last 6-inch shall be trimmed carefully to a smooth and level surface. Immediately after trimming to the final elevation, a layer of blinding concrete shall be placed to the thickness shown on the drawings. All excavations for foundations which have been trimmed and disturbed shall be compacted and covered by lean concrete by the end of the day.
- 4.8 No excavation shall be refilled nor any permanent work commenced until the foundation has been inspected by the Supervisor and his permission to proceed is given.
- 4.9 If excavation for sub-structures is carried below the required level, as shown on the Drawings or as directed by the Supervisor, the surplus depth shall be filled in with concrete of same grade as of blinding concrete at the sole cost of the Contractor.

- 4.10 All excavation shall be performed in the dry. The placing of blinding concrete, placing of reinforcement and casting of the permanent works in the excavation shall be carried out in the dry.
- 4.11 Shoring, where required during excavation, shall be installed to protect workmen and the bank, adjacent paving, structures and utilities. The term shoring shall also be deemed to cover whatever methods the Contractor elects to adopt, with prior approval of the Supervisor, for upholding the sides of excavation and also for planking and strutting to excavation against the side of roadways and adjoining properties in existing hardcore of any other material. The Contractor will be held responsible for upholding the sides of all excavations and no claim for additional excavation, concrete or other material will be considered in this respect.
- 4.12 Existing utility lines that are shown on the drawings or the locations of which are made known to the Contractor prior to excavation and that are to be retained, as well as utility lines constructed during excavation and backfilling, and if damaged, shall be repaired by the Contractor at his own expense. Any existing utility lines which are not known to the Contractor in sufficient time to avoid damage, if inadvertently damaged during excavation, shall be repaired by the Contractor and adjustment in payment will be made as approved by the Supervisor. When utility lines which are to be removed, are encountered within the area of operations the Contractor shall notify the Supervisor in ample time for the necessary measures to be taken to prevent interruption of the service.
- 4.13 Where applicable the excavation work shall include the excavation in above water table and excavation below water table. The Contractor shall provide all plant, equipment, pumps, sheeting, and well points as required to keep the water table 3.0 feet below the deepest foundation as shown on the drawings till the completion of foundation works.
- 4.14 Before starting the excavation for pipelines, the Contractor shall ensure the correct alignment of the pipeline on the ground the depth and width of excavation of the trench, all in accordance with the Drawings and instructions of the Supervisor. The Contractor shall make profile with cement concrete pillars.

Excavation shall be carried out true to lines, levels, grades and widths as shown on the drawings or as directed by the Supervisor ensuring proper lying of the pipe line, the bedding fill, construction of chambers for appurtenances and any other structures. The trench bottom shall be graded to provide even and substantial bearing over the specified bedding and of the structure.

Without the written permission of the Supervisor, not more than 600 feet of the trench shall be opened in advance of the completed pipeline.

- 4.15 The Supervisor may require the Contractor to excavate below the elevations shown on the drawings or he may order him to stop above the elevations shown depending upon the suitable foundation material encountered.
- 4.16 If for any reason, the levels, grades or profiles of the excavations are changed adversely by the Contractor, the Contractor shall at his own cost, be liable to bring the excavations to the required levels and profiles as shown on the drawings or as directed by the Supervisor.

## **5. EXCAVATION TOLERANCES**

Excavation shall be performed within the tolerances for excavation limits indicated on the drawings. Where no tolerance limits are indicated, excavation shall be performed to tolerances established by the Supervisor as acceptable for the design and type of work involved.

## 6. **FILL AND BACKFILL**

6.1 The backfilling shall include filling under the floors, around the foundation trenches, pipes, conduits, ducts and channels.

The backfilling shall include loading, unloading, transporting, placing, stacking, spreading of earth, watering, rolling, ramming and compacting, etc., complete as specified herein.

6.2 The excavated material if found suitable shall be stockpiled within the free haulage limit of the Project Boundary. This material shall be used for filling/back-filling if approved by the Supervisor and shall be transported by the Contractor anywhere required for the purpose of filling/back-filling work in this Contract.

6.3 The Contractor shall provide the approved quality of backfill and fill material required to complete the fill and backfilling work from the places as designated by the Supervisor.

Deep filling shall be predominantly granular material and free from slurry mud, organic or other unsuitable matter and capable of compaction by ordinary means.

### 6.4 Select and Common Fill

Soils used to backfill excavations shall consist of mineral soil substantially free from organic materials, loam, wood, trash and other objectionable materials which may be compressible or which cannot be properly compacted. Fill shall not contain stones larger than 50 mm in largest dimension and shall be well graded. Fill soils shall not contain stone blocks, broken concrete, masonry rubble or other similar materials. It shall have physical properties such that it can be readily spread and compacted during filling.

Fill soils shall be placed in maximum 100-mm lifts and compacted to 95% of the maximum dry density, or as otherwise shown in the Drawings or directed in writing by the Supervisor.

Fill soils shall be recovered by the Contractor from the excavations made during the course of the excavation work or imported from an approved off-site source and used where Fill is specified to be used in the work.

6.5 Filling around pipes and cables shall be carefully placed with fine material to cover the pipe or cable completely before the normal fill is placed.

6.6 Backfilling of trenches/foundations shall be carried out only after the pipe line/structural works within the excavations have been inspected, tested and approved by the Supervisor.

6.7 Fill shall not be placed against foundation walls prior to approval by the Supervisor. Fill shall be brought up evenly on each side of the walls as far as practicable. Heavy equipment for spreading and compacting the fill shall not be operated closer to the wall than a distance equal to the height of the fill above the top of footing.

6.8 Before the start of fill and backfill, the Contractor shall satisfy himself as to the levels and slopes of the fills and backfill shown on the Drawings, the requirements of compaction, the

possibility of settlement & all other particulars whatsoever in connection with the filling works.

- 6.9 All filled areas shall be left neat, smooth and well compacted, the top surface consisting of the normal site surface soil, unless otherwise directed.

## **7. TOLERANCES**

The stabilization of compacted backfill/fill surface shall be smooth and even and shall not vary more than 3/8 inch in 10 feet from true profile and shall not be more than 1/2 inch from true elevation.

## **8. DISPOSAL OF SURPLUS EXCAVATED MATERIAL**

8.1 The rejected unsuitable material and surplus excavated material shall be disposed off anywhere within 10-kilometer lead measured along the most direct route from the project boundary, as directed by the Supervisor. No compensation of any lead/lift is admissible and rates quoted shall be deemed to include the same.

8.2 The disposal of surplus/unsuitable excavated material shall include loading, unloading, transporting, stacking, spreading and levelling as directed by the Supervisor.

## **9. MEASUREMENT AND PAYMENT**

### **9.1 General**

Except otherwise specified herein or elsewhere in the Contract Documents, no measurement and payment will be made for the under mentioned works related to the relevant BOQ items. The cost thereof shall be deemed to have been included in the quoted unit rate of the respective items of the Bill of Quantities.

9.1.1 Timber shoring, planking, strutting and providing slope for upholding the sides of excavations.

9.1.2 Any fill with approved material necessitated by over excavation due to fault or convenience of the Contractor except under structural members.

9.1.3 Stockpiling the excavated material at approved location within free haulage limit of the Project Boundary and transporting back suitable material to places requiring fill or backfill.

9.1.4 Specified foundation bed preparation.

9.1.5 Excavation involved in providing adequate working space around sides of foundation and service line trenches.

9.1.6 Providing approved quality fill/backfill material obtained from excavated material as designated by the Supervisor.

9.1.7 Rolling, levelling, watering & compacting the fill and backfill to required compaction.

9.1.8 All laboratory and field tests stipulated in these specifications.

9.1.9 Disposal of rejected surplus and unsuitable excavated material anywhere within 10-kilometer lead measured along the most direct route from the project boundary, as directed by the Supervisor. No compensation of any lead/lift is admissible and rates quoted shall be deemed to include the same.

9.1.10 De-watering to keep the foundations dries during construction.

## 9.2 Excavation

### 9.2.1 Measurement

Quantities of excavation shall be calculated/measured from the pre-work levels of levelled and graded ground taken jointly by the Contractor and the Supervisor before commencement of the work.

The quantities set out for excavation and its subsequent disposal shall be deemed to be the bulk quantity before excavating and no allowance shall be made for any subsequent variations in bulk or for any extra excavation.

Unless otherwise shown on the Drawings quantities of excavation shall be measured of acceptably completed works on the basis of vertical excavations required in accordance with lines of concrete.

Quantities of excavation for laying service line trenches shall be measured for payment on the basis of vertical excavation faces for the specified width for the trench as shown on the drawings.

Measurement for acceptably completed excavation works shall be made on the basis of number of cubic meter of material excavated for foundation and service trenches as shown on the Drawings or as directed by the Supervisor.

**9.2.2 Payment:** Payment will be made for acceptably measured quantity of excavation on the basis of unit rate per cubic meter quoted in the Bills of Quantities and shall constitute full compensation for all the works related to the item, including but not limiting to back filling.

## 9.3 Backfill/Fills

**9.3.1 Measurement:** Measurement for acceptably completed backfill/fill works will be made on the basis of number of cubic meter of compacted backfill/fill in position in accordance with the lines, levels and grade as shown on Drawings or as directed by the Supervisor.

**9.3.2 Payment:** Payment will be made for acceptably measured quantity of backfill/fill on the basis of unit rate per cubic meter quoted in the Bills of Quantities and shall constitute full compensation for all the works related to the item.

## **SECTION 1300 - STONE SOLING and STONE MASONRY**

### 1. SCOPE

The work under this section of specifications consists of furnishing all plant, labour, equipment, appliances, materials and performance of all operations required in connection with the construction of stone soling in strict accordance with the specifications and Drawings and/or as directed by the Supervisor. The scope of this section of specification is covered with detailed specifications as laid down herein.

The terms "Stone Soling" and "Stone Masonry" refer to the rock sub-base material that underlies the building columns and beams.

### 2. MATERIAL

Material shall be of approved quality it shall be comprise strong hard durable stone of the approved size free from impurities, quarry sap, dust, dirt and solubility characteristics. The stone shall be obtained from approved quarries and shall be sound, free from laminations and weak cleavages.

### 3. **QUALITY CONTROL**

The quality of material used in stone soling shall conform to the following.

- Maximum Los Angeles Abrasion value 30% determined as per ASTM C- 535-81.
- Soundness 5 cycles with sodium sulphate determined as per ASTM C-88-8.
- Specific Gravity shall be not less than 2.5 determined as per ASTM C-127- 84.
- Water Absorption shall not be more than 1.5%

### 4. **CONSTRUCTION**

#### 4.1 **Preparation of Sub-grade**

Sub-grade shall be formed of suitable materials free of clods, sod, roots, stumps, brush or other objectionable material.

Sub-grade material shall be placed in successive layers not exceeding 6 inch in thickness and each layer shall be thoroughly compacted at optimum moisture content.

The sub-grade shall be compacted at optimum moisture content and loose pockets, if any, cut-out and refilled with selected materials in layers not more than 150mm thick and formed to levels and grades shown on the drawings.

Compaction shall be done by approved methods consistent with the soil/material to be compacted.

The maximum dry weight density of the sub-grade shall not be less than 95% of Modified AASHTO requirements.

#### 4.2 **Stone Ballast Soling**

The Stone Ballast shall be well graded and broken hard of 2" mesh obtained from an approved quarry. The soling stone shall be 100mm in size from an approved quarry,

The stone shall be laid and packed to even grades and well rolled using vibratory roller/plate compactor to a consolidated thickness in lifts not less than 6 inches.

The whole of the surface of the compacted stone soling layer will be blinded with an approved gritty material/ stone dust or fine sand material. After the interstices have been filled with smaller size crushed stone, so as to effectively fill in the voids and crevices, soling area may be watered, if necessary and again thoroughly rolled with the same roller to produce a smooth and even surface free from irregularities, true to line and level.

Care is to be taken to avoid any damage to existing structures, mains or pipes while rolling operation is in progress. In places inaccessible for a roller, compaction shall be done by hand tampers weighing not less than 20 lb. or power reamers as directed by the Supervisor.

### 5. **MEASUREMENT AND PAYMENT**

#### 5.1 **General**

The cost of the following items must be included in the unit rate for Stone Soling and Stone Masonry quoted in the Bill of Quantities. No additional payment for these works shall be considered.

- Any losses of material, which may result from shrinkage, compaction, waste, overflow erosion, etc.
- Sub-grade preparation.
- Murom or any other approved gritty material/ stone dust used as a blinding material.
- Ballast material of approved quality.
- Compaction of sub-grade and stone.

## 5.2 Stone Soling

### 5.2.1 **Measurement:**

Measurement of acceptably completed works of stone soling will be made on the basis of number of square meter of compacted soling in position as shown on the Drawings or as directed by the Supervisor.

### 5.2.2 **Payment:**

Payment will be made for acceptable measured quantity of compacted stone soling on the basis of unit rate per square meter quoted in the Bill of Quantities and shall constitute full compensation for all the works related to the item.



## **SECTION 2100 - FORMWORK**

### **1. SCOPE**

The work under this section of the Specifications consists of furnishing all plant, labour, equipment, appliances and materials and in performing all operations in any floor and roof and floor and at any height in connection with the supply and installation of formwork for the purpose of shuttering in concreting work, complete in strict accordance with this section of the specifications and the applicable drawings and subject to the terms and conditions of the Contract. The works include all formwork required at any floor and at any height required for the completion of the work as per drawings/specifications.

### **2. GENERAL**

It shall be the responsibility of the Contractor to perform the work by engaging well-trained & experienced staff or by the sub-contractor who shall have enough number of well-trained and experienced staff to coordinate his activities with the other operations. However, the Contractor shall be responsible for the quality of work performed by the sub-contractor as per the requirements of these specifications.

### **3. MATERIALS**

The Contractor shall use the following formwork materials for different purposes as stated below:

#### **3.1 Timber**

Form framing, sheathing and shoring.

#### **3.2 Plywood**

Form sheathing and panels.

#### **3.3 Steel**

- Heavy forms and false work
- Column and joint forms
- Permanent forms
- Welding of permanent forms

#### **3.4 Form Ties Anchors and Hangers**

For securing formwork against placing loads and pressures.

#### **3.5 Coatings**

To facilitate form removal.

#### **3.6 Steel Joists**

For formwork support.

#### **3.7 Steel frame shoring**

For formwork support.

### **4. DELIVERY AND STORAGE**

#### **4.1 Delivery**

Formwork materials shall be delivered and stored so that damage is prevented.

#### **4.2 Storage**

Formwork should be stored, after cleaning and preparing for re-use if used before, in such a manner that access to all different materials is available.

Material which can be affected by weathering shall be stored in appropriate building or under covers and shade.

## 5. WORKMANSHIP

- 5.1 Forms shall have sufficient strength to withstand the pressure resulting from placement and vibration of the concrete and shall have sufficient rigidity to maintain specified tolerances.

The Supervisor has the authority to refuse any formwork in any part of the building that does not conform to details of special forms shown on the Drawings. The Supervisor shall refuse any concreting which will not be perfect or may not conform to the approved model.

- 5.2 Earth cuts shall not be used as forms for vertical surfaces of reinforced concrete work unless required as such or permitted by the Supervisor.
- 5.3 Mud centring shall not be permitted without the prior approval of the Supervisor.
- 5.4 Formwork shall be of wrought timber, steel, plywood, proprietary building boards and such special materials, as may be shown on the drawings or approved by the Supervisor, which give the required finish to the surface of concrete. Wooden formwork shall be free from loose knots and shall be well seasoned.

The responsibility of the safe design of the formwork shall be entirely that of the Contractor.

No wooden props, bamboo, bellies, etc., shall be used as supports to beams or roofs and floors. Only steel pipe scaffoldings (tubular) to be used for all works.

Only wooden planks of approved quality and thickness of 2 inches minimum on the sides of beams shall be allowed.

All the erected formwork shall be inspected and approved in all respects by the Supervisor or his representative prior to concreting.

Where concrete will be exposed to view, special care shall be taken in the selection of the form material and the construction of the forms, to the end that the concrete will be smooth, uniform in texture, true in line and face and free from honey-combing and other projections. All sides and joints on the forms shall be flush (without lapping) and inconspicuous, wood used for such work shall be thoroughly cleaned before each reuse and shall be free from cracks, splinters, nails, or other defects effecting the appearance of the concrete.

- 5.5 The formwork shall conform to the shape, lines and dimensions as shown on the plans and be so constructed as to remain sufficiently rigid during the placing and compacting of the concrete, and shall be sufficiently tight to prevent loss of liquid from the concrete.

The design and Supervisory of the formwork, as well as its construction, shall be the responsibility of the Contractor. Where necessary, to maintain the specified tolerances, the formwork shall be cambered to compensate for anticipated deflections in the formwork due to the weight and pressure of the fresh concrete and due to construction loads.

The Contractor shall establish and maintain in an undisturbed conditioned until final completion and acceptance of the project, sufficient control points and benchmarks to be used as references for checking upon tolerances.

Forms for architectural concrete shall be designed to produce the required finish or finishes. Deflection of facing materials between studs as well as deflection of studs and walers shall be limited to 0.0025 times the span or as otherwise specified.

- 5.6 Forms shall be designed to permit easy removal. Prying against the face of the concrete shall not be allowed. Only wooden wedges shall be used.
- 5.7 Where natural plywood -formfinish, -grout-cleanedfinish, -smooth-rubbed finish, -scrubbedfinish or -sand-floatedfinish is required-, forms shall be smooth (faced with plywood, liner sheets, or prefabricated panels) and true to line, in order that the surfaces produced will require little dressing to arrive at true surfaces. Where any -ascast finish is required, no dressing shall be permitted- in the finishing operation.
- 5.8 Where as cast surfaces, including natural plywood- -form-finish are specified, the panels of material against which concrete is cast shall be orderly in arrangement, with joints between panels planned in approved relation to openings, building corners, and other architectural features.
- 5.9 Where panels for as cast surfaces are separated by recessed or otherwise emphasized joints, the structural design of the forms shall provide for locating- form ties, where possible, within the joints so that patches of tie holes will not fall within the panel areas.
- 5.10 Forms shall not be re-used if there is any evidence of surface wear and tear or defect, which would impair the quality of the surface finish. Forms shall be thoroughly cleaned and properly coated with form oil before re-use.
- 5.11 The formwork shall be designed so that the soffits of slabs and sides of beams, columns and walls may be removed first, leaving the forms to the soffits of beams and their supports in position.
- 5.12 Forms shall be sufficiently tight to prevent loss of mortar from the concrete. Unless otherwise specified in the Contract Documents chamfer strips shall be placed in the corners of forms to produce bevelled edges on permanently exposed surfaces. Interior corners on such surfaces and the edges of formed joints will not require bevelling unless required by the Contract Documents.
- 5.13 Positive means such as wedges or jacks for accurate adjustment and for proper removal of shores and struts shall be provided and all settlement shall be monitored during concrete placing operation. Forms shall be securely braced against lateral deflections.
- 5.14 Where concreting of thin members is required to be carried out within formwork of considerable depth, temporary openings in the sides of the formwork shall be provided where necessary to facilitate the placing and consolidation of concrete. Small temporary openings shall also be provided at the bottom of the formwork for columns, walls and deep beams to permit the cleaning out of debris and observation immediately before concrete is deposited.
- 5.15 Form ties shall be constructed so that the ends or end fasteners can be removed without causing appreciable spalling at the faces of the concrete. After the ends or end fasteners of form ties have been removed, the embedded portion of the ties shall terminate not less than 2 diameter or twice the minimum dimension of the tie from the formed faces of concrete to be permanently exposed to view except that in no case shall this distance be less than 3/4 inch. When the formed face of the concrete is not to be permanently exposed

to view, form ties may be cut off flush with the formed surfaces. Precaution shall be taken not to rotate form ties.

Through bolts may be permitted provided that they are greased to allow for easy withdrawal and the holes subsequently made good. Through bolts are not to be used on water-retaining structures and basement walls.

- 5.16 At construction joints contact surface of the form sheathing for flush surfaces exposed to view shall overlap the hardened concrete in the previous placement by no less than 1 inch. The forms shall be held against the hardened concrete to prevent offsets or loss of mortar at the construction joint so as to maintain a true surface.
- 5.17 Wood forms for wall opening shall be constructed to facilitate loosening, if necessary to counteract swelling of the forms.
- 5.18 Wedges used for final adjustment of the forms prior to concrete placement shall be fastened in position after the final check.
- 5.19 Formwork shall be so anchored to shores or to other supporting surfaces or members that upward or lateral movement of any part of the formwork system during concrete placement will not occur.
- 5.20 Runways or planks for moving labour and equipment shall be provided with struts or legs and shall be supported directly on the formwork or upon the structural member without resting on the reinforcing steel.
- 5.21 All surfaces of forms and embedded materials shall be cleaned of any accumulated mortar or grout from previous concreting and of all other foreign material before placing fresh concrete.
- 5.22 Forms shall be sufficiently tight to prevent leakage of grout or cement paste. Board forms having joints opened by shrinkage of the wood shall be removed and replaced. Plywood and other wood surfaces not subject to shrinkage shall be sealed against absorption of moisture from the concrete by either:
  - (1) A field applied, approved form oil or sealer, or
  - (2) A factory applied non-absorptive liner.

When forms are coated to prevent bond with concrete, it shall be done prior to placing of the reinforcing steel. Excess coating material shall not be allowed to stand in puddles in the forms nor allowed to come in contact with the concrete against which fresh concrete will be placed. Care shall be taken that such approved composition is kept out of contact with the reinforcement. Where as-cast finishes are required, materials, which will impart a stain to the concrete shall not be applied to the form surfaces. Where the finished surface is required to be painted, the material applied to form surfaces shall be compatible with the type of paint to be used.

- 5.23 For reinforced concrete, in no circumstances shall forms be struck until the concrete attains 75% of ultimate strength.

The strength referred to shall be that of concrete using the same cement and aggregates, with the same proportions, and cured under conditions of temperature and moisture similar to those obtaining in the work. Where possible, the formwork should be left for longer time as it would assist the curing.

In normal circumstances (generally where temperatures are above 20° C and where ordinary cement is used, forms may be struck after expiry of the following periods.

SHORING TYPE	PERIOD FOLLOWING POUR
Walls, columns and vertical sides of beams	48 hours or as may be decided by the Supervisor
Side of slab (shores or props left under)	6 days.
Beams soffits (shores or props left under).	12 days
Removal of shores or props to slabs:	
1.    Spans up to 3.66 m	10 days
2.    Spans over 3.66 m	16 days
Removal of shores or props to beams	
1.    Spans up to 5.49 m	18 days
2.    Spans over 5.49 m	25 days

For rapid hardening cement 3/7 of the above period will be sufficient in all cases except vertical sides of slabs, beams and columns which should be retained for a minimum of 24 hours.

The number of shores or props, their sizes and disposition shall be such as to be able to safely carry the full dead load of the slab and beams, as the case may be.

Proper allowance shall be made for the decrease in rate of hardening of concrete in cold weather and the above minimum duration must be increased when the mean daily temperature is below 20° C.

- 5.24 When repair of surface defects or finishing is required at an early age, forms shall be removed as soon as the concrete has hardened sufficiently to resist damage from removal operations.
- 5.25 Top forms on sloping surfaces of concrete shall be removed as soon as the concrete has attained sufficient stiffness to prevent sagging. Any needed repairs or treatment required on such sloping surfaces shall be performed at once and be followed by the specified curing.
- 5.26 Wood forms for wall openings shall be loosened as soon as this can be accomplished without damage to the concrete.
- 5.27 All formwork shall be removed without such shock or vibration as would damage the reinforced concrete. Before the top plank and struts are removed, the concrete surface shall be exposed where necessary in order to ascertain that the concrete has sufficiently hardened. Proper precautions shall be taken to allow for the decrease in the rate of hardening that occurs with all cement in the cold weather.
- 5.28 When reshoring or repropping is permitted or required, the operations shall be planned in advance and shall be subject to approval. While reshoring is underway no live load shall be permitted on the new construction. In no case during reshoring shall concrete in beam, slab, columns or any other structural member be subjected to combined dead and construction loads in excess of the load permitted by the Supervisor for the developed concrete strength at the time of reshoring.

Reshores shall be placed as soon as practicable after stripping operations are complete but in no case later than the end of working day on which stripping occurs.

Reshores shall be tightened to carry their required loads without overstressing the construction. Reshores shall remain in place at least until tests representative of the concrete being supported have reached the strength specified in sub-clause 5.23 hereof.

- 5.29 Floors supporting props or shores under newly placed concrete shall have their original supporting props or shores left in place or shall be reshored. The reshoring system shall have a capacity sufficient to resist the anticipated loads and in all cases shall have a capacity equal to at least one half the capacity of the shoring system above. The reshores shall be located directly under a shore position above unless other locations are permitted.

The reshoring or re-propping shall extend over a sufficient number of storeys to distribute the weight of newly placed concrete, forms, and construction live loads in such a manner that the design superimposed loads of the floors supporting shores or props are not exceeded.

- 5.30 It is generally desirable to give forms for reinforced concrete an upward camber to ensure that the beams or slabs (specially cantilever slabs) do not have a sag when they have taken up their deflection, but this should not be done unless permitted by the Supervisor.

- 5.31 No loads, other than man and light plant required in connection with the actual work in hand, shall be allowed on suspended floors until 28 days after concreting where ordinary Portland Cement is used and 14 days when rapid hardening Portland Cement is used.

- 5.32 Prior to placing concrete, all forms shall be inspected and all debris and extraneous matter removed. The form oil or release agent shall not react with concrete to affect the strength nor shall it give any color.

## **6. MEASUREMENT AND PAYMENT**

No payment will be made for the works involved within the scope of this section of the specifications unless otherwise specifically stated in the Bills of Quantities or herein.

The cost thereof shall be deemed to have been included in the quoted unit rate of relevant items of the Bills of Quantities.

## **SECTION 2200 - REINFORCEMENT**

### **1. SCOPE**

The work under this section of specifications consists of supplying, cutting, fabricating, bending and placing steel reinforcement and Welded wire fabric in any floor and at any height in concrete structures or elsewhere as shown on the drawings or as directed by the Supervisor. The scope of this section of specification is covered with detailed specifications as laid down herein.

### **2. APPLICABLE STANDARDS**

Latest editions of the following Pakistan, British and ASTM Standards are relevant to these specifications wherever applicable.

#### ASTM Standard

A 82	Cold- Drawn steel wire for concrete reinforcement.
A 305	Minimum requirement for the deformations of deformed steel bars for concrete reinforcement.
A 615	Deformed billet steel bars for concrete reinforcement, Grade 60 and Grade 40.

In addition to the above, the latest editions of other Pakistan Standards, British standards, American Concrete Institute Standards, American Society for Testing and Materials Standards and other standards as may be specified by the Supervisor for Special Material and construction are also relevant.

### **3. MATERIAL AND SIZE OF BARS**

- 3.1 Reinforcement for concrete shall conform to the respective British, ASTM, or other Standards as specified in the Drawings and in the Contract Documents or as may be specified by the Supervisor.
- 3.2 Unless otherwise specified all steel bars for reinforcements of concrete shall conform to ASTM A615, Grade.
- 3.3 Reinforcement shall be obtained only from manufacturers approved by the Supervisor. Each consignment of reinforcement steel shall be accompanied by the manufacturer's certificate or shall refer to a previous certificate, if the consignment is from the same batch, showing that the reinforcement steel complies with the specified requirement. If such certificate is not made available or if the Supervisor considers that the manufacturer's tests are inadequate, samples shall be taken for acceptance test from different consignments as the Supervisor may direct and shall be tested at the contractor's cost. Should the result of such tests show that the sample does not meet with the specifications the whole consignment shall be rejected and removed from the site at the Contractor's cost.
- 3.5 Reinforcement shall be free from all loose or flaky rust and mill scale, or coating, including ice, and any other substance that would reduce or destroy the bond. Reduced section steel reinforcement shall not be used.

### **4. DELIVERY & STORAGE**

#### 4.1 Delivery

Steel reinforcement bars shall be kept in bundles firmly secured and tagged. Each bar or bundle of bars shall be identified by marks stamped on hot or cold or painted on or by any other means. The identifying marks shall contain the following information:

- Name of the producer or his trade.

- Standard to which the bars have been manufactured.
- The class type and strength.
- The diameter.
- The number of the test certificate.

4.2 Storage

The method of storage shall be approved by the Supervisor. Reinforcing bars shall be stored in racks or platforms above the surface of ground and shall be protected free from scaling, rusting, oiling, coatings, damage, contamination and structural defects prior to placement in works. Bars of different diameters and grades of steel reinforcement shall be kept separately.

**5. BAR BENDING SCHEDULES**

The Contractor shall prepare bar bending schedules of all the reinforcing steel bars and these bar bending schedules shall be submitted to the Supervisor for his approval. All detailing shall be done as per AC, standards AC1-315 & 318. The Contractor shall obtain approval of the bar bending schedules before starting actual bar bending works.

**6. FABRICATING, BENDING & PLACING**

6.1 Bars used for concrete reinforcement shall be fabricated in accordance with the dimensions shown in the bar-bending schedule approved by the Supervisor.

6.2 The cutting tolerance for all bars shall be  $\pm 25$ mm.

6.3 Where an overall or an internal dimension of a bent bar is specified in the schedule, the bending tolerance, unless otherwise stated, shall be as in Table 1.

*Table 1: Bending Tolerances*

Dimensions of bent bars		Tolerance	
Over mm	Up to & including mm	plus mm	minus mm
--	910	5	5
910	1820	5	5
1820		5	25

6.4 Reinforcement shall not be bent or straightened in a manner that will injure the material.

No bars shall be bent twice in the same place, nor shall they be straightened after bending.

Unless permitted by the Supervisor, reinforcement shall not be bent after being partially embedded in hardened concrete.

Bars which depend for their strength on cold working shall not be heated for any reason.



- 6.5 Welding shall be permitted for bars only under suitable conditions and with suitable safeguards in accordance with BS 693, BS 1856, or AWS D12.1, provided the type of reinforcing bar has the required welding properties. Tack welding may be used to fix in position bars that cross each other, only with prior approval of the Supervisor. Welding shall be done in locum for structural steel & metal works.
- 6.6 No splice of reinforcement shall be made except as shown on the working drawings.
- 6.7 Reinforcement is to be accurately placed as shown in the drawings, and secured against displacement by using 18-20 gauge black annealed wire ties or suitable slips at intersections and supported from the formwork by using concrete, metal or plastic chairs and spacers or hangers of an approved pattern. Where concrete blocks are used for ensuring the cover, they shall be made of mortar not leaner than 1 part of cement to 2 parts of sand.

Where the concrete surface will be exposed to the weather in the finished structure, the portions of all accessories in contact with the formwork shall be galvanized or shall be made of plastic.

- 6.8 Concrete clear cover for reinforcing steel shall be as follows:

<b>Structural Members</b>	<b>Minimum Cover, cm</b>
a) Concrete cast against and Permanently exposed to earth	7.5
b) Concrete exposed to earth or weather:	
For reinforcing bars $\Phi$ 18 or larger	5
For reinforcing bars less than $\Phi$ 18	4
c) Concrete not exposed to weather or in contact with ground:	
Slabs, Walls	2
For reinforcing bars $\Phi$ 28 or larger	4
For reinforcing bars less than $\Phi$ 28	2
Beams, Columns:	
For reinforcing bars $\Phi$ 18 or larger	2
For reinforcing bars less than $\Phi$ 18	1.5

- 6.9 Tolerance on depth (d) and at least cover of concrete on bending member

1. Concrete cover to formed surfaces	$\pm$ 5 mm
2. Minimum spacing between bars	- 5 mm
3. Top bars in slabs and beams	

- a. Members 8 inch deep or less  $\pm 5$  mm
  - b. Members more than 8 inch but not over 2 feet deep  $\pm 12$  mm
  - c. Members more than 2 feet deep  $\pm 25$  mm
  - 4. Crosswise of members: spaced evenly within 50 mm
  - 5. Lengthwise of members  $\pm 50$  mm
- 6.10 Bars may be moved as necessary to avoid interference with other reinforcing steel, conduits, or embedded items. If bars are moved more than one bar diameter or enough to exceed the above tolerances, the resulting arrangement of bars shall be subject to approval of Supervisor.
- 6.11 Vertical bars in columns shall be offset at least one bar diameter at lapped splices. To ensure proper placement, templates shall be furnished for all column dowels.
- 6.12 Exposed reinforcement intended for bonding with future extensions is to be effectively protected from corrosion. Protection is also to be provided to reinforcement partly built into concrete where the exposed part is to be built into later concrete.
- 6.13 All reinforcement, at the time concrete is placed, shall be free of loose mill scale, loose rust mud, oil grease, or other materials that may adversely affect or reduce the bond.
- 6.14 No concreting is to be carried out until the reinforcement has been checked and approved by the Supervisor.

## 7. MEASUREMENT & PAYMENT

### 7.1 General

Except otherwise specified herein or elsewhere in the Contract Documents, no measurement and payment will be made for the under mentioned specified works related to the relevant items of the Bills of Quantities. The cost thereof shall be deemed to have been included in the quoted unit rate of the respective items of the Bills of Quantities.

The rates quoted by the Contractor in the Bill of Quantities shall include work to be executed under these specification in any floor and at any height except where otherwise specifically stated in the relevant item of Bill of Quantities and the Contractor shall not be entitled to any claim or claim any compensation on this account.

Providing and installing cover blocks, chairs, supports, hooks, spacers, binding wires, and laps not shown on drawings including wastage and rolling margin. Laps shown on drawings shall be payable.

### 7.2 Mild Steel and Deformed Steel

#### 7.2.1 Measurement :

Measurement for acceptably completed works of reinforcement according to bar bending schedules approved by the Supervisor shall be made by weight.

Computed on the bases of Table 2. The Contractor shall not claim for the difference in the actual weights of bars and their standard weights given in Table 2.

*Table 2: Standard Weights of Reinforcing Steel*

Nominal Bar Diameter (mm)	Weight Kg/m.
6	0.22
8	0.395
10	0.617
12	0.888
14	1.210
16	1.580
18	2.000
20	2.470
22	2.980
25	3.380
28	4.830
30	5.550
32	6.310

#### 7.2.2 Payment:

Payment will be made for acceptable measured quantity of reinforcement on the basis of unit rate per tonne quoted in the Bill of Quantities and shall constitute full compensation for all the works related to the item.

The rate quoted include all lead/lift required for steel fabrication & placement at/in any floor and at any height as per drawings.

## **SECTION 2300 - PLAIN AND REINFORCED CONCRETE**

### **1. SCOPE**

The work under this section of the specification consists of furnishing all plant, labour, equipment, appliances and materials and in performing all operations in connection with the supply and installation of plain and reinforced concrete work complete in any floor and at any height as per drawings except where specifically stated in the relevant item of Bill of Quantities, in strict accordance with this section of the specifications and the applicable drawings, and subject to the terms and conditions of the Contract. The scope of this section of specification is covered with detailed specifications as laid down herein.

### **2. GENERAL**

- 2.1 Full co-operation shall be given to trades like electrical, mechanical and other services.
- 2.2 Suitable templates or instructions or both shall be provided for setting out items not placed in the forms. Embedded items and other materials for mechanical and electrical operations shall have been completed, inspected, tested and approved before concrete is placed.
- 2.3 For special concrete finish and for special methods of construction (e.g. slip forms), formwork shop drawings shall be designed and prepared by the Contractor, at his own cost. Approval of shop drawings as well as that of actual samples of concrete finish shall be obtained before work is commenced.

### **3. APPLICABLE STANDARDS**

Latest editions of the following ASTM Standards are relevant to these specifications wherever applicable.

#### **3.1 ASTM (American Society for Testing and Materials)**

B	370	Copper sheet and strip for building construction.
C	33	Concrete Aggregates.
C	40	Organic impurities in sand for concrete.
C	87	Effect of organic impurities in fine aggregates on of mortar.
C	88	Soundness of aggregates.
C	94	Ready mixed Concrete.
C	109	Compressive strength of hydraulic cement mortars.
C	117	Material finer than No.200 (0.075mm) sieve.
C	123	Light-weight pieces in aggregates.
C	125	Concrete and concrete aggregates.
C	127	Specific gravity and absorption of coarse aggregate.
C	128	Specific gravity and absorption of fine aggregate.
C	131	Resistance to abrasion of small size coarse aggregates.
C	136	Sieve or screen analysis of fine and coarse aggregate.
C	142	Clay lumps and friable particles in aggregates.

C	143	Slump of Portland Cement Concrete.
C	144	Aggregate for masonry mortar.
C	150	Portland cement.
C	156	Water retention by concrete curing material
C	171	Sheet material for curing concrete.
C	185	Air content or hydraulic cement mortar.
C	188	Density of hydraulic cement.
C	191	Time of setting of hydraulic cement by vicat needle.
C	260	Air entraining admixtures for concrete.
C	289	Potential reactivity of aggregate.
C	309	Liquid membrane-forming compounds for curing concrete.
C	330	Lightweight aggregates for structural concrete.
C	331	Lightweight aggregates for concrete masonry.
C	332	Lightweight aggregates for insulating concrete.
C	494	Chemical admixtures for concrete.
C	535	Resistance to abrasion of large size coarse aggregates.
C	567	Unit weight of structural lightweight concrete.
D	75	Aggregate sampling.
D	994	Preformed expansion joint filler for concrete.
D	1190	Concrete joint sealer (hot poured elastic type).
D	1751	Preformed expansion joint filler for concrete paving and structural construction.
D	1752	Preformed sponge rubber and cork expansion joint fillers for concrete paving and structural construction.
D	1850	Concrete joint sealer (cold application type).
E	11	Wire cloth sleeves for testing purposes.
E	96	Water vapor transmission of materials in sheet form.
E	154	Materials for use as vapor barrier under concrete slabs.
E	337	Relative humidity by wet and dry bulk psychomotor.

### 3.3 ACI (American Concrete Institute)

211.1	Recommended practice for selecting proportions for normal and heavy weight concrete.
214	Recommended practice for evaluation of strength test result of concrete
301	Specifications for structural concrete for buildings.
304	Recommended practice for measuring, mixing, transporting and placing concrete.
305	Hot weather concreting.
308	Recommended practice for curing concrete.
309	Recommended practice for consolidation of concrete.
318	Building code requirements for reinforced concrete.
347	Recommended practice for concrete formwork.
512	Precast structural concrete in building.
517	Low pressure steam curing.
533	Fabrication, handling and erection of precast concrete wall panels.
CP 116	Structural use of precast concrete.
CP 5337	the structural use of concrete for retaining aqueous liquids.

In addition, the latest editions of other Pakistan and British Standards, American Concrete Institute Standards, American Society for Testing and Materials Standards and other Standards as may be specified by the Supervisor for special Materials and Construction are also relevant.

#### 4. MATERIALS

##### 4.1 Aggregates

4.1.1 The sources of supply of all fine and coarse aggregates shall be subject to the approval of the Supervisor.

4.1.2 All fine and coarse aggregates shall be clean and free from clay, loam, silt and other deleterious matter. If required, the Supervisor reserves the right to have them washed by the Contractor at no additional expense. Coarse and fine aggregates shall be delivered and stored separately at site. Aggregates shall not be stored on muddy ground or where they are likely to become dirty or contaminated.

4.1.3 Fine aggregate shall be hard coarse sand, crushed stone or gravel screenings and shall conform to requirements of PS 243 and/or BS 882 and/or ASTM C 33. Only fine aggregate of grading zones 1 to 3 (BS 882) shall be used.

4.1.4 Coarse aggregate shall be gravel or crushed stone of hard, durable material free from laminated structure and conforming to ASTM C 33 graded as follows for use in mass concrete as in foundations:

<u>Total Passing B.S. Sieve</u>	<u>Percent by weight</u>
3 in. (76.20 mm) :	100
1.5 in. (38.10 mm) :	95-100
0.75 in. (19.05 mm) :	30-70
0.38 in. (9.52 mm) :	10-35
0.19 in. (4.76 mm) :	0-5

Coarse aggregate for all cast-in-place concrete other than mass concrete as for foundations shall be graded with the following limits:

<u>Total Passing B.S. Sieve</u>	<u>Percent by weight</u>
1.5 in. (38.10 mm) :	100
0.75 in. (19.05 mm) :	95-100
0.38 in. (9.52 mm) :	25-55
0.19 in (4.76 mm) :	0-10

4.1.5 Wherever feasible, the nominal maximum size of aggregate for cast- in- place reinforced concrete slabs and other members shall be 3/4 inch. If there are difficulties in placing such a concrete the maximum size may be restricted to 1/2 inch provided the requirements for strength are satisfied. The grading requirements of 1/2 inch or 3/8 inch down aggregate shall be agreed to with the Supervisor as per relevant ASTM/BS standards.

4.1.6 The nominal maximum size of the aggregate for precast concrete shall not be larger than one fifth of the narrowest dimension between sides of forms, or one-third of the depth of slabs or three-fourths of the minimum clear distance between reinforcing bars or between bars and forms, whichever is least. In Precast columns the nominal maximum size of the aggregate shall be limited as above but shall not be larger than two-thirds of the minimum clear distance between bars.

4.1.7 Coarse aggregates in Precast concrete of normal weight may be of one maximum size for all concrete placed in 1 day when quantities to be placed are too small to permit economical use of more than one mix design.

When a single mix design is so used, the maximum nominal size shall be as required for the most critical condition of concreting, in accordance with the requirements of clause (4.1.6) above.

4.1.8 Except where it can be shown to the satisfaction of the Supervisor that a supply of properly graded aggregate of uniform quality can be maintained over the period of the work, the grading of the aggregates shall be controlled by obtaining the 3/4" maximum nominal size, the different sizes being stocked in separate stock piles and recombined in the correct proportion for each batch at the batching plant. The materials shall be stock-piled for a period before use so as to drain nearly to constant moisture content (as long as site and other conditions permit, preferably for at least a day). The grading of the coarse and fine aggregates shall be tested at least once for every 100 tons supplied, to ensure that the grading is uniform and same as that of the samples used in the preliminary tests.

4.1.9 For use in fire proof concrete, the aggregates shall be fire clay and semi-acidic fine ground. The use of broken fire clay bricks as coarse aggregate and waste of semi-acidic refractory particles as fine aggregate can be allowed.

4.1.10 Gravel or Crushed Stone for the roofing system: This material is placed on top of the Isogam roofing material to prevent shrinkage and movement of the Isogam. The size of the gravel for this application shall be 9-10 mm.

## 4.2 Cement

4.2.1 The cement shall be fresh and of approved origin and manufacture. It shall be one of the following as may be specified by the Supervisor.

- Ordinary or Rapid Hardening Portland cements complying with the requirements of PS 232 or BS 12 or ASTM C 150.
- Sulphate Resisting Portland/Cement complying with the requirements of ASTM C 150.

4.2.2 Unless otherwise specified, ordinary Portland cement complying with the requirements of BS 12 shall be used.

4.2.3 For all fair faced concrete it will be necessary to use approved cement with a view to obtain light shade concrete as approved by the Supervisor.

- 4.2.4 The Contractor shall supply to the Supervisor at fortnightly intervals, test certificates with the appropriate standard in respect of the samples of cement from the work-site. These tests shall be carried out in a laboratory approved by the Supervisor.
- 4.2.5 Only one brand of each type of cement shall be used for concrete in any individual member of the structure. Cement shall be used in the sequence of receipt of shipment, unless otherwise directed.
- 4.2.6 There shall be sufficient cement at site to ensure that each section of work is completed without interruption.
- 4.2.7 Cement reclaimed from cleaning of bags or from leaky containers shall not be used.
- 4.2.8 The Contractor shall provide and erect (at his cost) a suitable plain, dry, well ventilated, weatherproof and water proof shed of sufficient capacity to store the cement.
- 4.2.9 Cement shall be used as soon as possible after delivery and cement which the Supervisor consider has become stale or unsuitable through absorption of moisture from the atmosphere or otherwise shall be rejected and removed immediately from the site at the Contractor's expense. Any cement in containers damaged so as to allow the contents to spill or permitting access of the atmosphere prior to opening of the container at the time of concrete mixing shall be rejected and removed immediately from the site at the Contractor's expense.
- 4.2.10 The mixing together of different types of cement will not be permitted.

#### 4.3 Water

Only clean water from the city supply, tube well installed at the site or from other sources approved by the Supervisor shall be used. The Contractor shall supply sufficient water for all purposes, including mixing the concrete, curing and cleaning plant and tools. Where doubt exists as to the suitability of the water, it shall be tested in accordance with BS 3148. Where water can be shown to contain any sugar or an excess of acid, alkali or salt, the Supervisor may refuse to permit its use.

In case of doubt, the Supervisor may require that concrete mixed with water proposed to be used should not have a compressive strength lower than 90 percent of the strength of concrete mixed with distilled water.

#### 4.4 Additive

All additives such as foaming and water proofing agents shall be from a manufacturer approved by the Supervisor.

Air Entraining Admixtures shall conform to ASTM C 260. Other Admixtures shall conform to ASTM C 494.

### 5. **NOMINAL CONCRETE MIXES**

#### 5.1 Proportions of Mix

5.1.1 Cement and aggregates:



Cement, fine aggregate and the coarse aggregate shall be weighed separately. The proportions of cement to fine aggregate and coarse aggregate shall be adjusted so as to provide the concrete of the required crushing strength when tested as set out in Table 1.

5.1.2 The Contractor shall regulate and arrange mixing of the ingredients for the designed mix of the concrete by weight batching. The cost of designing the mix shall be borne by the Contractor.

5.1.3 Water/Cement ratio:

The quantity of water used shall be just sufficient to produce dense concrete of adequate strength and workability for its purpose. For all external work and foundations the water/cement ratio should not exceed 0.55 for concrete Class A, B and C.

5.1.4 Workability:

The workability shall be controlled by direct measurement of the water content, allowance being made for any water in the fine and coarse aggregates. The concrete shall be just sufficiently workable to be placed and compacted, without difficulty, by the available means.

Workability' shall be determined by either the slump or compaction factor tests as directed by the Supervisor and these shall be performed in accordance with the methods given in ASTM C 143.

The slump or compaction factor for each class of concrete shall be determined during the preliminary Test mixes and the value obtained shall not be modified without the written consent of the Supervisor. Unless otherwise permitted or specified, the concrete shall be proportioned and produced to have a slump of 3 inch or less for consolidation by vibration. A tolerance of up to 1 inch above the indicated maximum shall be allowed for individual batches provided the average for all batches or the most recent 10 batches tested, whichever is fewer, does not exceed the maximum limit. Concrete of lower than usual slump may be used provided it is properly placed and consolidated.

5.2 Strength requirements for concrete

5.2.1 Portland cement concrete when aggregates comply with BS 882.

5.2.2 Concrete made with Portland cement shall comply with the strength requirements of Table 3, columns 4&6 (Works Test).

**Table 3: Strength requirements for Portland concrete with aggregates Complying with BS. 882.**

<b>Class</b>	<b>Min Cement per Cu.ft of concrete (lb.)</b>	<b>Min Cube crushing strength at 28 days (psi)</b>	<b>Man. water Per 110 lb. bag of cement (gallon)</b>
--------------	---	--	--

1	2	3	4
A	30.00	4500	4.40
B	22.00	3750	5.06
C	18.00	3000	5.28
D	13.00	1500	7.05
E	9.50	1000	7.27

Note: Conversion Factors.    1 psi = 0.06897 MPa    1 gal = 4.54 liter  
    1 lb. = 0.4537 Kg.        1 cu.ft. = 0.028 cum.

5.2.3 The strengths given in Table 1 are based on the assumption that average temperature is 20 degree C. Where accurate records of temperature are kept, allowance may be made for change of temperature or the cubes may be tested at the equivalent maturity.

5.2.4 Unless otherwise stated, the types of concrete shall be classified on the basis of compressive strength requirements. The Contractor shall provide Mix design by weight for each class of concrete.

Manufacture 12 test cubes for each 3 mix design batches (6 x 6 x 6) inches in accordance with the Mix design batching by weight and test 3 cubes each at 3,7,14 & 28 days intervals in the presence of Supervisor's Representative and submit all relevant data and results of tests for approval of the Supervisor. The Contractor shall obtain approval from the Supervisor in writing for each Mix design before producing the actual concrete for the Works.

No payments for producing the Mix design, manufacture of test cubes and testing shall be paid. The Contractor shall include this cost in the relevant item of concrete.

5.3 **Batching**

5.3.1 All cement, including cement supplied in bulk, shall be batched by weight. A bag of cement may be taken as weighing 110 lb. with the prior approval of the Supervisor.

5.3.2 Aggregates shall be batched by weight, due allowance being made for water content. Aggregates may be batched by volume through conversion of weigh batching, only with the prior permission of the Supervisor. The apparatus for weight batching may be an integral part of the mixer or a separate unit of a type approved by the Supervisor. It shall be accurate within 2% and shall be checked for accuracy at least once a week.

5.3.3 The quantity of additives i.e. foaming and water proofing agents etc. shall be as prescribed by the manufacturer or as directed by the Supervisor.

5.3.4 Where the batching plant is of the type in which cement and aggregates are weighed in the same compartment, the cement shall be introduced into the compartment between two sizes of aggregates.

5.3.5 Each batch shall be so charged into the mixer that some water will enter in advance of the cement and aggregates. Water shall continue to flow for a period,

which may extend to the end of the first 25 percent of the specified mixing time. Controls shall be provided to prevent batched ingredients from entering the mixer before the previous batch has been completely discharged.

#### 5.4 **Mixing**

5.4.1 The concrete shall be mixed in an approved batch mixer conforming to the requirements of BS 1305. It shall be fitted with the manufacturer's plate stating the rates, capacity and the recommended number of revolutions per minute and shall be operated in accordance therewith. It shall be equipped with a suitable charging mechanism and an accurate water-measuring device. The mixer shall be capable of thoroughly combining the aggregates, cement and water into a uniform mass within the specified mixing time and of discharging the concrete without harmful segregation.

5.4.2 Mixing shall continue for the period recommended by the mixer manufacturer or until there is apparently a uniform distribution of the materials and the mass is uniform in colour, whichever period is longer. If it is desired to use a mixing period of less than 1-1/2 minutes, the Supervisor's approval shall be obtained in writing.

5.4.3 Controls shall be provided to ensure that the batch cannot be discharged until the required mixing time has elapsed. At least three quarters of the required mixing time shall take place after the last of the mixing water has been added.

5.4.4 The interior of the mixer shall be free of accumulations that will interfere with mixing action. Mixing blades shall be replaced when they have lost 10 percent of their original height.

5.4.5 Concrete shall be mixed only in quantities for immediate use. Concrete which has set shall not be retempered, but shall be discarded.

#### 5.5 **Transporting**

5.5.1 The concrete shall be transported from the place of mixing to the place of final deposit as rapidly as practicable by means, which will prevent segregation or loss of ingredients. All skip vehicles, or containers used for transporting the concrete shall be thoroughly cleaned.

5.5.2 During hot or cold weather, concrete shall be transported in deep containers, on account of their lower ratios of surface area to mass, which reduces the rate of loss of water, by evaporation during hot weather and loss of heat during cold weather.

#### 5.6 **Placing**

5.6.1 Before placing of concrete, formwork shall have been completed; water shall have been removed; reinforcement shall have been secured in place; expansion joint material, anchors and other embedded items shall have been kept in position; and the entire preparation shall have been approved by the Supervisor.

No concrete is to be placed into the foundation trenches until the ground to receive the same has been examined and approved by the Supervisor for this purpose.

- 5.6.2 Concrete shall be deposited continuously, or in layers of such thickness that no concrete will be deposited on concrete, which has hardened sufficiently to cause the formation of seams or planes of weakness within the section. If a section cannot be placed continuously, construction joints shall be located as shown in the Contract Documents or as approved by the Supervisor. Placing shall be carried out at such a rate that the concrete which is being integrated with fresh concrete is still plastic. Concrete which has partially hardened shall not be deposited. Temporary spreaders in forms shall be removed when the concrete placing has reached an elevation rendering their services unnecessary. They may remain embedded in the concrete only if made of metal or concrete and if prior approval has been obtained.
- 5.6.3 The actual sequence of construction proposed by the Contractor shall be subject to the Supervisor's approval before construction starts on any part of the structure, and this sequence shall not be varied without the Supervisor's approval.
- 5.6.4 The concrete after it has been mixed shall be placed as soon as it is practicable. Once the concrete has left the mixer, no more water shall be added, although the concrete may be mixed or agitated to help maintain workability. The concrete shall not be used if, through any cause, the workability of the mix at the time of placing is too low for it to be compacted fully and to an acceptable finish by whatever means available.

The time between mixing and placing should be reduced, if the mix is richer or the initial workability of the mix is lower than normal, or if a rapid hardening cement or an accelerator is used, or if the work is carried out at a high temperature or exposed to a drying atmosphere.

The Contractor shall ensure that the delay between mixing and placing including consolidation does not exceed 45 minutes under any circumstances. Any concrete which does not satisfy this requirement shall be rejected.

- 5.6.5 Concrete shall be deposited as nearly as possible in its final position to avoid segregation due to rehandling or flowing. In no circumstances may concrete be railed or made to flow along the forms by the use of vibrators.

Concreting shall be carried on as a continuous operation using methods, which shall prevent segregation or loss of ingredients.

- 5.6.6 The free fall of concrete shall not be allowed to exceed 6 feet. Where it is necessary for the concrete to be lowered more than this depth, it is not to be dropped into its final position, but shall be placed through pipes fed by a hopper. When a pipe is used for placing concrete the lower end shall be kept inside or close to the freshly deposited concrete. The size of the pipe shall be not less than 9 inch in diameter.
- 5.6.7 'Mass-concrete' shall be placed in layers approximately 18 inch thick. Vibrator heads shall extend into the previously placed layer.
- 5.6.8 The workmen carrying concrete to the site, and all other workmen moving about on the reinforcement before the concrete is placed, shall move only along runways or planks placed for the purpose and no person shall be allowed to walk on the reinforcement itself.

- 5.6.9 Prior to the laying of concrete on load bearing masonry walls, bearing plates and at other points, as may be directed by the Supervisor, the surface will be brought to a true, hard and smooth level surface using cement sand mortar in the ratio of 1 volume of cement to 3 volumes of sand. Two layers of building paper weighing .082 lb./ft<sup>2</sup> will then be laid flat to separate the concrete from the surface on which it is to be laid.

5.7 **Construction Joints**

- 5.7.1 Concreting shall be carried out continuously up to construction joints, the position and arrangement of which shall be predetermined by the Supervisor.
- 5.7.2 Joints not shown on the drawings shall be so made and located as to least impair the strength of the structure and shall need prior approval of the Supervisor. In general, they shall be located near the middle of the spans of slabs and beams unless a secondary beam intersects a main beam at this point, in which case the joint in the main beam shall be offset a distance equal to twice the width of the secondary beam. Joints in walls and columns shall be at the underside of floors, slabs or beams and at the top of footings or floor slabs. Beams, brackets, columns capitals, haunches and drop panels shall be placed at the same time as slabs. Joints shall be perpendicular to the main reinforcement.
- 5.7.3 All reinforcing steel shall be continued across joints. Keys and inclined dowels shall be provided as directed by the Supervisor. Longitudinal keys at least 1-1/2 inches deep shall be provided in all joints in walls and between walls and slabs or footings.
- 5.7.4 When the work has to be resumed on a surface which has hardened, such surface shall be roughened in an approved manner which will expose the aggregate uniformly and will not leave laitance, loosened particles of aggregate or damaged concrete at the surface.
- 5.7.5 The hardened concrete of construction joints and of joints between footings and walls or columns, between walls or columns and beams or floors they support, joints in un-exposed walls and all others not mentioned herein shall be dampened (but not saturated) immediately prior to placing of fresh concrete.
- 5.7.6 The hardened concrete of joints in exposed work, joints in the middle of beams, and slabs; and joints in work designed to contain liquids shall be dampened (but not saturated) and then thoroughly covered with a coat of cement grout similar in proportions to the mortar in the concrete. The grout shall be as thick as possible on vertical surfaces and at least 1/2 inch thick on horizontal surfaces. The fresh concrete shall be placed before the grout has attained initial set.
- 5.7.7 Where the concrete has not fully hardened, all laitance shall be removed by scrubbing the wet surface with wire or bristle, and brushed, care being taken to avoid dislodgment of particles of aggregate. The surface shall then be coated with neat cement grout. The first layer of concrete to be placed on this surface shall not exceed 6 inch in thickness, and shall be well rammed against old work, particular attention being paid to corners and closed spots.
- 5.7.8 Stop ends for movement joints or construction joints shall be made by splitting them along the lines of reinforcement passing through them, so that each portion can be positioned and removed separately without disturbance or shock to the

reinforcement or the concrete. Stop ends made of expanded metal or similar material may only be left permanently in the concrete with prior written approval of the Supervisor. Where such stop ends are used, no metal may be left permanently in the concrete closer to the surface of the concrete than the specified cover to the reinforcement.

5.8 **Expansion Joints**

Expansion joints shall be provided wherever indicated on the Drawings or as directed by the Supervisor. In no case shall the reinforcement, corner protection angles, or other embedded items be permitted to extend continuously through any expansion joint.

All expansion joints shall be carefully placed so as not to be displaced during concreting. The method of placing the expansion joints shall be strictly in accordance with the Drawings and/or as directed by the Supervisor. All materials for use in the expansion joints shall have prior approval of the Supervisor before placing order for supply.

5.9 **Embedded Items**

5.9.1 The material, design and location of water stops in joints shall be as indicated in the Contract Documents. Each piece of pre-molded water stop shall be of maximum practicable length in order that the number of end joints will be held to a minimum.

Joints at intersections and at ends of pieces shall be made in the manner most appropriate to the material being used. Joints shall develop effective water-tightness fully equal to that of the continuous waterstop material, shall permanently develop not less than 50 percent of the mechanical strength of the parent section and shall permanently retain their flexibility.

5.9.2 Electric conduits and other pipes which are planned to be embedded shall not, with their fittings, displace more than four percent of the area of the cross section of a column on which stress is calculated or which is required for fire protection. Sleeves, conduits, or other pipes passing through floors, walls, or beams shall be of such size or in such location as not to impair unduly the strength of the construction; such sleeves, conduits, or pipes may be considered as replacing structurally in compression the displaced concrete, provided that they are not exposed to rusting or other deterioration, are of uncoated or galvanized iron or steel not thinner than standard steel pipe, have a nominal inside diameter not over 2 inch and are spaced not less than three diameters on centres. Except when plans of conduits and pipes are approved by the Supervisor, embedded pipes and conduits other than those merely passing through, shall not be larger in outside diameter than one third the thickness of the slab, wall, or beams in which they are embedded nor so located as to impair unduly the strength of the construction. Sleeve pipes, or conduits of any material not harmful to concrete and within the limitations of this section may be embedded in concrete with the approval of the Supervisor provided they are not considered to replace the displaced concrete.

5.9.3 All sleeves, inserts, anchors, and embedded items required for adjoining work or for its support shall be placed prior to concreting.

All Contractors whose work is related to the concrete or must be supported by it shall be given ample notice and opportunity to introduce and/or furnish embedded items before the concrete is placed.

5.9.4 Expansion joint material, waterstops and other embedded items shall be positioned accurately and supported against displacement. Voids in sleeves, inserts and anchor slots shall be filled temporarily with readily removable material to prevent the entry of concrete into the voids.

#### 5.10 **Pre-Cast Concrete**

Pre-cast concrete units shall be fair faced, cast to the sizes and dimensions as indicated on the Drawings. The concrete used for pre-cast units shall conform to the specifications laid down for cast in situ reinforced cement concrete unless otherwise required and directed by the Supervisor.

The Contractor shall be required to submit a sample of pre-cast unit for the approval of the Supervisor; all pre-cast units shall strictly conform to the approved sample.

Pre-casting platform of the size and at the location approved by the Supervisor shall be constructed. The concrete in one pre-cast unit shall be placed in one operation, in accordance with the details shown on the Drawings.

The material and design of formwork and the method of pre-casting the units shall be approved by the Supervisor.

The erection/installation and removal of the pre-cast units from the pre-casting platform shall not be permitted until and unless they are properly cured to the satisfaction of the Supervisor.

All pre-cast units shall be smoothly finished to the required lines, grades, angles, etc. Holes, grooves, pockets and hooks shall be provided as shown and/or as directed by the Supervisor. The units shall be properly stacked on a platform without causing any cracks and damages. Curing of all the pre-cast units shall be done in accordance with the relevant BS code/approval of the Supervisor.

##### 5.10.1 Erecting Pre-cast Units

All the pre-cast units shall be transported and erected into position in a manner as approved by the Supervisor.

The Contractor shall submit his proposal in this regard and obtain approval from the Supervisor in advance.

##### 5.10.2 Lifting Beams

The Contractor shall use lifting beams at his own cost for erecting pre-cast members where the Supervisor so directs. Lifting beams shall be supplied and erected by the Contractor, at his own cost, at all points where lifting is necessary for maintaining the plant but is inaccessible to mobile cranes or, alternatively, covered by overhead travelling cranes. The Contractor, however, is to supply the trolleys and erect them on the lifting beams, and to test operation of installed equipment.

#### 5.11 **Cement Concrete Pavements**

For all concrete work relevant specifications of this section shall apply.

##### 5.11.1 Side Forms and Construction

Side forms shall be of steel or any other suitable material and of a design as approved by the Supervisor.

In general, only materials and methods that have proved their acceptability by past performance will be considered. All form shall be constructed so that they can be removed without hammering or prying against the concrete.

Horizontal joints in the forms will not be permitted. Forms shall be thoroughly cleaned and oiled with linseed/mineral oil shall be given two coats of niter-cellulose lacquer each time they are used.

The forms shall be set on a thoroughly compacted base true to line and level and firmly secured in position by appropriate methods. Conformity with the alignment and levels shown on the Drawings shall be checked as and when required by the Supervisor. Where necessary corrections shall be made immediately before placing the concrete; where any form has been disturbed it shall be reset and rechecked.

Pavements shall be constructed in panels of sizes as shown on the Drawings. The panels shall be laid alternately, the adjoining panels being concreted when the side forms are struck and the jointing materials placed, inspected and approved by the Supervisor. Each panel is to be concreted in one operation and no interruptions shall be permitted during the operation. The concrete shall be tipped from the trolley slightly in advance of the working place and then shoveled into position. The spreading shall be carried out very carefully. Compaction shall be done by means of vibro compactors of approved surface vibrators. If a vibro compactor is used, it shall be operated on the concrete and will not be allowed to strike or displace the forms. The spreading and compacting of the successive layers shall proceed without interruptions and as quickly as practicable so as to ensure that the slab is monolithic throughout its depth.

The wearing surface shall be laid while the base concrete is still wet and screened to line and level. When the initial set takes place the surface shall be troweled smooth with a steel trowel to provide a dense closed surface.

All the joints shall be carefully formed as shown on the Drawings or as directed by the Supervisor. The joint filler together with performed groove shall provide complete separation of adjacent slabs. The joints shall all be sealed with bitumen as shown on the Drawings and as directed by the Supervisor.

#### 5.11.2 Protection and Curing

##### General Requirements:

Concrete shall be protected adequately from injurious action by sun, rain, flowing water and mechanical injury, and shall not be allowed to dry form the time it is placed until the expiry of the minimum curing periods specified hereinafter. Water curing shall be accomplished by keeping the surface of the concrete continuously wet by covering with water or with approved water saturated covering. Where wood forms are left in place for curing, they shall be kept sufficiently damp at all times to prevent openings at the joints and drying out of the concrete. All portions of the structure shall be kept moist for the full curing periods, specified hereinafter.

When liquid membrane curing compound is used the surface of the concrete shall be protected from traffic or other abrasive action, that may break the membrane, for the full period of curing. The membrane curing compound shall be colourless or light coloured and shall be approved by the Supervisor and shall comply with ASTM Designation C 309.

##### - Curing Periods

The curing period shall be at least 10 days, or as directed by the Supervisor.



- Removal of Forms

The Contractor shall exercise great care in avoiding damage to joints, dowel bars etc., while removing the forms. Under no circumstances will the use of pry bars between the forms and pavement be permitted. Side forms shall not be removed until at least 40 hours have elapsed from the time of completing the concreting of the slab, which they contain. In no case shall forms be removed until the concrete has hardened sufficiently to permit removal without damage to the concrete. Concrete work shall be protected from injury resulting from the storage or movement of material during construction.

5.11.3 Finishing

All unformed surfaces shall be finished with a wood float except as otherwise specified. Visible vertical surfaces shall have all projections and irregularities removed. The entire surface shall be rubbed if required by the Supervisor, with a No. 16 carborundum brick, or other abrasive until even, smooth and of uniform appearance, and shall be shed clean. Plastering of surface, application of cement or other coating will not be permitted. All exposed corners shall be chamfered, 1"x 1" (2.5 cm x 2.5 cm) unless otherwise mentioned or shown on the plans or directed by the Supervisor. Concrete surfaces which will be covered with other materials shall be screeded without floating.

5.11.4 Spreading, finishing and floating of concrete in pavements

- General Requirements

The striking off, compacting and floating of concrete shall be done by mechanical methods, if approved by the Supervisor. Where the Supervisor determines that it is impracticable to use mechanical methods, manual methods of spreading, finishing and floating may be used on pavement lines as indicated on the Drawings.

- Mechanical Methods

The concrete shall be spread uniformly between the forms, immediately after it is placed, by means of an approved spreading machine. The spreader shall be followed by an approved finishing machine equipped with two oscillating or reciprocating screeds. The spreading machine or the finishing machine shall be equipped with vibrating equipment that will vibrate the concrete for the full paving width. Internal vibrators shall be used adjacent to the longitudinal edge of the pavement. These vibrators shall be attached to the rear of the spreading machine or to the finishing machine. Vibrators shall not rest on new pavements or side forms or in contact with any dowel bars and the arrangement of power supply to the vibrators shall be such that when the motion of machine is stopped, vibration shall cease. The rate of vibration shall be not less than 8000 vibrations per minute. The concrete shall be spread to full width before being struck off and compacted so that the surface will conform to the finished grade and cross-section as shown on the plans and at the same time leave sufficient material for the floating operation. The spreading & finishing machine shall move over the pavement as many times and at such intervals as may be required by the Supervisor to ensure thorough compaction.

Except as otherwise specified, after the pavement has been struck off and compacted, it shall be finished with an approved longitudinal float. The Contractor may use a longitudinal float composed of one or more cutting and smoothing floats suspended from and guided by rigid frame. The frame shall be carried by four or more visible wheels riding on and constantly in contact with the forms.

The contractor may use a longitudinal float which works with a sawing motion, while held in a floating position parallel to the road centre line and passing gradually from one side of the pavement to the other. Movements ahead, along the centre line of the road, shall be in successive advances of not more than half the length of the float.

Instead of using other type of longitudinal float a single machine, which will affect satisfactory compaction, finishing and floating may be used. This machine may be towed by a spreading machine. This combination, finishing floating machine shall be equipped with screeds and vibrators as hereinafter specified for spreading and finishing machine. Floating shall be accomplished by means of a non-oscillating float held in a suspended position from the frame.

If any spreading, finishing and floating equipment is not maintained in full working order or if the equipment as used by the Contractor proves inadequate to obtain the results prescribed, such equipment shall be improved or satisfactory equipment substituted or added at the direction of the Supervisor.

- **Manual Methods**

When striking-off and compacting by manual methods is permitted, the concrete shall be levelled and then struck-off to such an elevation that, when properly compacted, the surface will conform to the required grade and cross-section. The strike board shall be moved forward with a combined longitudinal and transverse motion, the manipulation being such that neither ends is raised from the side forms during the process. While striking off, a slight excess of concrete shall be kept in front of the cutting edge at all times. Prior to tamping, the concrete along the forms shall be thoroughly spaded or vibrated. The entire area of pavement shall be tamped or vibrated a manner that will ensure maximum compaction. The concrete shall be brought to the required grade and shape by the use of a tamper consisting of a heavy plank whose length exceeds the width of the pavement by 1 foot or by the use of a mechanical vibrating unit spanning the full width of the spread. The tamper shall be constructed with properly trussed roads to stiffen it and prevent sag and shall be shod with a heavy strip or metal for a tamping surface. The tamper shall be moved with a combined tamping and longitudinal motion, raising it from side form and dropping it so that the concrete will be thoroughly compacted and rammed into place. A small surplus material is compacted and rammed into front of the tamper or vibrating unit and tamping or vibrating shall continue until the true cross-section is obtained and the mortar flushes slightly to the surface.

On grades in excess of 5 percent where hand methods are permitted, a little strike board shall follow at a speed of 25 ft to 50 ft per hour back of the heavy strike board, and shall be used in the same way, so as to remove waves caused by flow of concrete.

Where hand tamping is permitted, not less than two strike boards or tampers shall be used for production in excess of 10 m<sup>3</sup>. After the concrete has been compacted, it shall be smoothed with a wooden float where necessary, as directed by the Supervisor.

- Longitudinal Floating

Manual floats shall be at least 3.5 m. in length not less than 6 inches in width and shall be properly stiffened to prevent bending or warping. In using the float, it shall be held parallel to centre line of the pavement at all time and shall be moved laterally across the pavement from one side or edge to the other until all high areas are cut down and floated into depressions, leaving a surface that is smooth and true to grade. Batch transverse passage of the longitudinal manual float shall lap the proceeding passage by half.

- First Straight Edge Testing

Immediately following final floating the entire area of the pavement shall be tested with a 10-ft. (approx. 3. meters) straight edge. Any depressions found shall be immediately filled with fresh concrete which shall be struck off compacted and finished. High areas shall be worked down and refinished. The straight edge testing and refloating shall continue until the pavement has the required surface contour.

- Burlap (Coarse Canvas) Dragging

After the first straight edge testing and when most of the water sheet has disappeared from the surface and just before the concrete becomes non-plastic, the surface shall be dragged with a strip of burlap (coarse canvas) 0.9. to 3 m wide and having a length 1.20 m more than the width of the slab. The burlap shall be dragged along the surface of the pavement in a longitudinal direction. Burlap shall be clean and kept free from coatings of hardened concrete. It shall be moist at the time of use.

- Second Straight Edge Testing

After the concrete has hardened sufficiently to permit walking on it, the surface of the pavement shall again be tested with a 3 m. straight edge. Any portion of the pavement which shows a variation from the testing edge of more than 1/8 inch shall be corrected by cutting, or shall be removed and replaced at the expense of the Contractor.

5.11.5 Expansion and Contraction Joints

All the expansion and contraction joints shall be carefully formed as shown on the Drawings or as directed by the Supervisor. As regards dowel bars and joint assemblies, such stakes, brackets or other devices shall be used, as necessary to keep the entire joint assembly in true vertical and horizontal position. The joint filler together with the preformed groove shall provide complete separation of adjacent slabs. The joints shall all be sealed with the specified non-extruding sealing compound set in a 3/4 inch wide preformed chase as shown on the Drawings. The preformed chase shall be thoroughly cleaned of all dust, debris, stones or other hard material prior to its sealing. The riser of all joints shall be rounded to a radius as shown on the Drawings before the concrete hardens.

- ii The joints sealing compound shall be hot poured bitumen or approved sealing compound for concrete pavements complying with BS-2499 for hot tropical climates and heavy duty industrial site subject to severe exposure. All joints are to be filled with flexcell expansion joint filler, or an approved elastic,

compressible, durable and rot-proof equivalent of sufficient rigidity to enable it to be satisfactorily installed in the joint and resist deformation during the passage of the concreting equipment. The filler is to be of the same thickness as the joint width. Holes to accommodate the dowel bars shall accurately be drilled or punched out. Where shown on the Drawings, dowel bars of required diameter shall be placed at the specified spacing. The bars shall be lubricated with an approved lubricant. One end of the dowel bar at expansion joints shall be provided with a closely fitting sleeve 3 inch long, consisting of bitumen coated plastic or other approved material to permit expansion. A loose plug 1 inch deep of approved compressible filling material shall be inserted into the sleeve as shown on the Drawings at the end of the bar. All the dowel bars shall be mild steel bars of the size shown on the Drawings and shall conform to the requirements as specified in the section 'Concrete.

- iii Contraction joints shall be provided as shown on the Drawings.

The assembly and method of constructing the expansion joints/contraction joints shall be subject to the approval of the Supervisor.

## 5.12 **Consolidation**

5.12.1 All concrete shall be consolidated by vibration, spading, rodding or forking so that the concrete is thoroughly worked around the reinforcement, around embedded items and into corners of forms, eliminating all air or stone pockets which may cause honeycombing, pitting, or planes of weakness. Internal vibrators shall have a minimum frequency of 8000 vibrations per minute and sufficient amplitude to consolidate the concrete effectively. They shall be operated by competent workmen. Use of vibrators to transport within forms shall not be allowed. Vibrators shall be inserted and withdrawn at points approximately 46 cm apart. At each insertion, the duration shall be sufficient to consolidate the concrete but not excessive so as to cause segregation, generally from 5 to 15 sec. A spare Vibrator shall be kept on the job site during all concrete placing operations.

Where the concrete is to have an as-cast finish, a full surface of mortar shall be brought against the form by the vibration process, supplemented, if necessary, by spading to work the coarse aggregate back from the formed surface.

5.12.2 If there is any tendency for the mix to segregate during consolidation, particularly if this produces excessive laitance, the mix proportions shall be modified to effect an improvement in the quality of the concrete to the satisfaction of the Supervisor and in conformity with the provisions of Clause 5.

5.12.3 Vibrator shall not be allowed to contact the formwork for exposed concrete surfaces.

5.12.4 Mechanical vibrators shall be of a type suited in the opinion of the Supervisor to the particular conditions.

5.12.5 Over-vibration or vibration of very wet mixes is harmful and should be avoided.

## 5.13 **Curing and Protection**

5.13.1 Beginning immediately after placement, concrete shall be protected from premature drying, excessively hot or cold temperatures and mechanical injury and shall be maintained with minimum moisture loss at a relative constant temperature for the period necessary for hydration of the cement and hardening of the concrete. The materials and methods of curing shall be subject to approval of the Supervisor.

5.13.2 For concrete surfaces not in contact with forms, one of the following procedures shall be applied immediately after completion of placement and finishing:

- Ponding or continuous sprinkling.
- Application of absorptive mats or fabric kept continuously wet.
- Application of waterproof sheet materials approved by the Supervisor.
- Application of other moisture-retaining covering as approved.
- Application of a curing compound conforming to ASTM C 309.

The compound shall be applied in accordance with the recommendations of the manufacturer immediately after any water sheen, which may develop after finishing has disappeared from the concrete surface. It shall not be used on any surface against which additional concrete or other material is to be bonded unless it is proved that the curing compound will not prevent bond, or unless positive measures are taken to remove it completely from areas to receive bonded applications.

5.13.3 Moisture loss from surfaces placed against wooden forms or metal forms exposed to heating by the sun shall be minimized by keeping the forms wet until they can be safely removed. After form removal the concrete shall be cured until the end of the time prescribed for curing.

5.13.4 Curing in accordance with sub-clause 5.13.1 & 5.13.2 above shall be continued for at least 10 days in the case of all concrete except concrete with rapid-hardening Portland Cement for which the period shall be at least 3 days. Alternatively, if tests are made of cubes kept adjacent to the structure and cured by the same methods, moisture retention measures may be terminated when the average compressive strength has reached 70 percent of the minimum specified works cube strength. If one of the first four curing procedures of sub-clause 5.13.2 is used initially, it may be replaced by one of the other procedures of that sub-clause any time after the concrete is one day old provided the concrete is not permitted to become surface dry during the transition.

5.13.5 When the mean daily outdoor temperature is less than 5 degree C (41 deg. F) temperature of the concrete shall be maintained between 10 and 20 degrees C (50 to 68 deg. F) for the required curing period of sub-clause 5.13.4.

When necessary, arrangements for heating, covering insulation or housing the concrete work shall be made in advance of placement and shall be adequate to maintain the required temperature without injury due to concentration of heat. Combustion heaters shall not be used during the first 24 hours unless

precautions are taken to prevent exposure of the concrete to exhaust gasses, which contain carbon dioxide.

- 5.13.6 During hot weather when necessary, provision for wind-brakes, shading for spraying, sprinkling, ponding or wet covering with a light coloured material shall be made in advance of placement. Such protective measures shall be taken as quickly as concrete hardening and finishing operation will allow.
- 5.13.7 Changes in temperature of the air immediately adjacent to the concrete during and immediately following the curing period shall be kept as uniform as possible and shall not exceed 3 deg. C (37 deg. F) in any one hour or 10 degree C (50 deg. F) in any 24 hour period.
- 5.13.8 During the curing period, the concrete shall be protected from damaging mechanical disturbances, such as load stresses, heavy shock and excessive vibrations. All finished concrete surfaces shall be protected from damage by construction equipment, materials or methods by application of curing procedures, and by rain or running water. Self-supporting structures shall not be loaded in such a way as to over stress the concrete.

#### 5.14 **Works in Extreme Weather**

- 5.14.1 Unless adequate protection is provided and approval is obtained from the Supervisor, concrete shall not be placed during rain.

Rainwater shall not be allowed to increase the mixing water nor to damage the surface finish.

- 5.14.2 When the temperature of the surrounding air is expected to be below 5 deg. C during placing or within 24 hours thereafter, the temperature of the plastic concrete, as placed, shall be no lower than 13 deg. C for sections less than 12 inch in any dimension nor 10 deg. C for any other sections.

When necessary, concrete material should be heated before mixing and carefully protected after placing, in general, heating or mixing water alone to about 60 deg. C may be sufficient for this purpose. Dependence should not be placed on salt or other chemicals for the prevention of freezing. No frozen material or materials, containing ice shall be used. All concrete damaged by frost shall be removed. It is recommended that concrete exposed to the action of freezing weather should have entrained air and the water content of the mix should not exceed 5.5 gallon/bag of cement.

If water or aggregate is heated above 38 deg. C the water shall be combined with the aggregate in the mixer before cement is added. Cement shall not be mixed with water or with mixtures of water and aggregate having a temperature greater than 38 deg. C.

- 5.14.3 During hot weather, the temperature of the concrete as placed shall not be so high as to cause difficulty from loss of slump, flash set, or cold joints and should not exceed 32 deg. C. For massive concrete, this temp. Should not exceed 21 degree C. When the temp. of the concrete exceeds 32 degree C, precautionary measures approved by the Supervisor shall be put into effect. When the temperature of the steel is greater than 50 deg. C, steel forms and reinforcement shall be sprayed with water just prior to placing the concrete. The ingredients shall be cooled before mixing, or flaked ice or well crushed ice of a size that will

melt completely during mixing may be substituted for all part of the mixing water if, due to high temperature, low slump, flash set or cold joints are encountered.

Other precautions recommended by ACI Standard 305-72 shall also be adopted.

## **6. TEST OF CONCRETE QUALITY**

- 6.1 The Contractor shall provide samples of concrete for testing at the Supervisor's direction. Proper facilities shall be provided for making and curing the test specimens in accordance with PS 560 and PS 849. A competent person shall be employed by the Contractor whose first duty shall be to supervise all stages in the preparation and placing of the concrete. All test specimens shall be made and site tests carried out under his direct supervision.
- 6.2 Preliminary cube tests and works cube test shall be performed in accordance with PS 560 and PS 849 at the discretion of the Supervisor. Works transverse tests shall be performed in accordance with sub-clauses 208 c and 610 d of CP 114. The standard of acceptance for preliminary and works tests shall be as given below.
- 6.3 The usual test for concrete with maximum size of aggregate up to 4 cm inch is the 15 cm cube tested in compression. Details of making and curing compression test cubes are given in BS 1881 and details of the testing are given in Part 8 of BS 1881.
- 6.4 For all grades of concrete, preliminary cube strength test with the mixes and materials to be used shall be performed in accordance with PS 560, PS 849 and BS 1881 before the work is begun and subsequently whenever any change is to be made in the materials or in the proportions of materials to be used, or as required by the Supervisor. The strengths shall comply with the standard of quality specified in accordance with Table 1 for preliminary tests. The cost of such testing shall be borne by the Contractor.
- 6.5 Test sample shall be taken at the mixer or as directed by the Supervisor. The test specimens shall be cured in accordance with PS 560, PS 849 and BS 1881.
- Records shall be kept of all test cubes identifying the mix used the section of work for which the concrete was used and the date poured.
- 6.6 Five test cubes are to be tested for compressive strength as specified in BS 1881. These tests shall be carried out at site or in a laboratory approved by the Supervisor. Two cubes shall be tested at the age of seven days and three at 28 days and the strengths determined are to comply with the standard of quality specified. The laboratory tests shall be carried out by an independent organization, such as Government Testing Laboratory or such other undertakings approved by the Supervisor. The original test reports received from the above authorities should be submitted to the Supervisor.
- 6.7 For all grades of concrete, the appropriate strength requirement shall be considered to be satisfied if none of the strengths of the cubes is below the specified cube strength or if the average strength of the three cubes is not less than the specified cube strength and the difference between the greatest and the least strength is not more than 20% of the average.
- 6.8 When the results of works cube tests show that the strength of any concrete is below the minimum specified, the Supervisor may give instructions for the whole or part of the work concerned to be removed and replaced at the expense of the Contractor. The Contractor shall bear the cost of any other part of his, or any other contractor's work, which has to

be removed and replaced as a result of the defective concrete. If any concrete is held to have failed, the Supervisor may order the proportions of that class of concrete to be changed in order to provide the specified strength.



## 7. FINISHING OF FORMED SURFACES

### 7.1 General

- 7.1.1 After removal of forms, the surfaces of concrete shall be given one or more of the finishes specified below in locations designated by the Contract Documents.
- 7.1.2 When finishing is required to match a small sample furnished to the Contractor, the sample finish shall be reproduced on an area at least 9.3 Sqm. in an inconspicuous location designated by the Supervisor before proceeding with the finish in the specified location.
- 7.1.3 Allowable deviations from plumb or level and from the alignment profile grades and dimensions are specified in clause 9. Tolerances for concrete construction and defined as tolerances that are to be distinguished from irregularities in finish as described herein. The finish requirements for concrete surfaces shall be as generally specified in this clause and as indicated on the Drawings. Finishing of concrete surfaces shall be performed only by workmen who are skilled in concrete finishes. The Contractor shall keep the Supervisor advised as to when finishing of concrete will be performed. Unless inspection is waived in each specific case, finishing of concrete shall be performed only in the presence of the Supervisor. Concrete surfaces will be tested by the Supervisor where necessary to determine whether surface irregularities are within the limits herein after specified. Surface irregularities are classified as abrupt or gradual.

Offsets caused by displaced or misplaced form sheeting or lining or sections, or otherwise defective form lumber will be considered as abrupt irregularities, and will be tested by direct measurements. All other irregularities will be considered as gradual irregularities, and will be tested by use of a template, consisting of a straight edge or the equivalent thereof for curved surfaces. The length of the template will be 2 m. for testing of formed surfaces and 3 m. for testing of unformed surfaces.

### 7.2 As-cast Finishes

Unless otherwise specified or indicated on the Drawings the classes of finish shall apply as follows:

#### 7.2.1 Rough form finish:

No selected form facing materials shall be specified for rough form finish surfaces. Tie holes and defects shall be patched. Fins exceeding 6 mm height shall be chipped off or rubbed off. Otherwise, surfaces shall be left with the texture imparted by the forms.

#### 7.2.2 Fair face finish:

Fair face finish applies to concrete formed surfaces, the appearance of which is considered by the Supervisor to be of special importance, such as surfaces of structures prominently exposed to public inspection. Surfaces of concrete structures requiring fair face finish is shown in the Drawings. Surface irregularities, measured as described in sub-clause 7.2.1, 'Rough form finish', shall not exceed 1/4 inch for gradual irregularities and 3 mm for abrupt irregularities, except that abrupt irregularities will not be permitted at construction joints. Abrupt irregularities at construction joints and elsewhere in excess of 3 mm and gradual irregularities in excess of 6 mm shall be reduced by grinding so

as to conform to the specified limits. Abrupt irregularities at construction joints shall be ground on level of 1 to 20 ratio of height to length.

Unless otherwise approved, repair of imperfections in formed concrete shall be completed within 24 hours after removal of forms. The form facing material shall produce a smooth, hard, uniform texture on the concrete. It may be plywood, temperate concrete-form-grade hardboard, metal, plastic paper, or other approved material capable of producing the desired fair face finish. The arrangement of the facing material shall be orderly and symmetrical, with the number of seams kept to the practical minimum. It shall be supported by studs or other backing capable of preventing excessive deflection. Material with raised grain, torn surfaces, worn edge, patches, dents, or other defects which will impair the texture of the concrete surface shall not be used. Tie holes and defects shall be patched. All fins shall be completely removed.

### 7.2.3 Architectural Finish Concrete:

Architectural finish to concrete formed surfaces as shown on the Drawings is required by the Supervisor where the architectural appearance of surfaces of structures exposed to public view is of special consideration and importance. The Contractor shall use approved special material for formwork and design the forms in conformity with the specified architectural patterns, textures and finishes in order to obtain first class architectural finish on formed concrete surface without any defect, irregularities, blemishes, imperfections and encrustation's.

#### Samples:

1. Submit to the Supervisor a minimum of two units or portions of units of each precast item required. Each pair of samples when accepted will describe the allowable limits between which variations can be acceptable.
2. Similar samples of in-situ concrete for approval by the Supervisor submit two samples, 0.2 Sqm. of each type of exposed in-situ concrete. All in-situ samples will remain at the construction site.

#### Sample approvals of precast & in-situ concrete:

These samples will be reviewed and approved on the basis of colour, dimensional accuracy, and finish of surfaces and general appearance. The same requirements for sample approval will be required for both precast and in-situ concrete exposed surfaces.

#### Forms:

The contractor must maintain the forms unusually tight and braces to prevent movement, mal-alignment and bleeding that will result in sand streaks, honeycomb, fins, stain or unsightly appearance.

If wood forms are chosen to be used by the Contractor they shall be constructed of 2 cm minimum thickness plywood constructed in a fashion to allow many re-uses with all surfaces sealed with a polyurethane varnish.

Edges, surfaces and corners of forms shall be sealed to prevent loss of any matrix or unequal absorption of water. Corners of wood forms shall be filled with suitable compound and all contact surfaces sealed with a polyurethane varnish.

Re-use of forms shall be subject to approval by the Supervisor.

Curing:

Curing shall be done in shade (out of direct sunlight) and shall be for a minimum period of 4 days.

Finishing procedures:

"Finishing procedures for filling air void in smooth finished concrete developed by a formed surface":

While the concrete surface is still damp (not more than three days after removal of forms), apply a thin coat of medium consistency neat cement slurry by means of bristle brushes to provide a bonding coat within any pits or blemishes in the parent concrete; avoid coating large areas of the finished surface. Before slurry has dried or changed colour, apply a dry (almost crumbly) grout comprised of one part cement, of the type and brand of cement used in the original concrete, to one and one-half parts clean masonry sand with a fineness modulus of approximately 2.25 and complying with the gradation requirements of the ASTM Specifications C 144. Mix proper amounts of white cement and colouring with the parent mortar to produce a satisfactory colour match with the parent concrete after hardening. Use samples previously prepared.

Apply the finishing grout uniformly with damp (neither dripping wet nor dry) pads of coarse burlap approximately 6 inch square used as a float. Scrub the grout well into the pits to provide a dense mortar in all the imperfections to be filled. Allow the mortar to partially harden, from one to two hours, depending upon the weather. Avoid direct hot sunlight. If the air is hot and dry, keep the concrete surface damp during this period using a fine fog spray. When the grout has hardened sufficiently so it can be scraped from the surface with the edge of a steel trowel without damaging the grout from the small pits or holes, cut off all that can be removed with a trowel without delay; next allow the surface to dry thoroughly and rub it vigorously with clean, dry burlap to completely remove any dried grout. No visible film of grout shall remain after this rubbing. Complete the entire cleaning and grouting operation for the grout to dry after it has been cut with the trowel, so it can be wiped off clean with the burlap.

On the day after the repair work, the concrete surfaces should again be wiped off clean with dry burlap to remove any inadvertent dust; leave no built-up surfaces on the parent surfaces. Employ, if possible, a used piece of burlap containing old hardened mortar to act as a mild abrasive. Use of fine abrasive stone if needed to remove any remaining built-up film without breaking through the surface film of the original concrete. Such scrubbing should be light and sufficient only to remove excess material without working up a lather of mortar or changing the texture of concrete.

Following the final bagging or stoning operation, provide a thorough wash down with stiff bristle brushes to remove all extraneous materials and spray the

concrete surface with a fine fog spray periodically to maintain a continually damp condition for at least three days after application of the pit repair grout.

Rust Stains:

All rust stains are to be removed employing the following procedure:

The rust stain shall be soaked for 10 minutes with a solution of 50 mg. of sodium citrate in 150 mg. water (brushing the solution at short intervals is satisfactory). Then the surface is sprinkled with crystals of sodium hydrosulphite and covered with a paste of Fuller's Earth and water. On a vertical surface, the paste is applied with a trowel, with the crystals first sprinkled on the paste so they will be in direct contact with the stain. The paste is allowed to dry for 10 minutes then scraped off and the treatment repeated if necessary.

Repairing of Formed Surfaces:

It is the intention of Specification to require form mixture of concrete and workmanship so that concrete surfaces, when exposed, will require no patching. Any concrete which is not formed as required and conforming to approved samples or for any reason is out of alignment or level or shows a defective surface, shall be removed from the job by the Contractor at his expense unless the Supervisor grants permission to repair the defective area. Permission to patch any such area shall not be considered a waiver of the Supervisor's right to require a complete removal of defective work if the repair does not, in his opinion, satisfactorily restore the quality and appearance of the surface. The Supervisor shall be the sole judge of acceptability of appearance.

7.3 **Finishes of Unformed Surfaces:**

7.3.1 **Monolithic Concrete Floor Finish'**

Where monolithic concrete floor finish is shown on the Drawings, placing shall proceed continuously for the full thickness of the course or RCC slab without change in concrete mix. Mixing water shall be the minimum required for proper placing, and will be as specified by the Supervisor. After placing, floors, and other surfaces shall be floated with a wood float to a true surface and to elevation as shown on the Drawings. Where indicated on the Drawings, floor surfaces shall be steel trowel finished. Trowelling shall be the minimum amount consistent with maintaining a smooth dense surface, and shall not be done until the mortar has hardened sufficiently, to prevent excess fine material from being worked to the surface, and shall produce a dense uniform surface, free from blemishes and trowel marks.

Gradual surface irregularities shall not exceed 1/16 inch. The addition of water, dry cement, or dry cement mortar, to the surface of the concrete to facilitate finishing will not be permitted.

7.3.2 **Equipment Foundations'**

Unless otherwise specified, exposed, surfaces of equipment foundations shall be given steel trowel finish to produce a surface similar to the specified concrete floor finish.

**8. REPAIR OF SURFACE DEFECTS**

8.1 **General**

- 8.1.1 Any concrete failing to meet the specified strength or not formed as shown on drawings, concrete out of alignment, concrete with surfaces beyond required tolerances or with defective surfaces which cannot be properly repaired or patched in the opinion of the Supervisor shall be removed at Contractor's cost. The Supervisor may reject any defective concrete and order it to be cut out in part or in whole and replaced at the Contractor's expense.
- 8.1.2 All ties and bolt holes and all repairable defective areas shall be patched immediately after form removal.

## 8.2 **Repair of Defective Areas**

- 8.2.1 All honeycombed and other defective concrete shall be removed down to sound concrete. The area to be patched and an area at least 6 inch wide surrounding it shall be dampened to prevent absorption of water from the patching mortar. A bonding grout shall be prepared using a mix of approximately 1 part cement to 1 part fine sand passing No.25 BS Sieve and shall then be well brushed into the surface.
- 8.2.2 The patching mixture shall be made of the same material and of approximately the same proportions as used for the concrete, except that the coarse aggregate shall be omitted and the mortar shall consist of not more than 1 part cement to 2-1/2 parts sand by damp loose volume. White Portland cement shall be substituted for a part of the gray Portland cement on exposed concrete in order to produce a colour matching the colour of the surrounding concrete, as determined by a trial patch.
- 8.2.3 The quantity of mixing water shall be no more than necessary for handling and placing. The patching mortar shall be mixed in advance and allowed to stand with frequent manipulation with a trowel, without addition of water, until it has reached the stiffest consistency that will permit placing.
- 8.2.4 After surface water has evaporated from the area to be patched, the bond coat shall be well brushed into the surface. When the bond coat begins to lose the water sheen, the premixed patching mortar shall be applied. The mortar shall be thoroughly consolidated into place and struck off so as to leave the patch slightly higher than the surrounding surface. To permit initial shrinkage, it shall be left undisturbed for at least 1 hour before being finally finished. The patched area shall be kept damp for 7 days. Metal tools shall not be used in finishing a patch in a formed wall, which will be exposed.
- 8.2.5 Where as-cast finishes are specified, the quantity of patched area shall be strictly limited. The combined total of patched areas in as-cast surfaces shall not exceed 0.2 sqm. in each 95 sqm. of as-cast surface. This is in addition to form tie patches, if the project design permits ties to fall within as-cast areas.
- 8.2.6 Any patches in as-cast architectural concrete shall be indistinguishable from surrounding surfaces. The mix formula for patching mortar shall be determined by trial to obtain a good colour match with the concrete when both patch and concrete are cured and dry. After initial set, surfaces of patches shall be dressed manually to obtain the same texture as surrounding surfaces.

8.2.7 Patches in architectural concrete surfaces shall be cured for 7 days. Patches shall be protected from premature drying to the same extent as the body of the concrete.

8.3 **Tie and Bolt Holes**

After being cleaned and thoroughly dampened, the tie and bolt holes shall be filled solid with patching mortar. If architectural appearance requires, these holes may be filled partially creating the desired round clear holes pattern on surfaces exposed to view.

8.4 **Proprietary Materials**

If permitted or required by the Supervisor, proprietary compounds for adhesion or as patching ingredients may be used in lieu of or in addition to the foregoing patching procedures. Such compounds shall be used in accordance with the manufacturer's recommendations with prior approval of the Supervisor.

**9. CONCRETE CONSTRUCTION TOLERANCES**

Where tolerances are not stated in the specifications or drawings for any individual structure or feature thereof, maximum permissible deviations from established lines, grades and dimensions shall conform to the following. The Contractor is expected to set and maintain concrete forms so as to ensure complete work within tolerance limits. These allowable tolerances shall not relieve the Contractor of this responsibility for correct fitting of indicated materials. These tolerances are not cumulative.

9.1 Variation from the plumb (or the specified batter for inclined walls.)

9.1.1 In the lines and surfaces of columns, piers, and walls:

In any 3 m of length or height	6 mm
In any storey or 6 m length	9.5 mm
Maximum for the entire length or height.	25 mm

9.1.2 For exposed corner columns, control joint grooves and other conspicuous lines.

In any bay or 6 m maximum	6 mm
Maximum for the entire length or height	12 mm

9.2 Variation from the level or from the grades indicated on the drawings.

9.2.1 In floors, ceilings, beams soffits and in rises measured before removal of supporting shores.

In any 3 m of length	6 mm
In any bay or in any 6 m length	9.5 mm
Maximum for the entire length	20 mm

9.2.2 For exposed lintels, sills, parapets, horizontal grooves and other conspicuous lines.

	In any bay or 6 m length	6 mm
	Maximum for the entire length	12 mm
9.3	Variation of the linear building lines from established position in plan and related position of columns, walls and partitions.	
	In any bay or 6 m of length	12 mm
	Maximum for the entire length	25 mm
9.4	Variation in the sizes and locations of sleeves, floor openings and wall openings. $\pm 6$ mm	
9.5	Variation in cross-sectional dimensions of columns and beams and in the thickness of slabs and walls.	
	Minus	6 mm
	Plus	12 mm
9.6	<b><u>Footings</u></b>	
9.6.1	Variation in dimensions in plan	
	Minus	12 mm
	Plus (plus variation applied to concrete only, not to reinforcing bars or dowels). 50 mm	
9.6.2	Misplacement or eccentricity	
	2 percent of the footing width in the direction of misplacement but not more than (applies to concrete only, not to reinforcing bars or dowels). 50 mm	
9.6.3	Thickness	
	Decrease in specified thickness	5%
	Increase in specified thickness	No limit
9.7	<b>Variation in Steps</b>	
9.7.1	In a flight of stairs	
	Rise	$\pm 3$ mm
	Tread	$\pm 6$ mm
9.7.2	In consecutive steps	
	Rise	$\pm 2$ mm
	Tread	$\pm 3$ mm
9.8	<b><u>'Tolerances for Precast concrete construction'</u></b>	

Forms must be true to size and dimensions of concrete members shown on the plans and be so constructed that the dimensions of the finished products will be within the following limits at the time of placement of these units in the structure, unless otherwise noted on structural-architectural drawings:

9.8.1 Overall dimensions of members 1.5 mm per 3 m.

9.8.2 Cross-sectional dimensions  
Sections less than 8 cm. 1.5 mm  
Sections over 8 cm and less than 46 cm . 3 mm  
Sections over 46 cm. 6 mm

9.8.3 Deviations from straight line long sections.

Not more than 3 mm per 3 m.

9.8.4 Deviation from specified camber  $\pm 1.5$  mm per 3 m span.

Maximum differential between adjacent units in erected position 6 mm.

## 10. ACCEPTANCE OF STRUCTURE

### 10.1 General

10.1.1 Completed concrete work which meets all applicable requirements will be accepted subject to the other terms of the Contract Documents.

10.1.2 Completed concrete work which fails to meet one or more of the requirements and which has been repaired to bring it into compliance will be accepted subject to the other terms of the Contract Documents.

10.1.3 Completed concrete work which fails to meet one or more of the requirements and which cannot be brought into compliance may be accepted or rejected as provided in these Specifications or in the Contract Documents. In this event, modifications may be required to assure that remaining work complies with the requirements.

### 10.2 Dimensional Tolerances

10.2.1 Formed surfaces resulting in concrete outlines smaller than permitted by the tolerances of clause 9 shall be considered potentially deficient in strength and subject to the provisions of sub clause 10.4.

10.2.2 Formed surfaces resulting in concrete outlines larger than permitted by the tolerances of clause 9 may be rejected and the excess material shall be subject to removal. If removal of the excess material is permitted, it shall be accomplished in such a manner as to maintain the strength of the section and to meet all other applicable requirements of function and appearance. Permission is required if excess material is to be removed in accordance with this clause.

10.2.3 Concrete members cast in the wrong location may be rejected if the strength, appearance or function of the structure is adversely affected or if misplaced items interfere with other construction.



10.2.4 Inaccurately formed concrete surfaces exceeding the limits of Clause 9 or of Clause 5.6 of Section 'Formwork' and which are exposed to view, may be rejected and shall be repaired or removed and replaced if required.

10.3 **Appearance**

10.3.1 Architectural concrete with surface defects exceeding the limitations of Sub-clause 5.6 of Clause 5 of the Section, 'Formwork' shall be removed and replaced.

10.3.2 Other concrete exposed to view with defects which adversely affect the appearance of the specified finish may be repaired only by approved methods.

10.3.3 Concrete not exposed to view is not subject to rejection for defective appearance.

10.4 **Strength of Structure**

10.4.1 The strength of the structure in place will be considered potentially deficient if it fails to comply with any requirements, which control the strength of the structure, including but not necessarily limited to the following conditions.

- Concrete strength requirements not considered to be satisfied in accordance with Clause 6 hereof.
- Reinforcing steel size, quantity, strength, position or arrangement at variance with the requirements as listed under specification of 'Reinforcement' or in the Contract Documents.
- Concrete which differs from the required dimensions or location in such a manner as to reduce the strength.
- Curing less than that specified.
- Inadequate protection of concrete from extremes of temperature during early stages of hardening and strength development.
- Mechanical injury, construction fires, accidents of premature removal of formwork likely to result in deficient strength.
- Poor workmanship likely to result in deficient strength.

10.4.2 Structural analysis and/or additional testing may be required when the strength of the structure is considered potentially deficient.

10.4.3 Core tests may be required when the strength of the concrete in place is considered potentially deficient.

10.4.4 If core tests are inconclusive or impractical to obtain or if structural analysis does not confirm the safety of the structure, load tests may be required and their result evaluated in accordance with British Standard BS 8110 or ACI Standard 318.

10.4.5 Concrete work judged inadequate by structural analysis or by results of a load test shall be reinforced with additional construction if so directed by the Supervisor or shall be replaced, at the Contractor's expense.

10.4.6 The Contractor shall pay all costs incurred in providing the additional testing and/or analysis required by this section.

10.4.7 The Employer will pay all costs of additional testing and/or analysis which is made at his request and which is not required by these Specifications, or by the Contract Documents.

## **11. PVC WATER STOP/HYDROFOIL**

### **11.1 Material**

All PVC water stops/hydrofoil shall be central bulb type from a manufacturer approved by the 'Supervisor'. The specific gravity of PVC water stop/hydrofoil shall not be less than 1.37 and Full stretch Break cut intensity when tested at normal temperature shall not be less than 129 MPa.

The material shall have a modulus of rigidity of 58 MPa at +10° C and 10,500 psi at 20° C.

### **11.2 Placing & Connections**

In general all PVC water stops/hydrofoil shall be placed in the centre of the structural member. Each piece of the water stop-hydrofoil shall be of maximum practicable length. An ordinary sharp knife saw or any other sharp tool can be used to cut the water stop. Joints at inter sections and at ends of pieces shall be made in the manner most appropriate to the material being used. Joints shall develop effective water tightness fully equal to that of the continuous water stop material and shall permanently retain their flexibility. For straight line connection-melting method of connection can be used by passing two water stops intended for connection against a heated iron or copper sheet. When they are melted, the two are combined.

After joining, the water stop should be allowed to cool.

For all other connections such as T-type or L-type, the welding method of joining should be used. Welding rod of same material as the water stop shall be used. The welding rod & the water stop shall be heated & melt at the same time, by means of heated air jetting from the hot jet gun.

## **12. NON-SHRINK GROUT:**

Grout for placement under base and bearing plates of machinery and equipment, for grouting anchor bars and dowels and for similar uses shall be as follows:-

### **12.1 Composition**

12.1.1 Non-shrink grout of less than 25 mm thickness shall consist of one part Portland cement and one part of clean sharp sand conforming to the requirements of these specifications and 1:22,000 to 1:15000 part of grained aluminium powder containing non polishing agent.

12.1.2 Non-shrink grout of 25 mm or more in thickness shall be proportioned as above except that 1-1/2 parts of 9.5 mm to 6 mm pea gravel shall be added.

12.1.3 The above-specified composition may be varied if required by the Supervisor. The Contractor shall, at his own cost, make optimum mix design and testing for approval of the composition.

12.1.4 Proportioning shall be done by weight.

12.1.5 Mixing water shall be proportioned so as to provide a flowable mixture without segregation or bleeding. Dry packing will not be permitted.

12.2 **Application**

12.2.1 Concrete surfaces to receive non-shrinking grout shall be roughened, cleaned and dampened.

12.2.2 Form shall be provided to retain the grout until sufficiently hard to support itself.

12.2.3 Grout shall be poured in place and thoroughly rodded or washed to prevent the formation of voids.

12.2.4 After non-shrink grout has received its initial set, it shall be kept damp for 24 hours.

12.3 **Non-Shrink Second Stage Concrete Grout**

Non-shrink second stage concrete grout shall be provided and placed in position where shown on the Drawings or as directed by the Supervisor. Non-shrink concrete mix proportion shall be one part cement two parts coarse clean sand and four parts of coarse aggregates meeting the requirements of these specifications and 1:22,000 to 1:15000 part of grained aluminium powder containing non-polishing agent. Proportioning shall be done by weight.

The above specified composition may be varied if required by the Supervisor.

The Contractor shall at his own cost make optimum mix design and testing for approval of the Supervisor prior to commencement of the work.

Mixing water and application procedure shall be followed as given in sub-clause 12.2 or as per direction of the Supervisor.

13. **VAPOUR BARRIER**

Vapour barrier shall be polyethylene building film, visqueen standard or approved equal. The film shall be 150 micron thick (100 gauge). The quality of material shall be approved by the Supervisor prior to use in the works.

Vapour barrier shall be laid in position wherever shown on the Drawings.

The material shall be supplied in rolls and laid by rolling over the prepared surface at the levels and position in the areas shown on the Drawings. Where joint is necessary at the side or end of a sheet, this shall be a double weld folded joint made by placing the edges together and folding over twice continuously taking the top edge prior to concreting. The Contractor shall protect the film sheets from damages during laying and subsequent operations and shall replace at his own cost all damaged film sheets to the satisfaction of the Supervisor.

Manufacturer's recommendations and instructions along with the sample of material shall be submitted to the Supervisor for his approval.

14. **TESTING OF MATERIAL**

a) A site laboratory shall be established by the Contractor for all the required testing of concrete, aggregates and other materials etc. All tests shall preferably be done at site. Only the test which are not possible to be carried out in the site laboratory shall be referred to the laboratory approved by the Supervisor. All testing charges thereof shall be borne by the Contractor.

For testing of reinforcement steel bars, the samples shall be referred to the laboratory approved by the Supervisor at the cost of the Contractor.

- b) Cement shall be tested as prescribed in ASTM C -150.
- c) Aggregates shall be tested as prescribed in British Standard BS 812 & 882. In addition fine aggregate shall be tested for organic impurity in conformance with ASTM Standard C.40.

## 15. MEASUREMENT AND PAYMENT

### 15.1 General

Except otherwise specified herein or elsewhere in the Contract Documents, no measurement and payment will be made for the under mentioned specified works related to the relevant items of the Bills of Quantities. The cost thereof shall be deemed to have been included in the quoted unit rate of the respective items of the Bills of Quantities.

The rates quoted by the Contractor in the Bill of Quantities shall include work to be executed under these specification in any floor and at any height except where otherwise specifically stated in the relevant item of Bill of Quantities and the Contractor shall not be entitled to any claim or claim any compensation on this account.

15.1.1 Providing, fixing, striking, etc. of formwork.

15.1.2 Providing, placing and fixing of anchor bolts or any other embedded parts.

15.1.3 Providing and installing all type of joints in concrete structure, including expansion joints.

15.1.4 Providing and fixing water stoppers.

15.1.5 Transportation, lifting, launching and fixing in position of pre-cast elements.

15.1.6 Providing and filling of joints with Bitumen.

### 15.2 Plain and Reinforced Concrete

#### 15.2.1 Measurement

Concrete shall be measured as executed but no deduction shall be made for the following:

- Volume of any steel embedded in the concrete.
- Volume occupied by water pipes, conduits etc. not exceeding 65 square cm each in cross-sectional area.
- Voids not exceeding 26 square cm in work given in square feet. If any void exceeds 4 square inch, total void shall be deducted.

Voids, which are not to be deducted as specified above, refer only to openings or vents which, are wholly within the boundaries of measured areas. Openings or vents which are at the boundaries of measured areas shall always be subject to deductions irrespective of size.

Concrete work shall be classified and measured separately as listed under items of Bills of Quantities.

Junction between straight and curved works shall in all cases be deemed to be included with the work in which they occur.

Measurement of walls shall be taken between attached columns piers or pilaster. The thickness of attached columns, piers or pilaster shall be taken as the combined thickness of the wall and the columns, piers or pilaster.

Attached or isolated columns, piers, pilaster, and the like (except where caused by openings) having a length on plan not exceeding four times the thickness shall be classified as columns. Those having a length over four times the thickness and are caused by openings in wall shall be classified as walls.

Columns shall be measured from the top of footing/footing beams or floor surfaces to the underside of beams or slabs as the case maybe. Where the width of beams is less than the width of columns, the extra width at the junction shall be included in the beams.

The depth of the beams shall be measured from bottom of the slab to the bottom of the beams except in case of inverted beams where it shall be measured from top of slab to the top of beam. The cross-section of the beam shall be the actual cross-section below or above the slab.

Measurement of acceptably completed works of plain and reinforced cement concrete will be made on the basis of number of cubic meter concrete placed and compacted in position within the neat lines of the structure as shown on the Drawings or as directed by the Supervisor.

15.2.2 **Payment:** Payment will be made for the acceptable measured quantity of plain and reinforced cement concrete on the basis of unit rate per cubic meter quoted in the Bills of Quantities and shall constitute full compensation for all the works related to the item.

## **SECTION 2350 - PRECAST CONCRETE PAVERS**

### **01 SCOPE**

The Work under this section of specifications consists of furnishing all material, plant, labour, equipment, appliances and performing all operations in connection with supply and installation of precast concrete paver complete, in accordance with this section of specification and applicable drawing and/or as directed by the Supervisor.

### **02. SUBMITTALS**

The following submittals are required for approval of the Supervisor before installation of pre-cast concrete paver/block:

- Detail drawings and/or shop drawings
- Manufacturer's data/brochure
- Installation Manuals
- Test Reports
- Samples of the sizes shown on the contract drawings

03 **MATERIAL**

**3.1 Pavers**

The materials for pre-cast concrete pavers/blocks shall conform to the requirement specified herein.

The average compressive strength of the pre-cast concrete pavers/blocks shall be over 483 MPa as specified in BS-6717 Part-I 1993 for the type and size of pre-cast concrete pavers/blocks as shown on the drawings.

**3.2 Sand**

The sand bed which shall be provided underneath the pre-cast concrete pavers/blocks shall conform to the requirement of the fine aggregate as specified in Section 2300.

**3 PLACING OF PAVERS**

**3.1 Inspection**

The Contractor shall examine the substrata, adjoining construction, and the conditions under which the work is to be installed. The Contractor shall not proceed with the work until unsatisfactory conditions have been corrected.

**4.2 Surface Preparation**

All dirt and loose material shall be removed from the substrata immediately before filling sand for bed.

The precast paver/blocks shall be placed on the bedding material true to the line and grade as shown on the plans. The joints shall be left open.

**4.3 Cutting and Fitting**

The pavers shall be cut neatly to line or precast sizes as required to complete the patterns shown and to fit against other work with uniform joints and edges as shown on drawing where not otherwise shown at such fittings.

**4.4 Installation**

Damping: The Contractor shall ensure that pavers and substrata are damp at time of laying pavers, but have no free water on their surfaces.

Laying: Pavers shall be laid in a full, uniform bed of sand, continuous and free from voids. Pavers shall be laid with joint spacing shown, in patterns as shown, tamped into position with top surfaces in true, uniform planes to the grades shown and as necessary to provide proper drainage, free from depressions which would cause puddles. After installing the concrete pavers in position, a layer of sand approx 1 to 2 cm shall be spread on top. A vibrating plate compactor will move over the pavers (2 to 3 times) so that the pavers and sand are in compact and stable position. Any residual points shall be filled by brushing sand into them. The excess sand shall be removed.

**4.5 Replacement, Protection and Cleaning**

Replacement: All defective work shall be replaced, as directed by the Supervisor including cracked, chipped, and stained pavers.

Protection: The work shall be protected from damage until acceptance. When construction traffic is permitted, maintain pavers as clean as possible by removing surface stains and spillage of materials as they occur.

Final Cleaning: Concrete pavers shall be swept and washed free of stains, discolorations, dirt, and other foreign material just prior to final inspection.

## 5. MEASUREMENT AND PAYMENT

### 5.1 General

Except otherwise specified herein or elsewhere in the Contract Documents, no measurement and payment will be made for the under mentioned specified works related to the relevant items of the Bill of Quantities. The cost thereof shall be deemed to have been included in the quoted unit rate of the respective items of the Bill of Quantities.

- 5.1.1 Providing, fixing, striking etc. of formwork.
- 5.1.2 Curing and testing of concrete.
- 5.1.3 Sand cushion in bed/joints.
- 5.1.4 Concrete to stabilize edge pavers.
- 5.1.5 Compaction and consolidation of newly laid surface.
- 5.1.6 Temporary storage of pavers and re-handling.
- 5.1.7 Preparation of sub grade with compaction
- 5.1.8 Any Wastage
- 5.1.9 Cement sand mortar for laying/joining.

### 5.2 Pre-Cast Concrete Pavers/Blocks

#### 5.2.1 Measurement

Measurement of acceptably completed works of pre-cast concrete pavers/blocks will be made on the basis of actual area in square meter of concrete pavers/blocks provided and laid in position to the line, level and grade as shown on drawing or as directed by the Supervisor.

#### 5.2.2 Payment

Payment will be made for acceptable measured quantity of pre-cast concrete pavers on the basis of unit rate per square meter quoted in the Bill of Quantities and shall constitute full compensation for all the works related to the item.

## SECTION 3000 - STRUCTURAL STEEL WORKS

### 1. SCOPE

The work covered by this section, consists of supply of all material, labour, plant, equipment and appliances including welding, bolts, nuts, washers, anchor bolts, embedded parts etc, fabrication, erection and painting in accordance with the specifications and as per drawings and as directed by the Supervisor.

2. DRAWINGS

Design drawings shall be prepared by the Supervisor and supplied to the Contractor. These shall contain main dimensions, sizes of members, typical details of joints.

Workshop drawings shall then be prepared by the Contractor from the design drawings supplied and submitted to the Supervisor for approval.

3. MATERIAL

Except otherwise stated in the drawings, the material specifications shall conform to the following. Wherever necessary the Contractor may use equivalent alternative material subject to approval of the Supervisor.

3.1 Structural Steel

Structural steel for structures shall conform to the requirements of ASTM A-615 or equivalent

3.2 Steel Forging

Steel forgings shall conform to the requirements of ASTM A235.

3.3 Steel Casting

Steel casting shall conform to the requirements of ASTM A27.

3.4 Welding

Welding Electrodes for manual shielded metal arc welding shall conform to AWS A 5.1 latest edition or the A 5.5 latest edition. Equivalent locally manufactured electrodes may be used subject to the approval of the Supervisor.

3.5 Common Bolts, Anchor Bolts, Nuts, Washers and Bolts shall conform to the requirements of ASTM A 307.

3.6 High Strength Bolts

High strength carbon steel bolts including nuts and washers shall conform to the requirements of ASTM A325 latest editions and of AISI B18.2

3.7 Washers

Cut Washers : Shall be of structural grade steel and shall conform to the dimension of the manufacturer's regular standard for plain washers for the size of bolts used.

3.8 Cast Iron

Shall conform to the requirements of latest edition of ASTM A 48.

4. FABRICATION

The Contractor shall notify the Supervisor about any problems or doubts/errors discovered in the drawings for clarification/rectification well in time to prevent any fabrication errors. Fabrication shall not be commenced until approval has been obtained from the Supervisor.

4.1 Straightening of Material

Rolled material, before being worked upon must be straightened within tolerances by ASTM specifications A6 Straightening, necessarily shall be done by mechanical means or by the application of a limited amount of localized heat. The temperature of heated areas, as measured by approved methods, shall not exceed 1100°F for A 514 steel or 1200°F for other steels.

4.2 Cutting



As far as possible cutting must be done by shearing. Oxygen cutting shall be done where shear cutting is not possible and shall preferably be done by Machine. All edges shall be free from gauges, notches or burs. If necessary the same shall be removed by grinding.

4.3 Holes Punching Drilling.

Holes shall be punched where thickness of the material is not greater than the diameter of bolt + 1/8". Where the thickness of the material is greater the holes shall either be drilled or sub-punched and reamed to size. The die for all sub-punched holes and the drill to all sub-drilled holes shall be at least 1/16" smaller than the nominal diameter of the rivet or bolt. Holes for A514 steel plates over 1/2" thick shall be drilled.

4.4 Welding

4.4.1 General:

The execution and inspection of welding will be done in accordance with the provisions of the American welding society code for welding in Building construction, D1.0. No welding for piping/electrical supports shall be made transversely to any tension flanges of trusses, beams or columns.

4.4.2 Automatic sub-merged Arc Welding:

For all built-up members, i.e. sections fabricated from plates and flat bars or compound rolled sections, plate and box girders, where long continuous, welding is to be done, should be executed by Automatic submerged Arc Welding process in accordance with relevant AWS specifications.

4.4.3 Maximum and minimum size and lengths of fillet welds shall be in accordance with AISC specifications.

Surface to be welded shall be free from loose scale, slag, rust, grease, paint or any other foreign matter except mill scale which withstands vigorous wire brushing.

4.5 Tolerances

A variation of 1 mm is permissible in the overall length of members with both ends finished for Contact bearing. The bearing surfaces prepared to a common plane by milling.

Members without end finished for contact bearing which are to be framed to other steel parts of the structure shall have a variation from detailed length not greater than 1/8".

5. SURFACE PREPARATION/PAINTING

5.1 Surface Preparation

a) All structural steel material i.e. rolled steel sections, plates, pipes, flat bars; chequered plates shall be cleaned free from loose scale, rust, burrs slag, etc. by means of sand blasting.

5.2 Painting

a) Immediately after surface preparation all material shall be given one prime coat of rust preventive paint.

- b) After fabrication one shop coat of prime paint and then one coat of enamel paint shall be applied.
- c) One final coat of enamel paint shall be applied after erection of all components.
- d) The type of primer and enamel paints to be applied shall be as specified on the drawings.
- e) All other requirements for the specified paint system shall be in accordance with the paint manufacturer's specification / recommendations.
- f) The Contractor shall use the best quality of the type of paint specified and shall get the same approved by the Supervisor.
- g) Steel work/Surfaces not to be painted
  - i) Steel work to be encased/embedded in concrete or surface in contact with concrete or grout shall not be painted, but shall be given a cement wash after sand blasting.
  - ii) Machined finished surfaces shall not be painted but shall be coated with rust preventive compound, (approved by the Supervisor) immediately after finishing. Such surfaces shall also be protected with wooden pads or other suitable means for transportation. Unassembled pins, keys, and bolt thread shall be greased and wrapped with moisture resistant paper.

## 6. INSPECTION AND TESTS

- 6.1 Manufacturer's Work Test Certificate for all material used shall be furnished by the contractor for Supervisor's scrutiny and approval.
- 6.2 Rolling tolerance of all shapes and profile according to AISC shall be in accordance with the provisions of the American Society for Testing and Materials Designation A.6. These shall be checked by the Contractor before being worked upon and shall be rejected if found not within limits.
- 6.3 The Contractor shall arrange for analysis and test of all material rolled locally at a testing laboratory selected by the Supervisor.
- 6.4 Inspection of Welding.  
  
The inspection of welding shall be performed in accordance with the American Welding Society specifications, as directed by the Supervisor.
- 6.5 Rejection  
  
Materials or workmanship not in reasonable conformance with the provisions of these specifications shall be rejected at any time during the progress of the work or the completion and erection at site.

## 7. MISCELLANEOUS STEEL WORKS

### 7.1 General

The work covered shall include furnishing, fabricating, installing and painting miscellaneous steel work including the following:

- Steel louvered doors
- Steel rollup shutter
  
- G.I. Flashing
- Steel Fencing Grill
  
- Steel pipe Handrail

Drawing, material, fabrication, surface preparation shall conform to the applicable requirements of relevant clauses of these specifications. Any proposed deviation due to field conditions and availability of local material shall be submitted to the Supervisor for approval.

### 7.2 Steel louvered doors

Frame of steel louvered doors shall be fabricated from 16 SWG mild steel pressed sheets. The louvers shall be fabricated from 16 SWG MS sheets of design and spacing as shown on drawings and as per the approval of the Supervisor. Accessories such as hinges, locking arrangement, anchors, bolts, etc. shall be heavy duty. All exposed steel surface shall be painted with one coat of red oxide anti-rust paint and three coats of approved shade of enamel paint.

### 7.3 Steel roll up shutters

Sample of the materials shall be submitted to the Supervisor for approval prior to fabrication. Frames shall be fabricated from M.S. U channels, guides, edge angles, T angles, tees, etc. as specified on the drawings and approved shop drawings and instructions of the Supervisor. Material shall conform to ASTM-A36.

Roll up Mechanism shall be in accordance with the approved shop drawings. The shutter shall be fabricated from 22 SWG GI Sheet as per details. The surface of all steel surfaces shall be prepared to receive enamel paint in accordance with Clause 5.1 & 5.2 above.

### 7.4 G.I. Flashing/Expansion Joint Cover

Flashing/Expansion Joint Cover complete with fixing arrangement shall be furnished and installed in accordance with the drawings. The material shall conform to the requirements of ASTM specifications. The flashing/Expansion Joint Cover shall be installed in first class workmen like manner. Connections to adjacent concrete/brick elements shall be made as per details given in the drawings and instructions of the Supervisor-Incharge.

### 7.5 Steel Handrail/Bumper rail

Steel pipe handrails consisting of posts, handrail, knee rails and toe rail shall be fabricated in suitable units having two posts or three posts in one unit with erection joints between handrail and knee rails. Handrails of platforms galleries etc. of considerable length may not be shop fabricated as complete units consisting of posts etc. In case of such handrails the posts may be fabricated of the required height having one end with necessary arrangement for fixing to the platform or floor beams etc. And other end shop prepared to take the top handrail. Top handrail, knee rail and toe rail

may be brought at site in stock length. The same may then be cut and welded at site. Locally manufactured pipes, M.S or G.I may be used for the hand railing. These shall however conform to the requirements of ASTM A 53-65 or shall be of equivalent requirements.

## 8. MEASUREMENT & PAYMENT

### 8.1 General

Except otherwise specified herein or elsewhere in the Contract Documents, no measurement and payment will be made for the under mentioned specified works related to the relevant items of the Bill of Quantities. The cost there of shall be deemed to have been included in the quoted unit rate of the respective items of the Bill of Quantities.

The rates quoted by the Contractor in the Bill of Quantities shall include works to be executed under these specifications in any floor and at any height.

- 8.1.1 Nuts, bolts, screw, rivets, heads, fillets, welds welding rods, locks, rollers, rolling tracks etc.
- 8.1.2 Anti-corrosive prime coat.
- 8.1.3 Cleaning with sand blasting.
- 8.1.4 Painting/powder coating
- 8.1.5 Embedding/fixing of steel pipe hand rail / Bumper rail in concrete/ Block work.
- 8.1.6 All hardware in steel doors/rollup shutters including rolling mechanism, springs, GI cover sheets, locks, hold fasts, etc.
- 8.1.7 All metal embedded parts, metal fittings and fixtures required for the operational process.
- 8.1.8 Sealants for GI Flashing as specified.
- 8.1.9 Guide rails, edge angles, tees, etc. in rollup shutters.
- 8.1.10 Hinges, locking arrangement, Anchor, bolts etc. shall be heavy duty type.

### 8.2 M.S Grills

#### 8.2.1 Measurement

Measurement of acceptably completed works of M.S Grills will be made on the basis of net area in square meter of provided and fixed in position as shown on the drawing or directed by the Supervisor.

- 8.2.2 **Payment:** Payment will be made for acceptable measured quantity of MS Grills on the basis of unit rate per square meter quoted in the Bills of Quantities and shall constitute full compensation for all the works related to the item.

#### 8.3 Mild Steel Gate

- 8.3.1 Measurement: Measurement of acceptably completed works of M.S Gate will be made on the basis of net quantity in No. gate provided and fixed in position as shown on the drawing or directed by the Supervisor.

- 8.3.2 Payment: Payment will be made for acceptable measured quantity of MS Gate on the basis of unit rate per No. quoted in the Bills of Quantities and shall constitute full compensation for all the works related to the item.

### 8.4 M.S Decorative Fence

- 8.4.1 Measurement: Measurement of acceptably completed works of M.S decorative fence will be made on the basis of net area in square meter of provided and fixed in position as shown on the drawing or directed by the Supervisor.
- 8.4.2 Payment: Payment will be made for acceptable measured quantity of MS fence on the basis of unit rate per square meter quoted in the Bills of Quantities and shall constitute full compensation for all the works related to the item.

## **SECTION 3010 - STAINLESS STEEL MATERIAL & FINISHES**

### **1. SCOPE**

The requirement of this section applies to all stainless steel work which forms a part of the basic design and finish of the project, in particular the hand railing for the interior and exterior staircases. Certain major items are specified under other sections of these Specifications, in which case applicable portions of this section are included by reference.

Applicable portions of other sections of these Specifications are hereby included by reference to establish minimum quality standards and shall become a part of this section as if written out in full herein.

The work covered by this section, consists of supply of all material, labour, plant, equipment and appliances including welding, bolts, nuts, washers, anchor bolts, embedded parts etc, fabrication and erection in accordance with the specifications and as per drawings and as directed by the Supervisor.

### **2. TECHNICAL REQUIREMENTS**

#### **A. General**

- a) Provide units composed of brake formed shapes with visible portions of profile matching detail indicated on the drawings, and free from additional slots, grooves, fins or other.
- b) Fabricate and assemble all work in the shop wherever possible and otherwise pre-fit as required to reduce field fabrication to a minimum.

#### **B. Design**

Design anchors to allow for horizontal and vertical expansion. Screws, nuts, washers, bolts and reinforcement shall be aluminium, and of adequate strength for the proposed use.

#### **C. Appearance**

- a) Fit member neatly and to hairline accuracy with profile extending into joints without additional trim. Match flush joints to form perfectly smooth plane; match offset joints to hairline butt fit to flat surface beyond point of tangency of corner radius. Units using extra trim to conceal misalignment will not be acceptable.
- b) Make all connections by means of concealed fasteners; exposed fasteners will be permitted where essential. Use only countersunk Phillips flat head machine screws for exposed fasteners.
- c) Where additional strength of section is required to meet structural requirements, provide additional wall thickness or stiffeners inside the extrusion. Width of face (sight line) dimensions indicated on the drawings is maximum permissible exposed surfaces.
- d) Manufacturer's standard sections will be acceptable only when such extrusions are substantially in accordance with the profiles indicated on the drawings as accepted by the Supervising Supervisor.

#### **D. Packaging for Shipment**

Crates and wrapping as required. Material is accepted or rejected based on conditions as delivered to the job-site prior approvals notwithstanding.

### **3. SUBMITTALS**

A. Samples

Submit the following samples of materials and assemblies specified herein:

- a) Preliminary Approval Samples: All finishes.
- b) Product Samples: Hardware.
- c) Range Samples: All finishes.
- d) Test Samples: Upon request.

B. Shop Drawings

- a) Project Shop Drawings: All fabricated materials.

4. **SAMPLES**

A. Samples

Before any work is performed, the following samples shall be submitted:

- a) Representative samples of appropriate size of all stainless steel included in this work, to show final finished appearance.
- b) Representative samples of welded connections, mitred joint, and butt weld and typical brake form and bend for bar sheet stock to show final finished appearance.
- c) Representative samples of proposed mechanically fastened connections to show final assembled appearance.
- D. All samples shall be labelled to show material finish, thickness and specific use and location on work.
- E. For project reference, one set of record samples will be retained by the Supervising Supervisor, and kept available at the job site and one returned to the Contractor.

5. **SHOP DRAWINGS**

Submit shop drawings in accordance with General Conditions.

Coordinate shop drawings with material description to show location and extent of various finishes.

6. **MAINTENANCE INSTRUCTIONS**

Prepare and deliver to the Supervising Supervisor a complete maintenance manual.

Such documents are an integral part of the requirements of these Specifications and require close cooperation between the basic metal manufacturer, the fabricator and the finisher.

Maintenance information shall include specific instructions for:

- Routine cleaning instructions with recommendations for materials and schedule applicable to locality and exposure.
- Recommendations for major cleaning as required to maintain appearance.

Appropriate publications shall be included but these shall not be regarded as taking the place of required specific instructions.

## 7. MATERIALS

### A. Stainless Steel

- a) Materials not otherwise specified, in accordance with requirements of "Structural Steel Work".
- b) All Bar Stock including Shapes: Cold drawn AISI Type 1018 steel.
- c) Stainless Steel: ASTM A167 Type 302. Other 300 series stainless steels will be acceptable where required to suit specified fabrication requirements.

### B. Support Devices

- a) Reinforcement: Meet requirements of "Reinforcement" section.
- b) Fasteners used in assembling sections: Exactly matching adjacent surfaces where exposed or AISI 300 series stainless steel.
- c) Steel Anchors: Hot dip galvanized, or AISI 300 series.
- d) Inserts: For required anchorage into concrete or masonry work, furnish inserts of cast iron, malleable iron or 2.8 mm steel hot-dip galvanized after fabrication.
- e) Expansion Anchor Devices: Fed. Spec. FF-S-325 Group III, Type 4, Class 1, Int. Amendment 3: Molly "Parabolt" or equal.

### C. Paint for Ferrous Metal

Primer as follows: equivalent product manufactured by one of the approved manufacturers listed under "Painting and Finishing"; Fed. Spec. TT-P-86e, Type II, or "Tnemec" cement-in-oil type.

### D. Setting Grout

Rapid setting grout warranted by manufacturer to be compatible with aluminium; UPCO "Bostick 275"; similar by Steelcote. Grace or Acme Highway Products using less than full unit of powder so that mixture is pourable; or use L & M Crystex Grout. Metallic grout is not acceptable.

### E. Accessory Materials

- a) Joint Filler: Expanded cellular neoprene, closed cell, tape, coated with non-staining adhesive one surface; ASTM D 1056 "Testing Sponge and Expanded Cellular Rubber Products". Type SC-41: shape as required.
- b) Protective Coverings: After finishing procedures have been completed, apply protective wrappings of paper or plastic film. Keep material dry until wrappings are removed. Coatings, if used, must be completely removed

### F. Glass



For railing, 12mm thick tempered glass in panels shall be used with stainless steel balustrades. For further details of glass refer specification section 6250 i.e. Glazing.

**8. STAINLESS STEEL FINISHES**

Finish designations are indicated herein in accordance with the standards of the American Iron and Steel Institute.

**9. FABRICATION**

**A. General**

Comply with requirements of "Structural Steel Work", Section 3000.

**B. Welding and Grinding Stainless Steel**

- a) All welding shall be in accordance with appropriate recommendations of the American Welding Society and shall be done with electrodes and by methods recommended by the manufacturer of the alloys being welded. Type, size, and spacing of welds shall be as shown on approved shop drawings. All welds behind finished surfaces shall be so done as to minimize distortion or discolouration on the finished side. All weld spatter and welding oxides on finished surfaces shall be removed by descaling or grinding.
- b) Unless otherwise shown or specified, all weld beads on exposed polished surfaces shall be ground and polished to match and blend with finish on adjacent parent metal. Grinding and polishing shall be done only with clean wheels and other abrasives free from iron compounds.
- b) Thoroughly clean material after grinding or polishing to remove all contaminants which might affect appearance.

**10. PROTECTION AND CLEANING STAINLESS STEEL**

All work shall be protected from damage of any kind during handling, transportation and at the project site. All material shall be stored under waterproof cover on wood blocking or on suitable floors.

Finished surfaces shall be covered with protective paper, tape, or other approved strippable coating prior to shipment from the fabricator. Should construction schedules delay removal of protective strippable coating, periodic inspection at increasingly frequent intervals shall be made to be certain coating may be easily removed.

Upon completion, all exposed surfaces shall be thoroughly cleaned in accordance with the recommendations of the stainless steel producer.

## 11. MEASUREMENT & PAYMENT

### 11.1 General

Except otherwise specified herein or elsewhere in the Contract Documents, no measurement and payment will be made for the under mentioned specified works related to the relevant items of the Bill of Quantities. The cost thereof shall be deemed to have been included in the quoted unit rate of the respective items of the Bill of Quantities.

11.1.1 Providing nuts, bolts, screw, rivets, heads, fillets, welds and welding rods.

11.1.2 Galvanized and prime coating of paint.

11.1.3 Providing and installation of glazing in position.

11.1.4 All embedded parts unless otherwise specified in the Bill of Quantities.

11.1.4 Painting.

11.1.5 Master balustrades, grouting, pipes/bars etc.

11.1.6 Top rail of MS square pipe and Oak wood toping.

### 11.3 SS Hand Railing for Stairs

#### 11.3.1 Measurement

Measurement of acceptably completed works of SS railing will be made on the basis of actual length in running meter of railing provided, fabricated, erected and installed in position as shown on the drawings or as directed by the Supervisor.

#### 11.3.2 Payment

Payment will be made for acceptable measured quantity of SS railing on the basis of unit rate per running meter quoted in the Bill of Quantities and shall constitute full compensation for all the recovery related to the item.

## **SECTION 4200 – BRICK MASONRY**

### **1.0. SCOPE**

The work under this section of the specification consists of furnishing all plant, labour, equipment, appliances, and materials and in performing all operations in connection with supplying and constructing brick masonry, complete in strict accordance with this section of the specifications and applicable drawings and subject to the terms and conditions of the Contract. The scope of this section of specification is covered with detailed specification as laid down herein.

Exterior Brick Masonry walls are reinforced with steel. See Detail on drawings for this installation. Interior brick walls are no reinforced with steel.

### **2.0 APPLICABLE CODES AND STANDARDS**

Latest editions of the following ACI codes and ASTM Standards referred to herein, are applicable to these Specifications.

#### ACI Codes

ACI 530 Building Code Requirements for Masonry Structures

ACI 530.1 Specifications for Masonry Structures

#### ASTM Standards

ASTM C 62 Building Bricks (Solid Masonry units made from clay or shale)

ASTM C 216 Facing Bricks (Solid Masonry units made from clay or shale)

ASTM C 67 Sampling and Testing Bricks

ASTM C 270 Mortars for Unit Masonry

ASTM A 615 Deformed and plain billet bars for concrete reinforcement

### **3.0 SUBMITTALS**

#### **3.1 Manufacturer's Data**

Submit two copies of the manufacturer's specifications and other data for each type of brick and accessory required. Instructions shall be included for handling, storage, installation, and protection of units and accessories.

#### **3.2 Samples**

Submit three samples of each type of brick and accuracy required, also samples of the full range of exposed texture to be used in the completed work.

#### **3.3 Test Reports**

Reports for compressive strengths of brick and mortar; and tensile tests of reinforcing steel.

### 3.4 **Certificate of Compliance**

For Cement.

Reinforcing Steel (exterior walls only)

## 4.0 **MATERIALS**

### 4.1 **Cement & Aggregates**

All Portland cement shall conform to the requirements of ASTM C 150.

All aggregates for mortar shall conform to the requirements of ASTM C 144.

All water used in the manufacture of bricks and in the preparation of mortar shall be free from objectionable quantities of silt, organic matter, alkali, salts and other impurities. The water shall be tested in accordance with BS 3148, where directed by the Supervisor.

### 4.2 **Mortar**

Mortar shall conform to the requirements of ASTM C 270. Mortar shall be of type S having a minimum compressive strength of 12.4 MPa.

Proportioning for mortar shall be in accordance with the requirements of ASTM C 270. However it shall not be less than 1 part of cement to 4 parts of sand.

Methods and equipment used for mixing mortar will be such so as to accurately determine and control the amount of each separate ingredient entering into the mortar. Mortar shall be mixed only in sufficient quantities for immediate use and shall be used within 30 minutes after mixing. Stiffened mortars shall be re-tempered by adding water to restore the required consistency. Mortars not used within 2-1/2 hours after initial mixing shall be discarded. The mixers shall be thoroughly cleaned and washed at the end of each day's work.

### 4.3 **Bricks**

Building bricks shall conform to the requirements of ASTM C 62. Size of building bricks shall be 220 x 120 x 70 mm and as approved. The Contractor shall submit samples of building bricks for approval prior to commencement of work. Defective bricks shall not be used.

## 5.0 **PLACING**

The methods and equipment used for transporting the bricks and mortar shall be such as will not damage the brick nor delay the use of mixed mortar. Bricks shall not be placed during heavy rains to washing away the mortar from the brick. Mortar already spread which becomes diluted by rain shall be discarded and replaced before continuing with the work. All bricks to be used in brick masonry shall be soaked in water for three to four hours before they are used to ensure that each brick is thoroughly and uniformly wetted. All bricks shall be free from water adhering to their surface when they are placed in the brick masonry.

Bricks shall be laid "frog" upward with mortar joints and in stretcher bond or as approved by the Supervisor. Both bed and vertical joints shall be 10 mm in thickness completely filled with mortar as specified herein, and each brick shall be bedded by firmly tapping with the handle of trowel. All

horizontal joints shall be parallel and all vertical joints in alternate courses shall be directly over one another. Excess mortar at the outer edges shall be removed and joints drawn straight. Work required to be embedded in the brick masonry shall be installed as the work progresses. At the completion of the work all holes or defective mortar joints shall be cut out and repointed.

They shall be laid true to line, level and plumbs, all joints shall be perfectly straight, parallel and sharp. Facing brick of irregular shape, size, damaged and defective edges and faces shall be rejected outright. Works done with defective edges and faces shall be bricks shall be rejected and the Contractor shall replace, without additional cost, all defective and unacceptable works.

Exterior faces of the walls shall be finished by striking the joints as the work proceeds. Tooling shall be done when the mortar is partially set but still sufficiently plastic to bind. The joints shall be struck by raking the green mortar after the brick work has been laid and finish the joints with a pointing tool. Horizontal joints shall be struck to form a weathered joint and vertical joints shall be struck with a V notch. Care shall be taken that the striking tools do not develop a cutting edge as the object of striking the joint is to compress the mortar into the joints.

#### **6.0 CURING AND REPAIR**

All brick masonry shall be water cured and shall be kept wet for at least seven days by an approved method which will keep all surfaces to be cured continuously wet. Water used for curing shall meet the requirements of the specifications for water used in the manufacture of bricks.

If, after the completion of any brick masonry work, the brick is not in alignment or level, or does not conform to the lines and levels, shown on the drawings, or shows a defective surface, it shall be removed and replaced by the Contractor, without additional cost to Supervisor. Repair or patching of the defective area will not be acceptable unless allowed, in writing, by the Supervisor.

#### **7.0 SCAFFOLDING**

The Contractor shall provide safe scaffolding of adequate strength for use of workmen at all levels and heights at his own expense. Scaffolding which is unsafe in the opinion of the Supervisor shall not be used until it has been strengthened and made safe for use of workmen. Cost of scaffolding etc., shall be included by the Contractor without additional cost to the Supervisor.

Damage to masonry from scaffolding or from any other cause shall be repaired by the Contractor at his own cost.

#### **8.0 TOLERANCES**

All tolerances shall be as per requirements of ACI-530.1

#### **9.0. DAMP PROOF COURSES**

All damp proof courses unless otherwise specified shall be 50 mm thick, consisting of cement concrete having a 28 day minimum cube strength of 21 N/mm<sup>2</sup>, mixed with approved quality water proofing compound as per manufacturer's specifications and shall be laid at required levels as per drawings and instructions of the Supervisor. The damp proof course shall be tamped, consolidated, leveled and edges and corners made to the requirements of the relevant drawings including finishing and curing complete. No separate payment will be made for providing and laying

damp proof course.

## 10.0 **CLEANING AND PROTECTION**

At the completion of the work, all holes, and defective mortar joints shall be cut and repointed. Exposed masonry shall be protected against staining or other damage and excess mortar shall be cleared off the surfaces as the work progresses. All exposed masonry shall be clean, smooth, and fine and shall be of acceptable finish approved by the Supervisor.

## 11.0 **MEASUREMENT AND PAYMENT**

11.1 **General:** Except otherwise specified herein or elsewhere in the Contract Documents, no measurement and payment will be made for the under mentioned specified works related to the relevant items of the Bill of Quantities. The cost thereof shall be deemed to have been included in the quoted unit rate of the respective items of the Bill of Quantities.

11.1.1 Cutting & chiselling of masonry wherever required.

11.1.2 Cement sand mortar used in laying bricks including wastage.

11.1.3 Curing and repairing the masonry work.

11.1.4 All joint reinforcing bars, reinforcing anchor bars and dovetail anchors.

11.1.5 Providing and laying damp proof course.

### 11.2 **Brick Masonry**

11.2.1 **Measurement:** In case of different thickness of slab in different areas or room or for any other reason whatsoever, if chiselling of masonry is required the Contractor shall do so at his own cost. Where, for any reason whatsoever, the height of the wall is short of ceiling height of the actual height shall be made good with Class "C" concrete. This concrete shall neither be measured nor be paid under item of concrete but will be paid for under item of masonry. Similarly where the lintel heights are such that the Contractor has to chisel the masonry or provide cast-in-place concrete to make up the height of the course, no payment will be made for chiselling, but where such cast-in-place concrete is provided, payment for the same will be made at the unit rate for masonry.

Measurement of acceptably completed works of brick masonry of different thickness will be made on the basis of number of cubic meter provided & installed in position as shown on the drawing or as directed by the Supervisor.

11.2.2 **Payment:** Payment will be made for acceptable measured quantity of brick masonry on the basis of unit rate per cubic meter quoted in the Bill of Quantities & shall constitute full compensation for all the works related to the item.

## **SECTION 4600 - CARPENTRY AND JOINERY**

### 1. **SCOPE**

The work covered under this section of Specifications consists of providing all material, labour, plant, equipment, appliances and performing all operations connected with the fabrication and

erection of all wood work regarding doors, cabinet, partitions & railing including surface finish treatment, procuring and applying preservatives, installation of "Finish Hard Ware" in connection with finish woodwork as per details shown on the Drawings or as directed by the Supervisor. The scope of this section is covered with detailed specifications as laid down herein.

## 2. APPLICABLE STANDARDS

Latest editions of following British and ISO Standards are relevant to these specifications wherever applicable.

### 2.1 ISO (International Organisation for Standardisation)

- 1891 Bolts, screens, nuts and accessories-Terminology and nomenclature.
- 1097 Plywood - Measurement of dimensions of panels.
- 1098 Veneer ply wood for general use-General requirements.
- 2427 Veneer ply wood with rotary cut veneer for general use-Classification by appearance of panels with outer veneer of beech.
- 2429 Ply wood -Veneer ply wood with rotary cut veneer for general use-Classification by appearance of panels with outer veneers of brand leaved species of tropical Africa.
- 3804 Ply wood-Determination of dimension of test pieces.
- 3805 Ply wood-Determination of density.
- 3806 Ply wood-Determination of moisture content.
- 6442 Door leaves-Measurement of defects of general flatness.
- 6443 Door leaves-Measurement of dimensions and of defects of squareness.
- 6444 Door leaves-Test of behaviour under humidity variations.

### 2.2 BSI (British Standards Institution)

- 459 Wooden doors.
- 1186 Quality of timber and workmanship in joinery.
- 1127 Hinges
- 1331 Builder's hardware for housing.
- 1567 Wood door frames and linings nails.
- 1202 Nails
- 1203 Specifications for synthetic resin adhesive for ply wood.
- 1204 Synthetic resin adhesives for wood.
- 1282 Guide to choice, use and application of wood preservatives.

1494 Fixing accessories for building purposes.

1579 Connectors for timber.

3842 Treatment of ply wood with preservatives.

### 3. MATERIALS

#### 3.1 Timber

##### 3.1.1 Hard Wood :

Hardwoods shall be oak, beech, Walnut, Mahogany, Teak, Iroko or Sheesham.

##### 3.1.2 Soft Wood:

Softwoods shall be pines, spruce, hemlock and Douglas Fir or Cedrous Deodara (referred in this specification document as "Deodar"), having a minimum density of 500-600 kg/cum. The wood locally known as 'Partal' must be used in framing where specified.

##### 3.1.3 General Characteristics:

All the timber shall be in accordance with the requirements of BSI No: 1186, 'Quality of Timber and Workmanship in Joinery'.

The whole of the timber shall be from the heart of sound and fully grown tree, uniform in substance, straight in fiber, first class quality properly seasoned, free from large or loose dead knots, and open shakes and excessive sapwood. The scantlings of all timbers shall be bright, sound and square edged the moisture content of timber shall not be more than ten (10) percent.

##### 3.1.4 Preservation of Wood:

Prior to installation of all finish wood works in their respective positions, preservatives shall be applied to safeguard the wood work against fungus, termite and bores.

The preservatives shall be of the best available quality as approved by the Supervisor. The method of application shall be strictly in accordance with the manufacturer's instructions. The treatment and application of all the preservatives shall comply with the requirements of BS-CP 98:1964.

##### 3.1.5 Adhesive :

The adhesives shall conform to the requirements of BSI No. 745 "Animal Glues for Wood" or as directed and approved by the Supervisor.

##### 3.1.6 Nails and Screws:

All nails and screws shall comply with requirements of BSI NO. 1202 and BSI NO. 1210 respectively.



### 3.2 Ply Wood

3.2.1 The ply wood shall comply in all respects with BSI No. 1455:1963. All the ply wood shall only be obtained from manufacturers approved by the Supervisor.

Ply wood used for doors, paneling and other similar works shall be to the thickness and size as shown on the Drawings or as directed by the Supervisor. The grade shall be first quality and the face and back shall be free from end joints, dead knots, overlaps, patches and other similar defects. The surfaces shall be free smooth for painting or polishing.

3.2.2 The veneer shall be of the required thickness and quality including base veneer and shall be impregnated with an approved adhesive and machine compressed. Such machine pressed veneered wood shall be fixed on all sides of the inner core wood (soft wood of approved quality) after it has been treated with water resistant hot setting glue.

## 4. **SAMPLES**

All samples of the material used for the work under this Section of Specification shall be approved by the Supervisor and same type of material shall be used throughout the work. If the Supervisor desires to get the material tested, this will be got done by the Contractor at his own cost from a laboratory approved by the Supervisor.

## 5. **FABRICATIONS**

### 5.1 **General**

'Unwrought' timber shall be used. Sawing shall be done true to the size and dimensions to finally meet the requirements of specified sizes and dimensions of the finished work.

All framing shall be joined as shown on the Drawings or as directed by the Supervisor. All joints shall be secured with sufficient number of nails. The Contractor shall perform all necessary mortising, grooving, matching, tonguing, housing, rebating and all operations required for the correct jointing. The Contractor shall also provide all metal plates, screws, nails and other fixing material that may be ordered by the Supervisor for the proper execution of the joinery work. Fabrication that develop defects due to bad workmanship or unsound materials not conforming to these specifications and the directions of the Supervisor, shall be cut out and replaced at Contractor's own expense before the expiry of the maintenance period.

### 5.2 **Doors**

5.2.1 Verify design and size of doors required for each opening. Door thicknesses shall be 40mm unless otherwise indicated.

5.2.2 Fabricate flush wood doors in accordance with the following requirements.

#### Cores

Edging of doors and shutters shall be of hard wood and cores shall be soft wood (solid core) planed to a smooth uniform thickness. All doors and shutters shall have hardwood lapping on all edges.

#### Face Panels

- Door facing on each side of door shall consist of three or more veneered commercial plies.
- Veneer plies shall have total minimum thickness of 3mm before sanding.
- Door veneers shall be bonded to each other, and to core unit with approved adhesive and machine compressed.

## 6. PROTECTION OF MATERIALS

All materials and assembled units shall be protected from weather and stored in such a way as to prevent decay and attack by fungus and termites.

## 7. WOODEN DOORS

### 7.1 Materials

7.1.1 First class Deodor Wood as approved by the Supervisor shall be used for the door frames and full/half glazed and paneled shutters.

7.1.2 The ply wood and veneering shall be of selected best quality as approved by the Supervisor.

### 7.2 Ground, Blocking & Nailing Strips

Ground, blocking and nailing strips shall be provided as necessary to receive the work included herein and as required for the work of other trades.

Except as otherwise shown or specified, ground blocking and nailing strips shall be secured in place as follows:

7.2.1 To steel: By means of 9.53mm diameter bolts spaced not over 900 mm.

7.2.2 To concrete block: By the use of cut nails spaced not more than 400mm apart and driven directly into the block.

7.2.3 To poured concrete: By means of 6.35mm diameter galvanized expansion bolts spaced not more than 400mm apart or by any approved method.

### 7.3 Interior Door Frames

All exterior and interior door frames shall be constructed of given thickness with planted on stops, nailed in place, jambs and beads shall be housed and nailed and glued together.

The door frames shall be secured in place by means of mild steel anchors screwed in place and built into the masonry as it is being constructed. There shall be one such anchor near the top and bottom of each jamb but not over 3ft. intervals between the top and bottom anchors.

### 7.4 Interior Wooden Doors (on Drawings, Doors D-1, D-2, D-5, D-6)

The interior wooden door shall, unless otherwise shown or specified, be of the paneled type, flush or swing type as shown on the Drawings or as directed by the Supervisor. All the doors shall conform to the following requirements:

Paneled doors shall be constructed in accordance with the requirements of Part I of British Standard Specification No. 459 with the additional requirements that panels in exterior openings shall be assembled with waterproof glue. Flush door shall comply with BSI 459 Part-2 and shall consist of solid core commercial ply veneer 40mm thick shutters as shown on drawings.

7.6 **Door Window and Ventilator Shutters (not used)**

7.7 **Fitting, Hanging and trimming**

All the doors shall be fitted, hung and trimmed as hereinafter specified.

Doors shall have a clearance of 4mm at sides and top unless otherwise directed by the Supervisor and shall have 3mm clearance at bottom. Doors shall be hung and trimmed with hardware as specified. All the locks shall be installed at the same height and shall be located at height as directed by the Supervisor.

7.8 **Hardware**

Hardware shall be of best quality make extra heavy duty and first class finished material as per hardware schedule shown on the drawings. The Contractor shall obtain prior approval from the Supervisor for quality, shape, pattern, and brand of all the hardware materials by providing samples and catalogues, etc., and shall provide and fix only the approved hardware materials.

Hardware shall be carefully and securely fitted. Upon handing over the work, hardware shall be demonstrated to freely. Keys shall be placed into respective locks and upon acceptance of the work keys shall be tagged and delivered to the Supervisor.

For details of hardware refer door, window schedule.

7.9 **Quality Assurance**

7.9.1 **Tolerances: Doors shall be fabricated to following tolerances**

- Size: Plus or minus 1.6 mm overall dimensions
- Maximum Warp: 3 mm
- Squareness: Maximum diagonal difference 3 mm (between length of diagonal measured on face of door from upper right corner to lower left corner and length of diagonal measured from upper left corner to lower right corner).

7.9.2 **Manufacturer's Qualifications:** The manufacturer of doors herein specified shall have been in business of manufacturing doors of type specified for minimum period of five years.

7.10 **Submittals**

7.10.1 Provide manufacturer's literature completely describing products.

7.10.2 Provide shop drawings showing door types, details and locations, referred to the door type and hardware group shown on door and hardware schedules.

7.10.3 Provide certificates stating that doors were constructed with timber of the species specified having moisture content and meeting equilibrium and relative humidity requirements.

7.10.4 Submit samples of face veneers for selection of color and pattern.

7.10.5 Procurement of materials shall be made only after the shop drawings and samples have been approved by the Supervisor.

7.11 **Product Delivery, Storage and Handling**

7.11.1 Deliver and store products in waterproof, protective containers with seals unbroken and labels intact until time to use.

7.11.2 Keep products dry, stack products off ground on including direct sunlight.

7.11.3 Identify type, size and location of each door before delivery in order to permit installation at correct location.

7.12 **Installation**

7.12.1 Install doors at correct openings and assure smooth swing and proper closer with frames.

7.12.2 Install finish hardware in accordance with manufacturer directions.

8. **DEODAR WOOD BEADING (not used)**

9. **WOODEN and METAL RAILING (not used; See Stainless Steel Section 3010 for the stairwell hand rail specification)**

10. **WOODEN CABINETS/SHELVES (not used)**

11. **DEFECTIVE WORK**

In the event of non-conformance to specification and drawings, the wood works shall be rejected by the Supervisor and the Contractor shall remove and replace the rejected work by new work of same specifications.

12. **SURFACE PREPARATION**

The surfaces of all wood works shall be prepared in the manner as directed by the Supervisor for painting.

13. **MOCK-UP SAMPLE**

After approval of shop drawings and tests etc., the Contractor shall submit and place at his own cost one mock-up sample of each type of wood works complete with all fittings, fixtures accessories prior to the actual fabrication of the bulk.

The samples shall be returned to the Contractor for incorporation in the works after installation of at least 80% of the works.

14. **MEASUREMENT & PAYMENT**

14.1 **General**

Except otherwise specified herein or elsewhere in the Contract Documents, no measurement and payment will be made for the under mentioned specified works related to the relevant items of the Bill of Quantities. The cost thereof shall be deemed to have been included in the quoted unit rate (square meters of door unit, including frame) of the respective/items of the Bill of Quantities.

14.1.1 All finished hardware fittings in carpentry and joinery works.

14.1.2 Prime coat, painting and polishing in carpentry and joinery works.

14.1.3 Anti termite/preservative treatment to wood works.

14.1.4 Adhesives

14.1.5 Timber batten, counter sunk screw.

14.2 **Wooden Doors.**

14.2.1 **Measurement**

Measurement of acceptably completed works of all types of wooden doors will be made on the basis of area in square meter of doors fabricated, provided and installed in position as shown on the Drawings or as directed by the Supervisor.

14.2.2 **Payment**

Payment will be made for acceptable measured quantity of all types of wooden doors on the basis of unit rate per square meter quoted in the Bill of Quantities and shall constitute full compensation for all the works related to the item.

14.3 **Kitchen cabinet**

14.2.1 **Measurement**

Measurement of acceptably completed works of wooden cabinets will be made on the basis of length in running meter of cabinet fabricated, provided and installed/mounted in position as shown on the Drawings or as directed by the Supervisor.

14.2.2 **Payment**

Payment will be made for acceptable measured quantity of all types of wooden cabinets on the basis of unit rate per running meter quoted in the Bill of Quantities and shall constitute full compensation for all the works related to the item.

14.3 **Reception Counter (not used)**

#### 14.3.1 Measurement

Measurement of acceptably completed works of Reception counter will be made on the basis of length in running meter of counter fabricated, provided and installed/mounted in position as shown on the Drawings or as directed by the Supervisor.

#### 14.3.2 Payment

Payment will be made for acceptable measured quantity of reception counter on the basis of unit rate per running meter quoted in the Bill of Quantities and shall constitute full compensation for all the works related to the item.

### **SECTION 6220 - ALUMINIUM AND PVC WORKS**

#### **1. SCOPE**

The work covered under this section of the specifications consists of providing all material, labour, equipment, performing all operations required for providing and installation of aluminium doors and windows, including all related items such as sealants, gasket, netting, rollers, hinges, latches, fastenings, anchor bolts, door locks, locking devices and glass complete in strict accordance with this section of specifications, the applicable drawings and as scheduled. Any additional information required in this connection and not stated in these specifications, shall be obtained from the Supervisor's Representative. The Terms "Aluminium" and "Aluminium" are interchangeable. This section also applies to the construction of the glass and aluminium-framed dome on the roof of the building.

#### **2. APPLICABLE STANDARDS**

Latest editions of following ISO and British Standards are relevant to these Specifications wherever applicable.

##### **2.1 ISO (International Organisation for Standardisation)**

1804	Doors	-	Terminology
6442	Door Leaves	-	Measurement of defects of general flatness.
6443	Door Leaves	-	Measurement of dimensions and defects of squareness.
6444	Door Leaves	-	Test of behaviour under humidity Variations (successive uniform climates)
6612	Windows & Doors	-	Wind resistance tests.
6613	Windows & Door	-	Air permeability test.

##### **2.2 BSI (British Standard Institution)**

1227	Hinges
4873	Aluminum alloy windows.

#### **3. GENERAL**

3.1 Doors and Windows and other items to be provided shall be aluminium, of profile pattern and design shown on drawings and shop drawings manufactured by reputable

manufacturer approved by the Supervisor. The contractor shall provide manufacture literature completely describing the product instructions for installation and maintenance.

3.2 All the sections used for doors and windows and fly screens shall be of best quality aluminium products such as equal and unequal angles, channels, tubes, corrugated strips, moldings etc., in accordance with International standards conforming to ASTM B 308 & B 221.

3.3 All doors and windows shall be of type and size indicated on drawings and shall conform to the requirements shown and specified herein.

3.4 Contractor shall arrange tests and analysis if directed by the Supervisor of scaled models of each door and window type at the maker's works or any laboratory specified by the Supervisor for the material supplied by him to be tested in the presence of the Supervisor's Inspector, to whom test certificates, proof sheets, etc. shall be furnished. The models shall be submitted to the Supervisor for approval prior to testing. Nevertheless, neither the fact that the materials have been tested in the presence of the inspector nor that the Supervisor may have been furnished with test certificates in lieu of sending an inspector to the works shall affect the liberty of the Supervisor to reject, after delivery of materials found not in accordance with these specifications.

3.5 The contractor shall submit shop drawings conforming to design concept which shall show full construction details, quantities and locations, fastenings, stiffening members and attachments to adjacent construction and materials. Shop drawings and calculations shall be submitted at the proper time to allow for checking, revisions, and agreement and to permit manufacturer's product delivery and start of site work to suit the building programme. The Contractor shall submit representative samples of finished doors, windows, anchoring mechanism, embedded parts, fastenings, glass panes, accessories and other materials for the Supervisor's approval.

After approval of shop drawings and tests etc., the Contractor shall submit at his own cost one mock-up sample of each type of aluminum works complete with glazing, all components assembly method and required fittings and accessories prior to the actual fabrication of the bulk. The samples shall be returned to the Contractor for incorporation in the works after installation of at least 80% of the works.

Fabricate and assemble all work in the shop of the approved manufacturer to reduce field fabrication to a minimum unless otherwise directed by the Supervisor.

3.6 The glass shall conform to specification laid down under chapter 'Glazing' and shall be free from all blemishes, bubbles, distortions and other flaws of any kind and shall be properly cut to size as shown on drawings, so as to fit the grooves in window members.

3.7 The structural shape of the Aluminum members shall be of uniform quality, colour and temper, clean, round, commercially straight and free from injurious defects.

3.8 All doors and windows shall be fabricated as a complete unit, fully airtight and watertight, including rubber gasket for glazing, hinges, stays, rollers, latch, locking arrangement, handles, etc anodized in specified colour, inclusive of glass sheet, necessary holes for fixing, door locks, door closures and window locking requirements, all as approved by the Supervisor.

- 3.9. Contractor shall, provide certificate signed by the manufacturer stating that each lot has been sampled, tested and inspected and has met the requirements in accordance with these specifications and the same shall be furnished to the Supervisor.
- 3.10 The shop drawings shall clearly show that there shall be no penetration of rainwater from the exterior to the interior in case of severe wind and rainstorm. This has to be specially ensured in sill section.

#### 4. **MATERIAL**

##### 4.1 **Frames**

The frames of aluminum door and windows shall be formed from rolled, strip or extruded aluminum. The thickness of sectional members shall be at least 2.0 mm. All outer / frame sections of open able / fixed windows. The Frames for doors and door/windows shall be at least 4" (100 mm) in width.

- 4.2 As shown on the drawings, aluminum frames shall be provided as per international standard approved by the Supervisor.
- 4.3 Fasteners shall be stainless steel of a type selected to prevent galvanic action with the components fastened.
- 4.4 Gaskets shall be vinyl glazing channel gasket to commercial standard CS-230-60.
- 4.5 Hardware shall be manufacturer's standard hardware. Flush to match doors and windows finish. Floor mounted concealed type double action/swing imported door closures shall be provided to all doors. Heavy duty in-matching finish stays shall be provided to all openable windows. Stays shall be attached to the window frame so as could be replaced easily.
- 4.6 Joint sealant shall be approved elastomer.
- 4.7 All Aluminum sections shall be powder coated in accordance with the standards of Aluminum Association of USA. The anodisation shall be of not less than 70-90 microns. The anodic oxide surface shall be properly sealed.
- 4.8 For powder coated finish aluminum sections to be coated shall be mill finish. The sections shall be firstly degreased with a degreasing chemical to remove all/any stains. The sections will then be given a chromating coating and electro static powder coating in the desired colour with a powder-coating machine. After colour coating the sections will be baked at baking temperature of 220 degree Centigrade for 25 minutes.
- 4.9 All sliding/openable windows shall have sliding/openable wire/fly screen shutters in window matching finish with wire/fly screen of size so as not to permit the entry of flies and mosquitoes. The wire mesh shall be 30 SWG. 14 mesh (14 x 14 openings per square inch).

#### 5. **DESIGN REQUIREMENT**

The Contractor shall design the installation to meet or exceed the following requirements.

##### 5.1 **Tolerances**



The Contractor shall be responsible for agreeing to all dimensions with the Supervisor before proceeding with the manufacture and for making provision to allow for building tolerances required by the Supervisor. Contractor shall also take site measurements of the structure completed before manufacturing.

#### 5.2 **Thermal & Seismic Movements**

The window and glazing assemblies are to be constructed and installed in the openings with sufficient tolerance and, where necessary, to provide for joints incorporated in couplings, to provide for expansion and contraction as will be caused by the local seismic and climatic conditions and temperature changes, winter to summer - day to night without buckling, distortion of joints, or other harmful effects.

### 6. **WORKMANSHIP**

The Contractor shall be responsible for the protection and installation of all items furnished. All items shall be installed plumb and square and shall be solidly anchored in a good workman like manner in accordance with the manufacturer's instruction and as specified herein. The Contractor shall be responsible for the protection of installed items from damage by other trades. All items shall be left in operating, neat and clean condition, free from dirt, finger marks, etc. The Contractor shall be responsible for final cleaning before the final acceptance.

The glass panes shall firmly be secured in the rebates with the rubber gasket. Ensure that the beads and grooves are clean, dry and unobstructed at the time of glazing. The complete unit shall be airtight and watertight on completion. No doors and windows shall be considered complete until and unless the fingerprints and other stains and marks have been removed from the surface of glass and aluminum.

### 7. **PRODUCT DELIVERY AND STORAGE**

7.1 Deliver doors and windows in a manner preventing damage to units. Store materials off the ground under cover in a manner preventing deterioration or damage.

7.2 All embedded parts and anchor bolts shall be delivered to the site carefully and keeping the fabricated shape and configuration. All these parts shall be suitably marked for identification.

8. **ERECTION**

Rawal plugs and anchoring bolts shall be embedded into the concrete or block masonry for holding the doors and windows in their correct positions.

Care shall be taken to install the doors and windows in line and plumb & solidly anchored in a good workman like manner in accordance with the drawings. Should any scale or scratch appears on the surface of doors and windows the contractor shall at his own expense and at the Supervisor's direction have all exposed surfaces cleaned to bare bright specified colour.

All works shall be installed in strict accordance with the manufacturer's printed instructions.

9. **SCAFFOLDING**

Contractor shall provide safe scaffolding of adequate strength for use of workmen at all levels and heights at his own expense. Scaffolding which is unsafe in the opinion of the Supervisor shall not be used until it has been strengthened and made safe for use of workmen. Cost of scaffolding etc., shall be included by the Contractor in the unit rate of items.

Damage to existing works from scaffolding or from any other object shall be repaired by the Contractor at his own cost.

10. **PROTECTION AND CLEANING**

10.1 Temporary protection shall be achieved by applying water-soluble protective coating capable of withstanding the action of lime mortar.

10.2 Apply coating in the manufacturer's plant to the exposed surfaces of all components.

10.3 Before application of coating, remove all fabrication compounds, moisture and dirt accumulations.

11. **DEFECTIVE WORK**

In the event of non-conformance to specifications and drawings the aluminium works shall be rejected by the Supervisor and the Contractor shall remove and replace the rejected works by new work of same specifications.

12. **GUARANTEE**

12.1 The manufacturer shall furnish his standard written guarantee against leakage of rain, excessive infiltration of dust and air and all defects in materials and workmanship covering all work under this section. No payment shall be made for any arrangement required to be provided in the sections for complete protection against water leakage any damages caused to the furniture & furnishings, plant and equipment due to leakage of water shall be fully recovered from the Contractor.

12.2 Such guarantee shall be in addition to and not in lieu of all other liabilities which manufacturers and the Contractor may have by law or by other provisions of the Contract Documents.

13. **MEASUREMENT AND PAYMENT**

### 13.1 **General**

Except otherwise specified herein or elsewhere in the Contract Documents, no measurement and payment will be made for the specified works related to the relevant items of the Bill of Quantities. The cost thereof shall be deemed to have been included in the quoted unit rate (square meters of area, including frame) of the respective items of the Bill of Quantities.

13.1.1 Aluminium extrusions tubular frame and sash member as per drawings.

13.1.2 Polyurethane thermal break material.

13.1.3 Rawal plugs, brackets, rubber gasket, sealants, rollers, heavy duty hinges, stays, concealed type floor mounted double action door closures, hinges, heavy duty stays, vetting latches and any other embedded fixture required for fixing the doors and windows.

13.1.4 Providing and fixing fly screens, weather stripping, backer rods, locks, stays, latches, push/pull bars, handles and door closures where ever required in the aluminium works as approved by the Supervisor.

13.1.5 Cleaning of aluminium after installation.

13.1.6 Sealing all around both from inside and outside and also of the screw holes with silicone sealant to avoid water leakage.

13.1.7 Fly screen including wire/fly mesh etc. in windows.

13.1.8 Powder coating of Aluminium works.

13.1.9 Providing and fixing glazing

13.1.10 All samples & tests

### 13.2 **Anodized Aluminium Works**

#### 13.2.1 **Measurement**

Measurement of acceptably completed works of anodized aluminium doors and windows will be made on the basis of net actual area in square meter provided and installed in position as shown on drawings or as directed by the Supervisor.

#### 13.2.2 **Payment**

Payment will be made for acceptable measured quantity of all finished anodized aluminium doors and windows on the basis of unit rate per square meter quoted in the Bill of Quantities and shall constitute full compensation for all the works related to the item including all reinforcing / stiffening arrangements.

## **2.8 PVC - 7000 WINDOWS AND WINDOW HARDWARE**

### 2.8.1 GENERAL

#### 2.8.1.1 Interpretation

## Definitions

For the purposes of this work section windows also includes louvers, either vertical or horizontal, set into frames.

### 2.8.1.2 Inspection

#### Notice

Give sufficient notice so that inspection may be made of the following:

- Openings prepared to receive windows (where windows are to be installed in prepared openings).
- Fabricated window assemblies delivered to the site, before installation.
- Commencement of window installation.

## 2.8.2 PRODUCTS

### 2.8.2.1 Louvre assemblies

#### General

Provide louver blades mounted in a surround frame and able to withstand the wind pressure for that location without failure or permanent distortion of blades, and without blade flutter.

#### Adjustable louvers

Provide louver blades clipped into holders which pivot, linked together in banks, each bank operated by an operating handle incorporating a latching device, or by a locking bar.

### 2.8.2.2 Fly Screens Mesh

Provide metallic coated fly screen mesh behind louvers to prevent the entry of mosquitos, birds, rodents and windblown leaves and papers.

#### Insect screens

#### Fibreglass fly screen

Provide insect screens with mesh frame channel. Provide an extended frame section where necessary to adapt to window opening gear.

Mesh: Fix the mesh into the frame channel with a continuous resilient gasket, so that the mesh is taut and without distortion.

#### Fixed Screens

Provide fixed screens to the window frames with a clipping device which permits removal for cleaning.

#### Hinged Screens

Hinge at the side to give access to opening sash.

#### Sliding Screens

Provide a matching aluminium head guide, sill runner, and frame stile sections for screens not part of the window frame.

Hardware: Nylon slide runners and finger pull handle.

### 2.8.2.3 PVC Window Frames

#### PVC Frames

To be assembled from plastic PVC sections, including necessary accessories tools and best quality and suitable for fixing specified hardware.

#### Timber Frames

To be constructed with best quality timber. Obtain approval from the Engineer for the timber selection before use. Construct as shown on the drawings and ensure that all joints are securely made to avoid distortion of the frame in use.

#### Steel Frames

To be folded from metallic-coated steel sheet sections, joints to be continuously welded, including necessary accessories such as buffers, strike plates, spreaders, fixing ties or brackets, and suitable for fixing specified hardware.

Finish: Grind the welds smooth, prepare and paint the welded joints with primer. Then prime the entire frame.

### 2.8.2.4 Installations of PVC windows.

Deliver windows to the project site in an undamaged condition. Use care in handling and Hoisting windows during transportation and at the job site. Store windows and components Out of contact with the ground, under a weather tight covering, to prevent bending, Warping, or otherwise

damaging the windows. [Store windows and components so they will not have to be handled at minus 28 degrees C 20 degrees F or colder.] Repair damaged windows to an "as new" condition as approved. Provide new units if windows cannot be repaired.

#### 2.8.2.5 Sustainable Design Requirements

##### Plastic Identification

Verify that plastic products to be incorporated into the project are labeled in accordance with ASTM D 1972. Where products are not labeled, provide product data indicating polymeric information in Operation and Maintenance Manual.

##### PVC Windows Materials

Provide PVC, reinforcing members, fasteners, hardware, weathers tripping, and anchors conforming to AAMA/WDMA/CSA 101/I.S.2/A440 or ASTM D 4099 and as specified herein.

#### 2.8.2.6 Windows Type

##### Casement Windows

AAMA/WDMA/CSA 101/I.S.2/A440, Type C- [R 15] [C 20] [HC 40] [(Optional Performance Class)] Or ASTM D 4099. Ventilators shall be [rotary crank] [handle] operated. Provide ventilators over 1675 mm 66 inches high with two separate locking devices or a two-point locking device operated by rods from a single lever handle. Conceal rods where possible. Provide compression-type weathers tripping. Provide casement windows in combination with fixed projected.

##### Corners and Reinforcement

Corners of PVC frames and sashes shall be [mechanically fixed and sealed or welded] [welded]. Reinforce frames and sash as necessary to meet the requirements for the performance classes or grades specified herein.

##### Provisions for Glazing

Design windows and rabbets suitable for glass thickness shown [or specified]. Design sash for [inside] [outside] [single] [double] [triple] glazing and for securing glass with [glazing beads,] [glazing clips,] [Glazing channels,] [Glazing gaskets,] [or glazing compound].

##### Hardware

The item, type, and functional characteristics shall be the manufacturer's standard for the particular window type. Provide hardware of suitable design and of sufficient strength to perform the function for which it is used. Equip operating ventilators with a lock or latching device which can be secured from the inside.

##### Color

Window (PVC) color shall be [white] Color shall be integral or Co-extruded to the PVC to prevent heat build-up.

##### Fasteners

Provide fastener types as standard with the window manufacturer for Windows, trim, and accessories. Fabricated from 100 percent re-melted Steel.

##### Window Blinds

Provide windows complete with clips, fins, anchors, [grills,] [venetian Blinds,] and other appurtenances necessary for complete installation and Proper operation.

##### Anchors

Provide concealed anchors of the type recommended by the window manufacturer for the specific type of construction. Anchors and fasteners shall be compatible with the window and the adjoining construction. For each jamb 900 mm 36 inches or longer, provide a minimum of three anchors located approximately 150 mm 6 inches from each end and at midpoint. For jambs less than 900 mm 36 inches long, provide two anchors.

#### Window-Cleaner Anchors

Provide double head anchors for windows [indicated] [specified]. Anchors shall be stainless steel of size and design conforming to ASME A39.1.

Provide two anchors for each single window [and each adjacent fixed glass window unit]. Fasten anchors 1120 mm 44 inches above the window sill in accordance with ASME A39.1. Reinforce frames to receive anchors. Provide wall anchors on backs of frames at points.

#### Grills

Provide the manufacturer's standard grills for the windows indicated. Grills shall be removable or shall be sealed within insulating glass units. Unless otherwise indicated, grill pattern shall be the manufacturer's standard design or as approved.

#### Integral Venetian Blinds

Provide the manufacturer's standard venetian blinds mounted within the window frame for the windows indicated. Venetian blinds shall be fully adjustable allowing full angle tilting and stops at any position. Color of blinds shall [be white] [match the color of the PVC].

### 2.8.2.7 INSTALLATION

Install in accordance with the window manufacturer's printed instructions and details. Build in windows as work progresses or install without Forcing into prepared window openings. Set windows at proper elevation, Location, and reveal; plumb, square, level, and in alignment; and brace, strut, and stay properly to prevent distortion and misalignment. Bed screws or bolts in sill members, joints at mullions, and contacts of windows with sills, built-in fins, and sub frames in mastic sealant of a type recommended by the window manufacturer. Install and seal windows in a Manner that will prevent entrance of water and wind. [Fasten insect screens securely in place.] Fasten hardware to windows.

#### Anchors and Fastenings

Secure units to each other, to masonry, and to other adjoining construction with clips, fins, screws, or other devices recommended by the window manufacturer. [Where window cleaner anchors are provided, anchor windows and mullions to provide safe and adequate support for the window cleaner.]

#### ADJUSTING

After installation of windows and completion of glazing and field painting, adjust ventilators and hardware to operate smoothly and to provide weather tight sealing when ventilators are closed and locked. Lubricate hardware and operating parts as necessary. Verify products are properly installed, connected, and adjusted.

#### CLEANING

Clean interior and exterior surfaces of window units of mortar, plaster, paint spattering spots, and other foreign matter to present a neat appearance, to prevent fouling of weathering surfaces and weathers tripping, and to prevent interference with operation of hardware. Replace stained, discoloured, or abraded windows that cannot be restored to their original condition with new windows.

### 2.8.2.8 Security Window Grilles

#### General

Provide security grilles in accordance with the drawings or proprietary metal security grille screens, fixed to the building structure with tamper resistant fastenings.

### 2.8.2.9 Flashing and Weathering

Install moulds, sealant and cement pointing as required so that water is prevented from penetrating the building between the window frame and the building structure.

### 2.8.3 FIXING AND FASTENERS

Materials: Use materials compatible with the item being fixed and of sufficient strength, size and quality to perform their function.

Concealed fixings: Provide a corrosion resistant finish.

Exposed fixings: Match exposed fixings to the material being fixed.

Support: Provide appropriate back support (for example blocking and backing plates) for hardware fixings.

Window fastener spacing (nominal): 600 mm.

Window fasteners: Conceal fasteners where possible.

Packing: Pack behind fixing points with durable full width packing.

Prepared masonry openings: If fixing timber windows into existing prepared openings with fastenings through the frame face, make the fastener heads finish below the surface and fill the hole for a smooth surface finish.

#### 2.8.3.1 Joints

Make accurately fitted tight joints so that neither fasteners nor fixing devices such as pins, screws, adhesives and pressure indentations are visible on exposed surfaces.

#### 2.8.3.2 Operation

Ensure moving parts operate freely and smoothly, without binding or sticking and are lubricated.

Supply

Deliver window hardware items, ready for installation, in individual complete sets for each window.

In a separate dust and moisture proof package labelled for the specific window.

Including the necessary templates, fixings and fixing instructions.

Refer to the drawings and Window, Louvre and Security grille/shutter schedules for details of windows. Refer to the Window hardware schedule for details of window hardware.

#### 2.8.3.3 Completion

#### 2.8.3.4 Cleaning

The Contractor is to clean all frames, glass, and hardware at completion. Any damage to frames or broken glass is to be repaired or replaced to the satisfaction of the Engineer.

#### 2.8.3.5 Adjustment

Leave the hardware properly adjusted with working parts in working order and lubricated where appropriate.

### 13.2 **Anodized PVC Works**

#### 13.2.1 **Measurement**

Measurement of acceptably completed works of anodized PVC windows will be made on the basis of net actual area in square meter provided and installed in position as shown on drawings or as directed by the Supervisor.

#### 13.2.2 **Payment**

Payment will be made for acceptable measured quantity of all finished anodized PVC windows on the basis of unit rate per square meter quoted in the Bill of Quantities and shall constitute full compensation for all the works related to the item including all reinforcing / stiffening arrangements.

### 2.9 **PVC - 7000 DOORS AND DOOR HARDWARE**

#### 2.9.1 **GENERAL**

##### 2.9.1.1 Interpretation

Definitions

For the purposes of this work section the definitions given below apply.

Door frame: Includes door trims.

Door set: An assembly comprising a door or doors and supporting frame, guides and tracks including the hardware and accessories necessary for operation.

Fire-door set: A door set which retains its strength and limits the spread of fire.

Smoke-door set: A door set which restricts the movement of smoke.

Flush door: A door leaf having two flat faces which entirely cover and conceal its structure. It includes doors with cellular and particleboard cores.

Joinery door: A door leaf having stiles and rails, framed together. A joinery door may also incorporate glazed panels.

Louvered door: A joinery door in which the panel spaces are filled in with louver blades.

#### 2.9.1.2 Inspection

##### Notice

Give sufficient notice so that inspection may be made of the following:

- Door frames standing in place before building in to brickwork.
- Door frames installed before fixing trim.

#### 2.9.1.3 Submissions

##### Samples

Submit samples of all hardware items for approval by the Engineer before use in the works.

##### Subcontractors

Automatic sliding door assemblies: Submit names and contact details of proposed supplier and installer.

##### Product Warranties

Automatic sliding door assemblies: Submit a warranty from the supplier and installer for the system and its installation, for a period of at least twelve months from the date of completion.

Hardware: Submit the warranties offered by the manufacturer for the hardware items provided in the works.

##### Keys

Key codes: Submit the lock manufacturer's record of the key coding system showing each lock type, number and type of key supplied, key number for re-ordering, and name of supplier.

Keys: For locks keyed to differ and locks keyed alike, verify quantities against key records, and deliver all keys and records to the Engineer at completion.

##### Plastic Identification

## Frames

### Aluminium Frames

To be assembled from aluminium sections, including necessary accessories such as buffers, strike plates, fixing ties or brackets, and suitable for fixing specified hardware.

### Timber Frames

To be constructed with best quality timber. Obtain approval from the Engineer for the timber selection before use. Construct as shown on the drawings and ensure that all joints are securely made to avoid distortion of the frame in use.

### Steel Frames

To be folded from metallic-coated steel sheet sections, joints to be continuously welded, including necessary accessories such as buffers, strike plates, spreaders, fixing ties or brackets, and suitable for fixing specified hardware.

Finish: Grind the welds smooth, prepare and paint the welded joints with primer. Then prime the entire frame.

Hardware and accessories: Provide for fixing hardware including hinges and closers, using 4 mm back plates inside the frame. Screw fix the hinges into the back plates.

Base metal thickness:

General:  $\geq 1.1$  mm.

Fire rated door sets:  $\geq 1.4$  mm.

Security door sets:  $\geq 1.6$  mm.

## Doors

### Flush Doors

Cellular core flush doors:



Provide a sub frame of 25 mm minimum width timber around openings for louvers and glazing.  
Provide additional material to take hardware and fastenings.

Cut outs: If openings are required in flush doors (e.g. for louvers or glazing) make the cut outs not closer than 120 mm to the edges of the doors.

Solid core flush doors:

Core of timber strips laid edge to edge, fully glued to each other and to facings each side of no less than two sheets of timber veneer.

Single thickness of moisture resistant general purpose particleboard.

Refer to drawings and **Flush Doors** schedule for details.

#### Joinery Doors

Fabricate joinery doors as shown on the drawings and in the **Joinery Doors** schedule.

#### PVC Doors

Fabricate PVC doors as shown on the drawings and in the **PVC Doors** schedule.

#### Construction

Form rebates to suit standard rebated door hardware.

Louvre grilles: Construct by inserting the louver blades into a louver frame, and fix the frame into the door.

#### Double doors

Provide rebated meeting stiles unless the doors open in both directions. Chamfer square edged doors to prevent binding between the leaves.

### **Door sets**

#### Automatic Sliding Door Assemblies

Provide auto sliding door assemblies in accordance with the **Automatic door schedule**.

#### Toughened Glass Door Assemblies

Provide toughened glass door assemblies with matching concealed hinges and patch fittings as appropriate. Ensure that all glass edges are protected during installation and polish on completion.

#### Fire-Resistant Door sets

Provide fire resistant doors and frames as matched sets for door openings required to have a fire rating. Refer to the **Fire and smoke resistant door sets schedule** for details.

Provide copies of test certificates from recognised authorities proving the performance of the door sets.

#### Smoke-Resistant Door sets

Provide smoke resistant doors and frames as matched sets for door openings required to have a smoke stopping capability. Refer to the **Fire and Smoke Resistant Door sets** schedule for details.

Provide copies of test certificates from recognised authorities proving the performance of the door sets or seals to frames.

#### Security Screen Door sets

Provide security screen door sets in accordance with the **Security Screen Doors** schedule.

### **Ancillary materials**

#### Nylon brush seals

To be dense nylon bristles locked into galvanized steel strips and fixed in a groove in the edge of the door or in purpose-made anodised aluminium holders fixed to the door

#### Pile weather strips

To be polypropylene or equivalent pile and backing, low friction silicone treated, ultra-violet stabilised.

#### Door Seals

To be proprietary items as identified in Schedules and to approval of Engineer.

### **Hinges**

#### Butt hinge sizes

Refer to **Hinge Table A** and **Hinge Table B** in which length (l) is the dimension along the knuckles, and width (w) is the dimension across both hinge leaves when opened flat.

Steel, stainless steel, brass, bronze butt hinges for timber doors in timber or steel frames: To **Hinge table A.**

Aluminium hinges for aluminium doors, or for doors of other materials in aluminium frames: To **Hinge table B.**

Hinge materials

Aluminium hinges: High tensile aluminium with fixed stainless steel pins in nylon bushes, and with nylon washers to each knuckle joint.

Doors fitted with closers: Provide low friction bearing hinges.

Hinge Pins

Exterior or security doors opening out: Provide fixed pin hinges.

*Hinge Table A*

Nominal hinge size l x w x t (mm)	Door leaves not exceeding any of the following		
	Mass (kg)	Width (mm)	Thickness (mm)
70 x 50 x 1.6	16	620	30
85 x 60 x 1.6	20	820	35
100 x 75 x 1.6	30	920	40
100 x 75 x 2.5	50	920	50
100 x 75 x 3.2	70	1020	50
125 x 100 x 3.2	80	1220	50

*Hinge Table B*

Nominal hinge size l x w x t (mm)	Door leaf not exceeding mass (kg)	Minimum construction	
		Knuckles	Screws/hinge leaf
100 x 70 x 3	30	3	3
100 x 80 x 3.5	50	5	4

Number of Hinges

Provide 3 hinges for doors up to 2200 mm high, and 4 for door leave between 2200 mm and 3000 mm high.

Wide Throw

If necessary, provide wide throw hinges to stop doors binding on obstacles such as nibs or deep reveals.

**Door Hanging Systems**

General

Provide sliding door tracks in conformance with the schedules.

**Locks and Latches**

General Door Hardware

Provide hardware of sufficient strength and quality to perform its function, appropriate to the intended conditions of use and climate and fabricated with fixed parts firmly joined.

Bolts

Provide bolts including barrel bolts and tower bolts with associated hardware, including lock plates, ferrules or floor sockets.

Furniture

Provide lock and latch furniture suitable for use with the lock or latch to which it is installed with the corresponding level of performance.

Strike Plates

Use strike plates provided with the locks or latches.

Fire Rated Door closers

Provide closers tested and certified for use as components of fire door assemblies.

Door Controllers Performance

Provide door controllers, including door closers, floor or head spring pivots which are suitable for the door type, size, weight and swings required and the operating conditions, including wind pressure.

## Execution

### Frames

#### General

Install doors so that the frames:

Are plumb, level and straight within acceptable building tolerances.

Are fixed or anchored to the building structure to resist the wind loading.

Will not carry any building loads, including loads caused by structural deflection.

Allow for thermal movement.

#### Flashing and Weathering

Install moulds, sealant and cement pointing as required so that water is prevented from penetrating the building between the door frame and the building structure.

#### Aluminium frames

Building in to masonry: Screw galvanized steel brackets twice to jambs and build in.

Fixing to masonry openings: Use proprietary expansion anchors and screw through jambs at each fixing.

#### Frame Fixing

Brackets: Metallic-coated steel:

Width:  $\geq 25$  mm.

Thickness:  $\geq 1.5$  mm.

Jamb fixing centres:  $\leq 600$  mm.

#### Fixing and Fasteners

Materials: Use materials compatible with the item being fixed and of sufficient strength, size and quality to perform their function.

Concealed fixings: Provide a corrosion resistant finish.

Exposed fixings: Match exposed fixings to the material being fixed.

Support: Provide appropriate back support (for example blocking and backing plates) for hardware fixings.

Packing: Pack behind fixing points with durable full width packing.

Prepared masonry openings: If fixing timber door frames into existing prepared openings with fastenings through the frame face, make the fastener heads finish below the surface and fill the hole for a smooth surface finish.

#### Joints

Make accurately fitted tight joints so that neither fasteners nor fixing devices such as pins, screws, adhesives and pressure indentations are visible on exposed surfaces.

#### Operation

Ensure moving parts operate freely and smoothly, without binding or sticking and are lubricated.

#### Supply

Deliver door hardware items, ready for installation, in individual complete sets for each door.

In a separate dust and moisture proof package labelled for the specific door.

Including the necessary templates, fixings and fixing instructions.

Refer to the drawings and **Flush doors, Joinery doors, PVC doors, Security screen doors, Fire and smoke resistant doorset** and **Automatic door schedules** for details of frames, doors and hardware.

## Completion

### Cleaning

The Contractor is to clean all frames, doors, glass, hardware at completion. Any damage to frames and doors, or broken glass is to be repaired or replaced to the satisfaction of the Engineer.

### Adjustment

Leave the hardware properly adjusted with working parts in working order and lubricated where appropriate.

Verify that plastic products to be incorporated into the project are labeled in accordance with ASTM D 1972. Where products are not labeled, provide product data indicating polymeric information in Operation and Maintenance Manual.

#### PVC Doors Materials

Provide PVC, reinforcing members, fasteners, hardware, weathers tripping, and anchors conforming to AAMA/WDMA/CSA 101/I.S.2/A440 or ASTM D 4099 and as specified herein

### 13.2 **Anodized PVC Works**

#### 13.2.1 Measurement

Measurement of acceptably completed works of anodized PVC doors will be made on the basis of net actual area in square meter provided and installed in position as shown on drawings or as directed by the Supervisor.

#### 13.2.2 Payment

Payment will be made for acceptable measured quantity of all finished anodized PVC doors on the basis of unit rate per square meter quoted in the Bill of Quantities and shall constitute full compensation for all the works related to the item including all reinforcing / stiffening arrangements.

## **SECTION 6250 - GLAZING**

### **1. SCOPE**

The work under this section of the Specifications consists of furnishing all labour, equipment, tools, appliances, scaffolding and providing in any floor and at any height glass, gaskets, sealants, compound and other materials required for performing all operations in connection with the installation and setting of all types of glass and glazing complete in every respect in accordance with the Drawings or as directed by the Supervisor. The scope of this section of Specifications is covered with detailed Specifications as laid down herein.

### **2. APPLICABLE STANDARDS**

Latest editions of following British Standards are relevant to these Specifications wherever applicable.

#### **2.1 BSI (British Standards Institution)**

952 Glass for glazing

5051 Security glazing part I & II

CP.152 Glazing

### **3. GENERAL**

3.1 Each type of glass shall have the manufacturer's label on each pane, and the labels shall remain on the glass until final cleaning.

3.2 Glazing sealant shall be as recommended by the manufacturer for the particular application.

3.3 Spacer shims (distance pieces) shall be plasticized polyvinyl chloride (PVC). Thickness shall be equal to space shown on drawings between glass and rebates bead or cleat. Depth shall give not less than 6mm cover of glazing sealant.

3.4 Contractor shall submit samples for each type of glass, minimum 1.20 x 1.20 m in size with protective edges. Samples of glazing sealant minimum 0.1 liter of specified types shall be submitted.

3.5 Contractor shall submit 1 feet long sample of each type of glazing gasket.

3.6 Contractor shall also submit printed materials manufacturer's installation instructions for specified glazing gaskets, compounds sealants and accessories including description of required equipment and procedures and precautions to be observed.

### **4. DELIVERY STORAGE AND HANDLING**

4.1 Contractor shall deliver materials in manufacturer's original, unopened containers clearly labeled with manufacturer's name and address, material, brand, type, class and rating as applicable.

4.2 Contractor shall store the materials in original unopened containers with labels intact/protected from ground contact and from elements which may damage glass.

4.3 Contractor shall handle the materials in a manner to prevent breakage of glass and damage to surfaces.

## 5. MATERIALS

### 5.1 General

Glass shall be free from all blemishes, bubbles, distortions and other flaws of any kind and shall be properly cut to fit the rebates so as to have a uniform clearance of 1.6 mm round the panes between the edges of glass and the rebates. All glass shall be best quality from reputable manufacturer as approved by the Supervisor.

### 5.2 Glass

Glass for doors and windows shall be imported tinted glass 5mm thick of best quality available in the country approved by the Supervisor. Clear glass to be provided in internal wooden doors shall be clear glass 5 mm thick of local origin. This shall comply with BS 952. PVB (Poly Vinyl Butyral) laminated glass consist of a tough plastic inter layer in between two sheet glass which behave as a single unit and looks like normal glass.

Note that the Drawings required a dual-pane or two-glass glazing system. All glazing products shall conform to this requirement.

### 5.3 Glazing Sealants and Compounds

Contractor shall provide material coloured to match frame in which glass is installed. Provide only compounds known to be fully compatible with surfaces, which they will contact as follows.

5.3.1 Two component polysulfide glazing sealant.

5.3.2 One component acrylic glazing sealant.

5.3.3 Acrylic-latex glazing sealant consisting of modified latex rubber and acrylic emulsion, non-hardening, non- staining and non-bleeding.

5.3.4 Cleaners, Primers and sealer as recommended by the sealant manufacturer.

### 5.4 Accessories

#### 5.4.1 Glazing Sealant

It shall be tape or ribbon of polymerized butyl or mixture of butyl and polyisobutylene compounded with inert fillers and pigments, solvent based 95 percent solids thread or fabric reinforced, paintable, non- staining.

#### 5.4.2 Setting Blocks

It shall be Neoprene 70 to 90 durometer hardness, compatible with sealant used, channel shaped and of the necessary height for proper perimeter clearance.

5.4.3 Channels, Gaskets, and spacer's

It shall be Neoprene, 40 to 50 durometer hardness compatible with sealant used.

6. INSTALLATION OF GLAZING

- 6.1 Glazing shall comply with the recommendations contained in the "MANUAL of GLAZING" of the Glass Marketing Association or as specifically recommended otherwise by the glass and glazing materials manufacturers.
- 6.2 Examine each piece of glass and discard and replace glass with edge damage or face imperfection. All glazing shall be wind tight and fully water tight on completion.
- 6.3 Clean glazing channels and other framing members indicated to receive glass. Remove coatings which are not firmly bonded to the substrate, Remove lacquer from metal surfaces wherever elastomeric sealants are to be used. Apply primer and sealer to joint surfaces wherever recommended by the sealant manufacturer and as shown on the drawings.
- 6.4 Trim and clean excess glazing materials from surrounding surfaces immediately after installation and eliminate stains and discolorations.
- 6.5 Cure glazing sealants and compounds in compliance with manufacturer's instructions to obtain high early bond strength internal cohesive strength and surface durability.
- 6.6 While glazing operation is in progress great care shall be taken to avoid breakage or damage to the glass and adjoining glazing. The Contractor shall make good at his own cost, all glass broken by his workmen while cleaning or carrying out other operations. On the completion of the glazing work, all glass that has been set by the Contractor shall, if it becomes loose, within the maintenance period, be repaired at Contractor's expense.
- 6.7 No glazing shall be considered complete until and unless paint and other stains have been removed from the surface of the glass and checked by the Supervisor for water tightness.

7. PROTECTION AND CLEANING OF GLAZING

- 7.1 Remove all smears, labels and excess glazing sealant, leave clean inside and outside free from scratches. The Contractor shall be responsible for the protection of installed glass. Before final acceptance, damaged or broken glass shall be removed and replaced with new glass at no additional expense to the Employer.
- 7.2 All glass surfaces shall be washed clean both inside and outside within two weeks prior to final acceptance by the Employer.

8. MEASUREMENT AND PAYMENT

No payment shall be made for the works involved within the scope of this section of specifications unless otherwise specifically stated in the Bill of Quantities or herein. The cost there of shall be deemed to be included in the quoted unit rate (square meters of installed area including frame) of

the relevant item of the Bill of Quantities. Area of Windows used in Bill of Quantities for payment of complete installation includes the frame of all windows. Payment for this item will only be made for complete and accepted installation.

## **SECTION 6411 - WATERPROOFING & BUILT-UP ROOFING**

### **1. SCOPE**

The work under this section of the Specifications consists of furnishing all plant, labour, equipment, appliances and materials and in performing all operations in any floor and at any height in connection with installation of insulation, water-proofing and built-up roofing, including water proof treatment to foundations and basement structures complete in strict accordance with this section of the specifications and the applicable drawings and subject to the terms and conditions of the Contract.

Note: The local, acceptable equivalent of “water-proofing and built-up roofing” is called “Isogam”. This material is a composite tar paper and foil layer. It comes in rolls about 1 meter wide and the seams must be made using the heat-welding equipment recommended by the manufacturer for the specific application. The term “Isogam” is used on the Drawings and refers to this material. The term “Isogam” may be used interchangeably with the terms “waterproofing and built-up roofing” in this section.

### **2. SUBMITTAL**

2.1 Shop Drawings: Shop drawings shall be submitted showing layout and all the details for construction.

2.2 Samples of all materials proposed for use under this section, shall be submitted to the Supervisor for approval.

### **3. MATERIALS – see Note above for ISOGAM material.**

3.1 Bitumen 10/20 grade shall be according to BSS.

3.2 Bitumen priming oil shall be of the approved manufacturer.

3.3 Polyethylene building film visqueen standard or approved equal. The film shall be 150 micron thick.

3.4 Cement and aggregates shall be in accordance with specifications for "Plain and reinforced concrete".

3.5 Water proofing agent shall be in accordance with specifications or as desired by the Supervisor.

3.6 Polyurethane spray shall be as per manufacturer's specifications.

3.7 Expanded Polystyrene (Thermopore) shall have a density of not less than 25 kg/m<sup>3</sup>.

3.8 Gravel or Crushed Stone for the roofing system: This material is placed on top of the Isogam roofing material to prevent shrinkage and movement of the Isogam. The size of the gravel for this application shall be 9-10 mm.



#### 4. DELIVERY STORAGE AND HANDLING

Materials shall be protected from damage during loading shipment delivery and storage Non-staining materials shall be used for blocking and packing.

#### 5. PREPARATORY WORK

5.1 All scuppers and roof drains shall be placed and metal flashing flanges etc. shall be provided in time to be installed along with the roofing assembly.

5.2 All surfaces, to be treated shall be dust free and dry. Application of roof finishes shall not start unless the preparatory work has been inspected and approved by the Supervisor.

#### 6. APPLICATION OF ROOFING

6.1 Roofing shall not be applied during rain or while surfaces are damp, it shall be applied only to surfaces that are clean and dry.

6.2 Mopping of surface with bitumen shall be performed so that the surface shall be completely covered. Coats of bitumen shall be as specified in drawings. All bitumen shall be applied with mops except that the hot surfacing application shall be poured from a dipper.

6.3 Polyethylene sheet shall be laid in position wherever shown in drawings. Where joint is necessary at the side or end of the sheet, this shall be a double weld folded joint made by placing the edges together and folding over twice continuously taking the top edge prior to plastering or screeding. The Contractor shall protect the sheets from damages during laying and subsequent operation and shall replace at his own cost all damaged sheets to the satisfaction of the Supervisor.

6.4 Thermopore (expanded polystyrene) shall be laid in places as designated on drawings or as directed by the Supervisor.

#### 7. WATER PROOFING & BUILT UP ROOFING

The water proofing treatment to reinforced cement concrete roof slabs shall be done in the following manner as indicated on the drawings or as directed by the Supervisor.

7.1 50 mm thick polyurethane spray.

7.2.1 The water proofing treatment to reinforced cement concrete roof slab shall consist of 76 mm thick (avg.) class 'C' cement concrete screed steel trowelled finish laid in panels and slope mixed with approved water proofing agent.

7.2.2 The Drawings specify the use of ISOGAM material, which is a composite of tar paper, tar layer and a foil layer. This material is laid down with the foil side facing the interior of the building. The seams, where the sheets of the ISOGAM meet, must be sealed using the equipment and technique required by the manufacturer.

#### 8. WATER PROOFING TREATMENT IN FOUNDATIONS AND SURFACES IN CONTACT WITH EARTH

All surfaces to be bitumen painted shall be thoroughly cleaned of any accretion, dust, dirt etc. by scraping, wire brushing or as directed by the Supervisor. The surface shall be primed with a coat or asphalt oil used at the rate of not less than 4.54 Lit /9.30 square m. Two coats of hot bitumen paint shall be applied at the rate of 18 Kg/9.30 Sq. each coat. The first coat shall be allowed to dry for about 6 hours before applying the second coat. During operation of painting great care shall be taken to avoid air bubbles. The manufacturers shall be taken to avoid air bubbles. The manufacturer's instructions and Supervisor's directions shall be followed.

9. EXPANSION JOINT FILLING

Before filling of Expansion Joint the surface shall be thoroughly cleaned and filling/packing material removed upto a depth of 50 mm. Backer Rod shall then be inserted throughout the length of joint and pressed in. The joint shall then be sealed with 2 part polysulphide sealant.

10. MEASUREMENT AND PAYMENT

10.1 General

Except otherwise specified herein or elsewhere in the Contract Documents, no measurement and payment will be made for the under mentioned specified works related to the relevant items of the Bills of Quantities. The cost thereof shall be deemed to have been included in the quoted unit rate of the respective items of the Bills of Quantities.

The rates quoted by the Contractor in the Bill of Quantities shall include work to be executed under these specification in any floor and at any height except where otherwise specifically stated in the relevant item of Bill of Quantities and the Contractor shall not be entitled to any claim or claim any compensation on this account.

10.1.1 All preparatory work, scrapping, scratching, cleaning, cant strips, gravel strips, etc.

10.1.2 Formwork

10.1.3 Roof treatment including Class 'C' cement concrete and curing.

10.1.4 Coats of bitumen.

10.1.5 Polyethylene sheet including laps/overlaps and joints and Thermopore sheets.

10.1.6 Class 'C' cement concrete cant strip.

10.1.7 Backer rod/2 part polysulphide sealent & Thermopore sheet filling (where ever required) in expansion joint filling.

10.1.8 Water proofing at the vertical sides of masonry walls & RCC beams.

10.2 Water Proofing & Built-up Roofing

10.2.1 Measurement

Measurement of acceptably completed works respective type of water proofing & built-up roofing over will be made on the basis of net actual horizontal superficial area in square meter as shown on the Drawings or as directed by the Supervisor.

10.2.2 Payment

Payment will be made for acceptable measured quantity of respective type of water proofing & built-up roofing on the basis of unit rate per square meter quoted in the Bills of Quantities and shall constitute full compensation for all the works related to the item.

10.3 Bitumen Painting/Coating

#### 10.3.1 Measurement

Measurement of acceptably completed works of bitumen painting/coating will be made on the basis of net actual area in square meter as shown on the Drawings or as directed by the Supervisor.

#### 10.3.2 Payment

Payment will be made for acceptable measured quantity of bitumen painting/coating on the basis of unit rate per square meter quoted in the Bills of Quantities. The unit rate shall include all cost of surface preparation and shall constitute full compensation for all the works related to the item.

### **SECTION 6521 - CEMENT PLASTER**

#### 1. SCOPE

The work under this section of the Specifications consists of furnishing all plant, labour, equipment, appliances, and materials and in performing all operations in any floor and at any height connection with providing and installation of cement plaster, and specified external rendering complete in strict accordance with this section of the Specifications and the applicable drawings and subject to the terms and conditions of the Contract.

#### 2. GENERAL

2.1 Except as may be otherwise shown on surfaces specified, all plaster work, both internal and external shall be ordinary Portland Cement plaster of the required thickness as shown on the drawings.

2.2 Plastering shall not commence until all electric conduits, drainage and sanitary pipes, inlets to tanks, brackets, clamps, doors and window frames and all sorts of inserts and embedded items are fixed in position. It shall be the responsibility of the Contractor to make sure that all such work is carried out by other contractors before starting of plaster work. Chiselling and repairing of cement plaster shall not be permitted without the approval of the Supervisor.

2.3 Sample of materials shall be submitted to the Supervisor for his approval prior to use in the works.

#### 3. MATERIAL

3.1 Cement for plaster shall be Ordinary Portland Cement (B.S 12 or P.S 232) or Sulphate resisting cement (B.S 4027 or P.S. 612) as specified and shall conform to requirements specified in the section "Plain and Reinforced Concrete".

3.2 Sand for plaster shall comply with the requirements of BS 1199, BS 1200 or the draft Pakistan Standard "Sand for Plaster" as directed by the Supervisor.

3.3 Water for plaster shall conform to requirements specified in the section for "plain and reinforced concrete".

3.4 All materials and workmanship for plaster, not explained in these Specifications, shall comply with the requirements of relevant BS CP 211 and CP 221 as directed by the Supervisor.

#### 4. PROPORTIONING AND MIXING

- 4.1 Measurement of materials by volume shall be by containers of known capacity to maintain consistent proportions. No lumpy or caked material shall be used. Mixing equipment boxes and tools shall be clean. Materials shall be proportioned as specified on the Drawings, in the Bill of Quantities or as directed by the Supervisor. Mixing shall be continuous until all ingredients are evenly distributed and thoroughly mixed.
- 4.2 Only limited water shall be added for proper workability and such quantity of mortar shall be prepared which can be consumed in thirty minutes after preparation. Preparation of mortar in bulk quantity for use during the entire day or for any other time more than that stipulated above is expressly prohibited. Retempering shall not be permitted and all mortar which has begun to stiffen shall be discarded.
- 4.3 Plaster ingredients shall be thoroughly mixed either by hand on a clean cement concrete platform or by a mechanical mixer, as directed by the Supervisor.

## 5. PREPARATION OF SURFACE TO BE PLASTERED

- 5.1 Concrete surface to be plastered shall be cleaned to remove all grease, form oil and other surface impurities, which will otherwise adversely affect the adhesion of plaster to the surface concerned. The surface of all-concrete ceilings, beams and columns shall be lightly hacked by approved means to give the required key for plastering.
- 5.2 All masonry surfaces to be plastered shall be cleaned to remove all matter, which will otherwise adversely affect the adhesion of plaster to the surface concerned. The surface shall be washed with clean water and kept damp for 24 hours before further treatment. The surface thus prepared shall be treated uniformly with cement and sand slurry. The slurry to be used shall be one part cement to one part sand by volume with water added to make a stiff creamy mix. The slurry shall be applied with a stiff brush on surface, which has previously been well wetted. The surface so treated shall be left to cure for 3 days.

## 6. APPLICATION OF PLASTER

- 6.1 The plaster of thickness less than the specified thickness shall be rejected. If the plaster is to be more than 1/2" thick, it shall be done in two coats. The surface of first coat shall be made rough before the second coat is applied.

The plaster shall not have wavy surface and shall be perfectly in plumb. The edges and corners shall represent a straight line. The plaster shall be kept wet continuously for at least ten (10) days. No extra payment shall be allowed for jambs, junctions, corners, edges, round surfaces or for more than one layer of plaster required due to any unevenness in the work done by the Contractor. The plasterwork is to cover all conduits, pipes etc fixed in the walls and ceiling. Wherever specified, metal lath shall be nailed firmly before plastering is commenced. The plaster surface shall be tested frequently with a 10 feet straight edge and plumb bob.

- 6.2 Plaster containing cracks, blisters, pits, discolouration or any defects shall not be acceptable. Any such plaster or loose plaster shall be removed & replaced with plaster in conformity with these specifications and as additionally directed by the Supervisor.

Contractor shall cut out and patch all defective work at his own cost. All damaged plaster shall be patched as directed by the Supervisor. Patching plaster shall match appearance of and shall be finished level with adjoining plaster.

## 7. METAL LATH

Metal lathing shall be fabricated from sheet steel and shall be of uniform quality and free from flaws broken strands, cracks and corrosive pitting, shall be rectangular and true to shape and shall comply with BS-1369.

All lathing shall be galvanized. Where plastering material depends entirely on the lathing for its key, these shall be not less than two complete mesh openings per 28 mm in one direction and the width of the aperture shall not be less than 5mm.

Sheets shall not be less than 1.6 kg/sq.m when fabricated, using 0.7 mm thick steel sheet. Where used on smooth surfaces to form a key it shall be not less than 1.2 kg/sq.mm when fabricated, using 0.5 mm thick steel sheet. Tying wire shall be 1.2 mm diameter galvanized annealed iron wire.

Sheets shall be welded to angle iron frame as shown on drawings.

## 8. ANGLE AND BEADS

Angle beads, stop beads, depth gauge beads, edging profiles, plaster dividing profiles, interior angle profiles, plaster borders and the like shall all be manufactured from sheet steel and galvanized after fabrication, all beads shall be perforated at edges to ensure good adhesion of the plaster work. Thickness and dimensions shall suit particular locations and plaster thickness.

All angle beads, stop beads, depth gauge beads and the like are to be fixed in accordance with the manufacturer's instructions, at all corners, stops, joints, etc. as per directions of Supervisor In-charge.

## 9. INTERNAL/EXTERNAL PLASTER

9.1 Where specified in the Drawings external surface shall have an average 15-20 mm thick plaster finish, consisting of a base coat of 1:4 cement sand mortar in Grey cement and the finish coat of smooth plaster as shown on the Drawings and as directed by the Supervisor.

9.2 Where specified in the Drawings all internal plaster shall have an average 12 mm thick 1:4 cement sand mortar in grey cement of smooth plaster as shown on the Drawings and as directed by the Supervisor.

9.3 Stucco / Textured Plaster

Wherever specified in the drawings external stucco plaster shall consist of 1:2, one part white cement & 2 parts approved shade of marble chips zero size mixed with approved pigment to achieve desired shade. Wherever shown on drawings, groves shall be provided with aluminium U/Y channels. The contractor shall prepare mockup samples of stucco plaster for the approval of Supervisor. The plaster shall be applied with machines and the final rough surface/texture/shade shall be as per the approved sample, direction and approval of the Supervisor.

## 10. CLEANING AND PROTECTION

10.1 Rubbish and debris shall be removed as necessary to make way for work of other trades and as directed by the Supervisor. As each room or space is completed all rubbish, debris, scaffolding and tools should be removed to leave the room clean.

10.2 Prior to plastering all aluminium windows, finished metals should be covered by sheet of plastic or tarpaulin to protect it from damage.

10.3 Protect finished plaster from injury by any source. Contractor shall also protect walls, floors and work of other trades from plaster materials.

## 11. TOLERANCES

Surfaces of plaster work shall be finished with a true plane to correct line and level with all angle and corners to a right angle unless otherwise specified and with walls and reveals plumb and square.

Maximum permitted tolerances shall not exceed 1/8" in 6 feet variation from plumb or level in any exposed line or surface and 1/16" variation between planes of abutting edges or ends.

## 12. MEASUREMENT AND PAYMENT

### 12.1 General

Except otherwise specified herein or elsewhere in the Contract Documents, no measurement and payment will be made for the under mentioned specified works related to the relevant items of the Bill of Quantities. The cost thereof shall be deemed to have been included in the quoted unit rate of the respective item of the Bill of Quantities.

The rates quoted by the Contractor in the Bill of Quantities shall include work to be executed under these specification in any floor and at any height except where otherwise specifically stated in the relevant item of Bill of Quantities and the Contractor shall not be entitled to any claim or claim any compensation on this account.

12.1.1 Metal lath over reinforced concrete and masonry joint.

12.1.2 Joints, junctions, corners, beads, drip course edge, roundings, and aluminium U/Y channels in grooves. Etc.

12.1.3 More than one layer due to any unevenness in the finished works and base coat plaster in stucco plaster including marble chips/colour pigments.

12.1.4 Cutting & patching of all defective works.

12.1.5 Surface preparation, cleaning and protection as specified.

12.1.6 Marble chips & pigments in stucco plaster/Textured plaster.

12.1.7 Roughening of first coat of plaster before application of 2<sup>nd</sup> coat in case where overall required plaster thickness exceeds ½ inch.

12.1.8 Water proofing agent to be used for water proof plaster.

12.1.9 Rough base plaster

### 12.2 Plain Plaster/Water Proof Plaster/Textured Plaster

#### 12.2.1 Measurement

Deductions shall not be made for ends of joints, beam posts, etc., and openings less than 1 square meter each and no addition shall be made for reveals, jambs, soffits, sills, etc. of these openings non for finishing the plaster around ends of joints, beams posts, etc.

In case of opening of area including exceeding 1.0 square meter each, deduction shall be made for the openings and also no addition shall be made for reveals jambs, soffits, sills, etc., of these openings.

Measurement of acceptably completed works of plaster will be made on the basis of number of square meter of the surface area plaster as shown on the Drawings, or as directed by the Supervisor.

#### 12.2.2 Payment

Payment will be made for acceptable measured quantity of plaster on the basis of unit rate per square meter quoted in the Bill of Quantities and shall constitute full compensation for all the works related to the item.

### **SECTION 6531- MARBLE**

#### 1. SCOPE

The work under this section of specifications, consists of providing all material, labour, plant, equipment, appliances in any floor and at any height and performing all operations required for providing and installing marble natural stone slab for toilet counters, where shown on the drawings, complete in strict accordance with this section of the specification and the applicable Drawings.

#### 2. SUBMITTALS

The Contractor shall submit manufacturer's specifications and other product data for each type of marble stone and fixtures required, including instructions for handling, storage, installation and protection.

Shop Drawings shall be submitted showing sizes, dimensions, sections and profiles of slab, arrangement and provisions for jointing, anchoring, fastening and supports and other necessary fixing details. Indicate locations, layouts and pattern arrangements for each stone type and colour.

Submit three ranges samples 300mm x 300mm in size of each type of stone showing colour, grade, finishing and texture for approval of the Supervisor.

#### 3. DELIVERY, STORAGE AND HANDLING

Materials shall be protected from damage during loading, shipment, delivery and storage. Non-staining materials for blocking and packing shall be used. Stack marble at site in accordance with manufacturer's recommendations and as required to prevent staining, scratching, etching or breakage.

#### 4. MATERIALS

##### 4.1 General

Marble shall be compact, dense, metamorphic rock of lime stone origin obtained from quarries within Pakistan. It shall have a specific gravity of 2.7 and hardness number on Moh's scale shall range from 3 to 4.

Obtain each marble stone type from a single quarry and ensure consistent colour range and texture throughout the work. All pieces shall be of uniform thickness and truly square in shape.

Provide marble slabs/sills and tiles of specified sizes in floors, stair tread & risers and counter tops as shown on drawings.

Provide marble slabs/sills and tiles of type, colour and finish for each area as directed by the Supervisor.

Provide stone of specified thickness. Saw cut the back surfaces that are meant to be concealed in finished work.

Provide irregular shaped units, staircase units and skirting base units to the profiles of required shapes & sizes and polished exposed surfaces wherever specified.

#### 4.2 Marble Stone Type

All marble stone types are to be selected and approved by the Supervisor for quality, colour and texture.

Marble: Marble of approved type and colour of local origin, first class quality and high class finish acceptable to the Supervisor.

#### 4.3 Beds and Backings

Where applicable, standard cementitious screed and mortar beds and backings, mixed and proportioned by volume shall be as follows: -

Grey ordinary	
Portland Cement	: 1 part
Sand	: 2 parts
Water	: Clean, fresh and free from Deleterious substances

#### 4.4 Adhesives, Grouts and Sealants

Proprietary adhesives, joint grouts and sealants of approved type as required and recommended by the manufacturer for specific application shall be used. The colour of the joint grout and the sealants shall match with the colour of stone.

### 5. EXECUTION

#### 5.1 Flooring, Skirting/dado and Stair

Apply cement slurry coat over surfaces of concrete substrate immediately prior to placing setting bed. Limit area of application to avoid premature drying out. Install setting bed of required thickness and set stone units before initial set occurs. Apply a thin layer of cement



paste to bottom of each unit. Set tamps and level units immediately. Set units in required pattern with uniform joint widths.

Point joints as soon as possible after initial set. Force grout into joints, strike flush and tool slightly concave.

Remove mortar and grout from surfaces while still moist and as the work progresses.

Do not permit traffic on finished surface during setting and for a minimum of 24 hours after final pointing of joints.

## 5.2 Marble Toilet Counters

Marble toilet counter tops of the specified size shall be installed in areas shown on Drawings with M.s. angle framing and fixing accessories in accordance with approved shop drawing. Joints shall be cement grouted with matching colour or with matching colour sealant.

## 5.3 Repair and Cleaning

Remove and replace stone units which are broken, chipped, stained or otherwise damaged. Where directed, remove and replace units which do not match adjoining stonework or are not in line and level as shown on Drawings. Provide new matching units, install and point joints to eliminate evidence of replacement. Repoint defective and unsatisfactory joints to provide neat, uniform appearance.

Clean stonework not less than 6 days after completion of work, using clean water and bristle brushes. Do not use wire brushes, acid or caustic type cleaning agents or other cleaning compounds which may be detrimental to the stone finish or joint grout.

## 5.4 Protection

Provide covers, boards, supports and all other necessary materials to protect finished work from collapse, deterioration, discolouration or damage during installation and until contract completion.

## 5.5 Polishing

The finished surface shall be chemically polished, acceptable to the Supervisor.

# 6. MEASUREMENT AND PAYMENT

## 6.1 General

Except otherwise specified herein or elsewhere in the Contract Documents, no measurement and payment will be made for the under mentioned specified works related to the relevant items of the Bill of Quantities. The cost thereof shall be deemed to have been included in the quoted unit rate of the respective items of the Bill of Quantities.

The rates quoted by the Contractor in the Bill of Quantities shall include work to be executed under these specification in any floor and at any height except where otherwise specifically stated in the relevant item of Bill of Quantities and the Contractor shall not be entitled to any claim or claim any compensation on this account.

- 6.1.1 Finishing, washing, polishing, repair cleaning and protection of marble stone/tiles in position.
- 6.1.2 Proprietary adhesives, joint grouts and sealants for fixing marble stone where specified on the Drawings or directed by the Supervisor.
- 6.1.3 Class 'C' cement concrete screed bed and 1:2 cement sand mortar for marble stone/tiles in floors, skirting, steps, etc.
- 6.1.4 Preparation of concrete substrate for laying marble sills/slabs and tiles.
- 6.1.5 M.S. angle framing and fixing accessories for marble counters.
- 6.1.6 Chemical polishing on marble surfaces.

6.2 Marble Tile floor / skirting/Stair Steps/Vanity Top

6.2.1 Measurement

Measurement of acceptably completed works of marble tile floor / skirting/ Stair Steps/ Vanity Top will be made on the basis of net actual area in square meter of marble floor / skirting/ Stair Steps/ Vanity Top provided and installed in position as shown on the Drawings or as directed by the Supervisor.

6.2.2 Payment

Payment will be made for acceptable measured quantity of marble floor / skirting /Stair Steps/ Vanity Top on the basis of unit rate per square meter quoted against respective item in the Bills of Quantities and shall constitute full compensation for all the works related to the item.

**SECTION 6560 - FALSE CEILING**

**1. SCOPE**

The work under this section of the specifications, consists of furnishing all plant, labour, equipment, appliances and materials in any floor and at any height and in performing all operations in connection with providing and installing different types of false ceiling including suspension system complete, in strict accordance with this section of the specifications and the applicable drawings and subject to the terms and conditions of the Contract.

**2. GENERAL**

False ceiling shall be installed wherever indicated on the drawings by skilled technicians experienced in this type of work. Installation shall not commence in any room or space before completion of plasterwork on structural roofing/internal walling/external surfaces.

**3. MATERIALS**

3.1 Tiles

Tiles shall be of approved size, shape and colour as shown on drawing or as approved by the Supervisor shall be used.

All four edges shall be revealed to be installed by an approved recessed suspension system, strictly in accordance with the approved shop drawings, manufacturer's recommendations or instructions of the Supervisor.

### 3.2 Aluminium Strips

Aluminum strip ceiling shall be aluminum 4 inches wide strips, plain surfaced, with mineral wool insulation, manufactured by DAMPA (Denmark) or DAIKEN (Japan).

### 3.3 Suspension System

The suspension system for all types of false ceiling shall be in accordance with the recommendations of the approved false ceiling manufacturer and approved shop drawings, consisting of aluminium universal U-channels/ main T/Cross-T Bars, wall mouldings/ edge trims, hold down/adjustment clips, galvanized hanger strips with adjustment mechanism, etc.

## 4. SUBMITTALS

4.1 Shop drawings shall be submitted showing reflected ceiling plan, locations of built in products and access facilities, dimensions, layout arrangements, hanger locations, structural connection, details of level changes, direction of pattern and panel joint details. The shop drawings shall be got approved by the Contractor from the Supervisor in advance of under taking this item of works.

4.2 No materials shall be procured prior to approval of shop drawings and details.

4.3 The Contractor shall incorporate the required access panels of false ceiling as per approved shop drawings.

## 5. PRODUCT DELIVERY, STORAGE AND HANDLING

5.1 Material shall be delivered in original, unopened, protective packaging, with manufacturer's labels indicating brand name, pattern, size, thickness and fire rating.

5.2 Material shall be stored in original protective packaging to prevent soiling, physical damage or wetting.

5.3 Cartons shall be stored in the installation area, opened at each end to stabilize moisture content and temperature, for 48 hours prior to installation.

## 6. JOB SITE CONDITIONS

6.1 Work which will be concealed by false ceilings shall be completed, tested, inspected and accepted before ceiling work is started.

6.2 False ceiling installation shall not begin until the area has been closed in, and temperature and humidity approximate occupancy conditions. Wet work shall be cured and dry before ceiling work is started.

6.3 Surface which will support the ceilings, and those to which the ceiling abut, shall be inspected and accepted for completeness and adequacy to receive the ceilings before the work begins.

## 7. INSTALLATION AND WORKMANSHIP

False ceiling suspension system and panels shall be installed in accordance with the requirements of BSI-CP.290 and with the manufacturer's recommendations as approved by the Supervisor.

#### **7.1 Suspension System**

The hangers as specified shall be evenly disposed as per drawings, details and place and position as indicated. The suspension system should be installed by making holes directly in the roof and shall be made good as directed by the Supervisor. Their lengths clear of roofing slab shall be as per shop drawing details.

The framing of the specified section and run at spacing as per shop drawings. The jointing of runners to hangers shall be as per approved shop drawing details. The extra framing if required shall be provided for light receptacles as per approved shop drawing details.

Wall hangers shall be positively and rigidly connected to the structure and to cross runners.

#### **7.2 False Ceiling tiles.**

Tiles shall be installed in the grid system after completion of installation of the suspension of lighting and air conditioning fixtures.

Forming ceiling panels shall be laid out in pattern including border of uniform width around all sides of each ceiling area. The pattern shall be as per shop drawings approved by the Supervisor.

All panels shall be furnished and installed in an approved manner and as per approved types, sizes and surface design.

### **8. FIXTURES**

Light fixtures shall be installed as per approved pattern and supported in accordance with manufacturer's recommendations.

### **9. FINISHING**

After installation, dirty, soiled or discolored surfaces shall be cleaned and left free from defects and ready to receive any painted finish if required.

The panels which are damaged or improperly installed shall be removed and replaced by the Contractor at his cost.

### **10. MEASUREMENT AND PAYMENT**

#### **10.1 General**

Except otherwise specified herein or elsewhere in the Contract Documents, no measurement and payment will be made for the under mentioned specified works related to the relevant items of the Bill of Quantities. The cost thereof shall be deemed to have been included in the quoted unit rate of the respective items of the Bill of Quantities.

The rates quoted by the Contractor in the Bill of Quantities shall include work to be executed under these specification in any floor and at any height except where otherwise

specifically stated in the relevant item of Bill of Quantities and the Contractor shall not be entitled to any claim or claim any compensation on this account.

Aluminum approved suspension system including main channels, main tee/cross tee bars, wall moulding and edge trims, hanger strips and accessories, hold down clips, Aluminum tiles / strips etc. complete for aluminum tile / strips ceiling, scaffolding.

## 10.2 False Ceiling

### 10.2.1 Measurement

Measurement of acceptably completed works of respective types of false ceiling will be made on the basis of net actual area in square meter of false ceiling provided and installed in position as shown on the Drawings or as directed by the Supervisor.

### 10.2.2 Payment:

Payment will be made for acceptable measured quantity of respective type of false ceiling on the basis of unit rate per square meter quoted in the Bill of Quantities and shall constitute full compensation for all the works related to the item.

## **SECTION 6600 - FLOOR AND WALL FINISHES**

### 1. SCOPE

The work under this section of the Specification consists of furnishing all plant, labour, equipment, appliances and materials and performing all operations in any floor, wall, counter and at any height in connection with the installation of cement concrete floors and floor finishes including bases, skirting and external surface treatments, complete in strict accordance with this section of the specifications and the applicable drawings and subject to the terms and conditions of the Contract.

### 2. MATERIAL

#### 2.1 Cement

Cement shall be ordinary Portland cement conforming to B.S. 12 .

#### 2.2 Sand

All fine sand shall be obtained from sources approved by the Supervisor. The grading shall conform to B.S 882 Grading Zone 1 and 2 of which the gradation limits are as follows:

Percentage (by weight) passing

B.S. Sieve	Grading Zone 1	Grading Zone 2
3/8" (9.53 mm)	100	100
3/16" (4.765 mm)	90-100	90-100
No. 7	60-95	75-100
No. 14	30-70	55-90
No. 25	15-34	35-59
No. 52	5-20	8-30
No. 100	0-10	0-10

#### 2.3 Coarse Aggregate

Coarse aggregate shall be crushed or uncrushed gravel or crushed stone, angular or rounded in shape and shall have granular, crystalline or smooth surface free from friable, flaky and laminated pieces, mica and shale. It shall not contain matters injurious to concrete. All coarse aggregate shall conform to BSS NO.882 and shall be graded as follows:

B.S. Sieve	% Passing by weight
1" (25.40 mm)	100
3/4" (19.05 mm)	90-100
3/8" ( 9.53 mm)	20-55
3/16"(4.765 mm)	0-10

The aggregate shall be stored on properly constructed paving or as directed by the Supervisor.

There shall be a physical partition between the stockpiles of coarse and fine aggregate. If required, aggregates shall be washed and screened to the satisfaction of the Supervisor. Sieve analysis of all the aggregates to be used in the works shall be carried out as and when required by the Supervisor. All aggregate shall be subject to the approval of the Supervisor.

Any aggregates not found to be of the specified/approved standard shall be rejected by the Supervisor and all such rejected material shall be removed from site with-out delay.

Floors sub-base or base constructed with rejected aggregates shall be dismantled and rebuilt at the expense of the Contractor.

#### 2.4 Stone Ballast

Stone ballast to be used as soling shall comprise of strong, hard, durable stone of approved size. The stone shall be obtained from approved quarry and shall be sound, free from laminations and weak cleavages and shall conform to specifications of "Stone Soling".

#### 2.5 Water

Water used for mixing concrete, curing or any other operation of the works specified herein shall be fresh, clean and free from organic or inorganic matters in solutions or in suspension. Only water of the approved quality shall be used for all constructional purposes:

#### 2.6 Ceramic/ Porcelain Tiles

Ceramic tiles shall be imported, premium quality, plain white/coloured or printed. Porcelain tiles shall be of premium quality of approved colour. The tiles shall be of sizes as specified on the drawings and shall conform to BS 1281 as per samples.

#### 2.7 Precast Concrete Pavers

Wherever specified on the drawings, precast concrete pigmented pavers manufactured by Envicrete or approved equivalent shall be used.

2.8 Stone tiles for wall Cladding

Stone tiles of approved size, shape and colour shall be used for cladding purpose on the surfaces as specified on drawings.

2.9 Precast Kerbstone

Precast kerbstone of size & shape as shown on the drawings and as directed by the Supervisor shall be used accordingly.

3.0 Marble vanity

Wherever specified on the drawings, pre-polished marble vanity top  $\frac{3}{4}$ " thick (one piece) of approved quality, colour & shade shall be used.

3. CEMENT CONCRETE FLOORING

The materials for C.C flooring shall be same as already specified under clause 3, "Materials".

3.1 Composition of Concrete

Concrete shall be composed of Portland Cement, sand, coarse, aggregate and water, all well mixed and brought to the proper consistency. The Contractor shall mix the ingredients as indicated on the Drawings. The proportions of the various ingredients shall be determined from time to time during the progress of the work and tests shall be made of samples of the aggregates and the resulting concrete. The mix proportions and appropriate water-cement ratio will be determined on the basis of the production of concrete having required workability, density, impermeability, durability and required strength.

3.2 Mixing Concrete

The concrete ingredients shall be mixed in a batch mixer for not less than 1-1/2 minutes after all ingredients, except the full amount of water, are in the mixer. The Supervisor reserves the right to increase the mixing time when the charging and mixing operations fail to produce a concrete batch in which the ingredients are uniformly distributed and the consistency is not uniform. The concrete shall be uniform in composition and consistency from batch to batch except when changes in composition or consistency are required. Water shall be added prior to, during and following the mixer charge. Excessive over-mixing requiring addition of water to preserve the required concrete consistency will not be permitted. The concrete ingredients shall be mixed by volumetric measurement in purpose made boxes approved by the Supervisor.

3.3 Construction

The base course of the floor shall comprise of stone ballast of 2 inches (approx: 50 mm) mesh size. The base course shall be thoroughly compacted by suitable power rammers to the total consolidated thickness as shown on the Drawings and as approved by the Supervisor. The interstices shall be filled with smaller size stones. The base course shall be blinded with sand and the whole surface watered. Over the well compacted base

course, a layer of concrete of the required grade and thickness shall be laid, in panels of the sizes as indicated on the Drawing and as approved by the Supervisor.

After the C.C bed has been cured, as directed by the Supervisor, it shall be roughened and well watered before floor finishing is laid. The floor finish shall comprise of cement concrete of required grade and shall be laid in panels to the required thickness as shown on the Drawings or as directed by the Supervisor. The concrete after laying will be thoroughly rammed and mortar worked up to the top and smoothed with a steel trowel. The edge of each section into which the floor is divided should be defined by wooden screeds of the approved width and of a depth equal to the depth of the floor concrete.

Freshly placed concrete floor and completed floor portions as finished shall be protected to prevent loss of water by covering with damp hessian, water proof paper, damp sand or other approved material, and shall be kept constantly damp for a period of four days or longer after concreting as directed by the Supervisor. The concrete shall be allowed to dry out slowly over a period of three days after wet curing is completed.

The expansion joints shall be filled in with hot bitumen, of the approved grade, as directed by the Supervisor.

#### 4. INSTALLATION OF TILE FLOORING/ WALL CLADDING

When setting out the tiles, care shall be taken to establish the correct elevation for the floor. A gauge rod shall be used, indicating the overall measurement of a given number of tiles with specified joint width to reduce cutting.

After the floor has been machine finished, it should be covered with white, non-staining sand or rags to protect it while other work is being done. After removal, the floor shall be thoroughly scrubbed.

##### 4.1 General

The base shall be prepared by laying cement concrete of specified grade and of thickness as shown on the drawings, or specified in the Bill of Quantities.

The curing period of the setting bed shall be as directed by the Supervisor. As large an area of setting bed shall be spread at one time as can be covered with tiles before the mortar has set. Surplus mortar shall be removed. The thickness of setting bed in any space shall not be less than 1/2".

Floor and wall surfaces to receive the tiles shall be thoroughly cleaned of all dirt, dust, oil and other objectionable matters. Tiles shall be laid out from the centre line of each space in an outward direction and the pattern should be made symmetrical with a minimum number of cut tiles as directed by the Supervisor.

Joints between the tiles shall be of uniform width. Tiles shall be cut with a suitable cutting tool and rough edges shall be rubbed smooth. Tiles shall be laid to the straight edges.

##### 4.2 Ceramic/Porcelain/Stone tiles

The ceramic/ porcelain/ Stone tiles shall be laid to the required lines, levels and grades over a setting bed of cement sand mortar comprising of one part of cement and 4 parts of sand by volume and the joints filled with neat white or grey cement including vertical and



horizontal covers. The tile floor shall be kept wet for at least 72 hours and no traffic should be allowed on the tiles during curing period.

4.3 Porcelain tiles on steps

Porcelain tiles shall be used on treads & risers of steps set over class 'C' concrete base and 1:2/1:3 cement sand mortar base respectively.

4.4 Marble vanity top

Pre-polished marble vanity top  $\frac{3}{4}$ " thick (one piece) of approved quality, colour & shade shall be laid in approved pattern set in 1:2 cement sand mortar base including bull nosing/ chamfering of edges. The surface of holes, made for wash basins, shall be smooth without sharp edges.

4.5 Precast Pavers

Precast pavers of approved colour & size shall be laid in approved pattern over 50mm thick sand cushion. The sub grade consisting stone/brick ballast shall be well compacted.

4.6 Precast Kerb stone

Precast kerb stones of approved shape & size shall be laid over concrete class 'E' on the well compacted sub grad surface.

5. MEASUREMENT AND PAYMENT

5.1 General

Except otherwise specified herein or elsewhere in the Contract Documents, no measurement and payment will be made for the under mentioned specified works related to the relevant items of the Bill of Quantities. The cost thereof shall be deemed to have been included in the quoted unit rate of the respective items of the Bill of Quantities.

5.1.1 Loss and wastage of material due to consolidation, erosion and settlement.

5.1.2 All type of joints (expansion, contraction and construction joint etc.).

5.1.3 Class 'C' cement concrete screed base and 1:2/1:3 cement sand mortar under, floor, wall bases, top of kitchen/vanity counters and skirting/dado etc.

5.1.4 Finishing/grinding, washing, polishing and protection works of ceramic, concrete, porcelain tile floors and marble tiles.

5.1.5 All cement sand ratios for rough base plaster, white cement.

5.1.6 Sand cushion under concrete pavers,

5.1.7 Supply, placing & compaction of stone ballast under floor,

5.1.8 Adhesives used in the laying of tiles.

- 5.1.9 Bedding / Jointing Material of porcelain tiles/ ceramic tiles/ stone tiles.
- 5.1.10 Preparation of concrete substrata for laying sills/slabs, pavers, kerbstone and tiles.
- 5.1.11 M.S. angle framing and fixing accessories for counters.
- 5.1.12 Earth work
- 5.1.13 All types of misc. hardware items needed to complete the job as shown on the drawings.
- 5.1.14 Bull-nozing, chamfering of edges of marble tops including base mortar and making holes/openings including all necessary fixing accessories.

### 5.3 Ceramic/Porcelain Tile Floor

#### 5.3.1 Measurement

Measurement of acceptably completed works of ceramic/porcelain tile in floor will be made on the basis of net actual area in square meter of floor laid in position as shown on the drawing or as directed by the Supervisor.

#### 5.3.2 Payment

Payment will be made for acceptable measured quantity of ceramic/porcelain tile floor on the basis of unit rate per square meter quoted in the Bills of Quantities and shall constitute full compensation for all the works related to the item.

### 5.4 Ceramic/Porcelain Tiles Dado/Skirting

#### 5.4.1 Measurement

Measurement of acceptably completed works of ceramic/ porcelain tile in dado/ skirting will be made on the basis of net actual area in square meter of dado/skirting laid in position as shown on the Drawing or as directed by the Supervisor.

#### 5.4.2 Payment

Payment will be made for acceptable measured quantity of ceramic/ porcelain tile in dado/skirting on the basis of unit rate per square meter quoted in the Bills of Quantities. The unit rate shall include all cost of cement, sand, mortar and shall constitute full compensation for all the works related to the items.

### 5.5 Cement Concrete sub-floor

#### 5.5.1 Measurement

Measurement of acceptably completed works of cement concrete floor will be made on the basis of net actual area in square meter flooring laid in position as shown on the Drawing or as directed by the Supervisor.

#### 5.5.2 Payment

Payment will be made for acceptable measured quantity of cement concrete floor on the basis of unit rate per square meter quoted in the Bills of Quantities. The unit rate shall include all cost of cement, sand, mortar, stone ballast and shall constitute full compensation for all the works related to the items.

5.6 Marble Slab Counter/ Vanity Top

5.6.1 Measurement

Measurement of acceptably completed works of marble slab counter/ vanity top will be made on the basis of net actual area in square meter of slab laid in position as shown on the Drawing or as directed by the Supervisor.

5.6.2 Payment

Payment will be made for acceptable measured quantity of marble slab laid on counter /vanity top on the basis of unit rate per square meter quoted in the Bills of Quantities and shall constitute full compensation for all the works related to the item.

5.7 Reception Counter

5.7.1 Measurement

Measurement of acceptably completed work of reception counter will be made on the running meter basis provided and installed in position as shown on the Drawings or as directed by the Supervisor. It shall include block masonry, marble top, Lasani wood backing, Stainless steel finish Formica laminated on lasani board, S. Steel skirting, wooden gola etc to complete the work as shown on drawing.

5.8.2 Payment

Payment will be made for acceptable provided & fixed reception counter on the basis of unit rate quoted in running meter in the Bill of Quantities. Payment shall constitute full compensation for all the works related to the item.

5.9 Stone tiles

5.9.1 Measurement

Measurement of acceptably completed works of Stone tiles on wall will be made on the basis of net actual area in square meter of tiles laid in position as shown on the Drawing or as directed by the Supervisor.

5.9.2 Payment

Payment will be made for acceptable measured quantity of Stone tiles on walls on the basis of unit rate per square meter quoted in the Bills of Quantities and shall constitute full compensation for all the works related to the item.

5.10 Precast Concrete Pavers

5.10.1 Measurement

Measurement of acceptably completed works of precast pigmented pavers will be made on the basis of net actual area in square meter of pavers laid in position as shown on the Drawing or as directed by the Supervisor.

5.10.2 Payment

Payment will be made for acceptable measured quantity of pavers on the basis of unit rate per square meter quoted in the Bills of Quantities and shall constitute full compensation for all the works related to the item.

5.11 Precast Concrete Kerb stone

5.11.1 Measurement

Measurement of acceptably completed works of precast concrete kerb stone will be made on the basis of net actual length in running meter of kerb stones fixed/laid in position as shown on the Drawing or as directed by the Supervisor.

5.11.2 Payment

Payment will be made for acceptable measured quantity of kerb stones on the basis of unit rate per running meter quoted in the Bills of Quantities and shall constitute full compensation for all the works related to the item.

**SECTION 6700 - PAINTING**

1. SCOPE

The work under this section of the Specifications consists of furnishing all materials, plant, labour, equipment, appliances and performing all operations in any floor and at any height in connection with surface preparation, mixing, painting concrete works, gates, frames, walls, ceilings and all such surfaces as shown on the Drawings and/or as directed by the Supervisor. The scope of this section of specification is covered with detailed specifications as laid down herein.

2. APPLICABLE STANDARDS

Latest editions of following British Standards are relevant to these specifications wherever applicable.

2.1 BSI (British Standards Institution)

245	Specification for mineral solvents (white spirits and related hydrocarbon solvents) for paints and other purposes.
2521	Lead-based priming paint for wood work.
2523	Lead based priming paint for iron and steel.
2569	Sprayed metal coatings.
4800	Paint colours for building purposes.
CP.231	Painting of building.
CP.3012	Cleaning and preparation of metal surfaces.

3. GENERAL

3.1 Except as otherwise specified, all painting shall be applied in conformity with BS CP 231 "Painting of Building" as applicable to the work.

3.2 The Contractor shall repair at his own expense all damaged or defective areas of shop-painted metal work and structural steel work. Metal surfaces against which concrete are to be placed will be furnished shop-painted and shall be cleaned prior to being embedded in concrete.

3.3 Except as otherwise specified all concrete and plastered surfaces are to be painted.

- 3.4 The Supervisor will furnish a schedule of colours for each area and surface. All colours shall be mixed in accordance with the manufacturer's instructions.
- 3.5 Colours of priming coat (and body coat) where specified, shall be lighter than those of finish coat. The Supervisor shall have unlimited choice of colours.
- 3.6 Samples of all colours, and finishes shall be prepared in advance of requirement so as not to delay work and shall be submitted to the Supervisor for approval before any work is commenced. Any work done without such approval shall be redone to the Supervisor's satisfaction, without additional expense to the Employer. Samples of each type of paint shall be on separate 12" x 12" x 1/8" tempered hard board panels. Manufacturer's colour chart shall be submitted for colour specifications and selection.

#### 4. MATERIALS

- 4.1 All materials shall be acceptable, proven, first grade products and shall meet or exceed the minimum standards of reputable manufacturers as approved by the Supervisor.
- 4.2 Colours shall be pure, non-fading pigments, mildew-proof sun-proof, finely ground in approved medium. Colours used on-plaster and concrete surfaces shall be lime-proof. All materials shall be subject to the Supervisor's approval.
- 4.3 All synthetic enamel paints and primers for structural steel works, metal work and Matt enamel for wood works will be the best available of its type and shall be approved by the Supervisor prior to its procurement.
- 4.4 Approved quality Weather Shield/Weather Coat paint shall be used for painting the exteriors of the structures or other surfaces where specified on the drawings as directed by the Supervisor.
- 4.5 The synthetic enamel matt finish paint or similar as approved by the Supervisor shall be used for interior wall & ceiling surfaces.
- 4.6 All material for Bitumen painting shall consist of Bitumen grade 10/20. It shall be used for foundations or wherever recommended by the Supervisor. The rate of application in foundations shall not be less than 5.0 lb/10 Sft. each coat.
- 4.7 All paints to be used shall be got approved prior to place order & usage.

All material shall be delivered to site in their original unbroken containers or packages & bear the manufacturer's name, label, brand & formula & will be mixed and applied in accordance with his directions.

#### 5. DELIVERY STORAGE AND CONTAINER SIZES

Paints shall be delivered to the site in sealed containers, which plainly show the type of paint, colour (formula or specifications number) batch number, quantity, date of manufacture, name of manufacturer and instructions for use. Pigmented paints shall be supplied in containers not larger than 20 liters. All materials shall be stored under cover in a clean storage space, which should be accessible at all times to the Supervisor. If storage is allowed inside the building, floors shall be kept clean and free from paint spillage.

#### 6. SURFACE PREPARATION

- 6.1 All oil, grease, dirt, dust, loose mill scale and any other foreign substance shall be removed from the surface to be painted, polished and white washed by the use of a solvent and clean wiping material. Following the solvent cleaning, the surfaces shall be cleaned by scrapping, chipping, blasting, wire brushing or other effective means as approved by the Supervisor.
- 6.2 In the event the surfaces become otherwise contaminated in the interval between cleaning and painting, re-cleaning will be done by the Contractor at no additional cost.
- 6.3 Surfaces of stainless steel, aluminum, bronze, and machined surfaces adjacent to metal work being cleaned or painted shall be protected by effective masking or other suitable means, during the cleaning and painting operations.
- 6.4 All the surfaces to be painted with approved quality paint shall be free from dust, dirt, fungus, lichen, algae etc. Oil paint, varnish and lime wash should always be removed by scraping and washing.
- 6.5 All surfaces to be bitumen painted shall be thoroughly cleaned of any accretion, dust, dirt etc. by scraping, wire-brushing or as directed by the Supervisor. The surface shall be primed with a coat of asphalt oil used at the rate of not less than 0.50 pound per square foot.

No work in this section shall be allowed until all surfaces or conditions have been inspected and approved by the Supervisor.

## 7. APPLICATION

- 7.1 All paint and coating materials shall be in a thoroughly mixed condition at the time of application. All work shall be done in a workman like manner, leaving the finished surface free from drips, ridges, waves, laps, and brush marks. All paints shall be applied under dry and dust free conditions. Unless approved by the Supervisor paint shall not be applied when the temperature of the metal or of the surrounding air is below 7 degrees centigrade. Surfaces shall be free from moisture at the time of painting.

All primary paint shall be applied by brushing. The first coat of paint shall be applied immediately after cleaning. When paint is applied by spraying, suitable measures shall be taken to prevent segregation of the paint in the container during painting operation.

Effective means shall be adopted for removing all free oil and moisture from the air supply lines of the spraying equipment. Each coat of paint shall be allowed to dry or harden thoroughly before the succeeding coat is applied. Surfaces to be painted that will be inaccessible after installation shall be completely painted prior to installation.

Paint shall be applied in accordance with the manufacturer's instructions or as directed by the Supervisor.

Only as much material should be mixed as can be used up in one hour. Over-thinning will not be permitted. After the first coat the surfaces will be soaked evenly four or five times and the second coat shall be applied after leaving for at least overnight.

- 7.2 Where shown on Drawings all exterior finishes shall be painted with Weather Shield/weather coat paint in approved colours as per manufacturer's specifications.

The number of coats shall be as shown on the drawings or as directed by the Supervisor.

- 7.3 All wooden doors shall be painted with approved Matt enamel paint as per manufacturer's recommendation and instructions or after approval of the Supervisor.
- 7.4 Plastic emulsion paint, vinyl emulsion paint or matt enamel paint of the approved make and shade shall be applied to surfaces as shown on Drawings as per manufacturer's instructions. The number of coat shall be as indicated on the Drawings or as directed by the Supervisor.
- 7.5 Two coats of hot bitumen paint shall be applied to exposed concrete surfaces in contact with earth. The first coat shall be allowed to dry for about six hours before applying the second coat. During the operation of painting great care should be taken to avoid air bubbles. The manufacturer's instructions and Supervisor's directions shall be complied with.

## 8. JOB CONDITIONS

- 8.1 Observe manufacturer's recommended minimum and maximum temperature but do not apply paint or finish to any surface unless ambient temperature is 10 degree C or above and less than 43 degree C. No painting shall be done above 90% relative humidity.
- 8.2 Place drop cloths to adequately protect all finished work.
- 8.3 Remove and replace all items of finish hardware, device plates, accessories, lighting fixtures or other removable items.
- 8.4 In no case shall any finish hardware or other finished item that is already fitted into place be painted, unless otherwise specified.

## 9. QUALITY ASSURANCE

All paint for any one surface shall be top quality, of one manufacturer and approved by the Supervisor. Deep tone accent colours shall be used and the unavailability of final coat colours may be the basis for rejecting materials for any one surface.

## 10. SCHEDULE OF MEASUREMENT OF PAINT AREA:

- 10.1 Irrespective of prime coats and number of paint coats applied to painting surface area of column, walls, projections, ceilings, false ceilings and other surfaces (Except gates, doors and windows) shall be measured as per actual paint surface area for single time only and paid in accordance with quoted rate of Bill of Quantities.

## 11. MEASUREMENT AND PAYMENT

### 11.1 General

Except otherwise specified herein or elsewhere in Contract Documents, no measurement and payment will be made for the under mentioned specified works related to the relevant items of the Bill of Quantities. The cost thereof shall be deemed to have been included in the quoted unit rate of the respective items of Bill of Quantities.

The rates quoted by the Contractor in the Bill of Quantities shall include work to be executed under these specification in any floor and at any height except where otherwise specifically stated in the relevant item of Bill of Quantities and the Contractor shall not be entitled to any claim or claim any compensation on this account.

- 11.1.1 Preparatory works, including preparatory materials, scraping, scratching, sand blasting, cleaning, prime coating, priming, protection of finished works etc.
  - 11.1.2 Polishing works, including preparatory materials, scraping, cleaning, sanding etc.
  - 11.1.3 Painting work on steel & wooden surfaces.
  - 11.1.4 Before application of paint on existing surface the old paint surface shall be removed existing paint, filling of cracks, surface preparation and application of primer coat, if any.
- 11.2 Painting
- 11.2.1 Measurement

Measurement of acceptably completed respective type of painting works will be made on the basis of net actual areas in square meter of the surface painted as shown on the Drawings or as directed by the Supervisor.
  - 11.2.2 Payment

Payment will be made for acceptable measured quantity of respective type of painting on the basis of unit rate per square meter quoted in the Bill of Quantities and shall constitute full compensation for all the works related to the item.

## **SECTION 6701 - TEXTURED / GRAFFITO WALL COATING**

### **1. SCOPE**

The work under this section of the Specifications consists of furnishing all materials, plant, labour, equipment, appliances and performing all operations in connection with surface preparation, mixing, and application of graffito wall coating as shown on the Drawings and/or as directed by the Supervisor. The scope of this section of specifications is covered with detailed specifications as laid down herein.

### **2. GENERAL**

- 2.1 Except as otherwise specified, all painting shall be applied in conformity with BS CP 231 "Painting of Building" as applicable to the work.
- 2.2 The Supervisor will furnish a schedule of colors for each area and surface. All colors shall be mixed in accordance with the manufacturer's instructions.



- 2.3 Samples of all colors/coating, stains and finishes shall be prepared in advance of requirement so as not to delay work and shall be submitted to the Supervisor for approval before any work is commenced. Any work done without such approval shall be redone to the Supervisor's satisfaction, without additional expense to the Employer. Samples of each type of coating shall be on separate 300 x 300 x 3 mm tempered hard based panels. Manufacturer's colour chart shall be submitted for colour specifications.

### 3. MATERIAL

3.1 Material shall be acceptable, proven, top-grade products and shall meet or exceed the minimum standards of reputable manufacturers as approved by the Supervisor.

3.2 The material for textured graffiti coating shall be variable granular material and shall composed of Acrylic Copolymer Emulsions spheroidal quartz various additives, metallic oxides, inerts of different granulemetries colouring agent, antibacterial and anti-fungus agents.

3.3 All materials shall be delivered to site in their original unbroken containers or packages and bear the manufacturer's name, label, brand and formula and will be mixed and applied in accordance with his directions.

### 4. SURFACE PREPARATION

4.1 All oil, grease, dirt, dust, loose mill scale and any other foreign substance shall be removed from the surface to be coated. Following the solvent cleaning, the surfaces shall be cleaned by scraping, chipping, blasting, wire brushing or other effective means as approved by the Supervisor.

4.2 In the event the surfaces become otherwise contaminated in the Interval between cleaning and costing, recleaning will be done by the Contractor at no additional cost.

No work in this section shall be allowed until all surfaces or conditions have been inspected and approved by the Supervisor.

### 5. APPLICATION

The graffiti coating material should be applied with stainless steel trowel and finished with plastic trowel in thickness as per manufacturer's specification. To get straight texture plastic trowel should be moved vertically and the trowel is to be rotated to obtain swirl texture.

### 6. MEASUREMENT AND PAYMENT

#### 6.1 General

Except otherwise specified herein or elsewhere in Contract Documents, no measurement and payment will be made for the under mentioned specified works related to the relevant items of the Bills of Quantities. The cost thereof shall be deemed to have been included in the quoted unit rate of the respective items of Bills of Quantities.

6.1.1 Preparatory works, including preparatory materials, scraping, scratching, sand paper rubbing, cleaning, protection of finished works etc.

6.1.2 Providing and applying rough plaster base.

6.1.3 Corner, pattas, roundings, arches, borders, grooves etc.

## 6.2 Measurement

Measurement of acceptably completed works of graffiti coating to specified surfaces will be made on the basis of actual area in square meter of the surface coated as shown on the Drawing or as directed by the Supervisor.

## 6.3 Payment

Payment will be made for acceptable measured quantity of coating to specified surfaces on the basis of unit rate per square meter quoted in the Bill of Quantities & shall constitute full compensation for all the works related to the item.

## **SECTION 7200 – BUILDING INSULATION**

### **1.0 Description and General Requirements**

This specification section describes general requirement associated with the supply, manufacture and insulation of materials, equipment and accessories as required or shown on the drawings, for building insulation.

### **2.0 Materials**

#### *2.1 Batt Insulation*

Provide and install 10cm thick fiberglass insulation blankets, lay in rolls on plywood ceiling and between the trusses.

#### *2.2 Vapour Barrier*

Provide 200 micron polyethylene sheet under concrete slab on grade.

#### *2.3 Polystyrene Ceiling/Roof and Floor Insulation*

Expanded Polystyrene (Thermopore) shall have a density of not less than 25 kg/m<sup>3</sup>. See also Section

6411 (Waterproofing and Built-Up Roofing).

## **SECTION 15000 PLUMBING**

### **1.0 Description and Requirement**

## PLUMBING, GENERAL PURPOSE

### 1.2 MATERIAL AUTHENTICATION DATA INCLUDED IN DESIGN ANALYSIS

The following is submitted in accordance with bid documents. It is included in the Design Analysis for this project.

#### SD-03 Product Data

##### Plumbing Fixture Schedule

Catalogue cuts of specified plumbing fixtures system and related piping system and system location where installed.

##### Plumbing System

Diagrams, instructions, and other sheets proposed for posting. Manufacturer's recommendations for the installation.

#### SD-06 Test Reports

##### Tests, Flushing and Disinfection

Test reports in booklet form showing all field tests performed to adjust each component and all field tests performed to prove compliance with the specified performance criteria, completion and testing of the installed system. Each test report shall indicate the final position of controls.

##### Test of Backflow Prevention Assemblies

Certification of proper operation shall be as accomplished in accordance with state regulations by an individual certified by the state to perform such tests. If no state requirement exists, the Contractor shall have the manufacturer's representative test the device, to ensure the unit is properly installed and performing as intended. The Contractor shall provide written documentation of the tests performed and signed by the individual performing the tests.

#### SD-10 Operation and Maintenance Data Plumbing System

Provide copies of the operation manual outlining the step-by-step procedures required for system startup, operation and shutdown. The manual shall include the manufacturer's name, model number, service manual, parts list, and brief description of all equipment and their basic operating features. Provide copies of the maintenance manual listing routine maintenance procedures, possible breakdowns and repairs. The manual shall include piping and equipment layout and simplified wiring and control diagrams of the system as installed.

Operation and Maintenance Manuals shall be as required in Section 01060: SPECIAL CLAUSE entitled OPERATION AND MAINTENANCE (O&M) DATA FOR EQUIPMENT AND SYSTEMS, and include the additional requirements as specified hereinafter. In the event of a conflict, the more detailed requirement shall apply.

### 1.4 STANDARD PRODUCTS

Specified materials and equipment shall be standard products of a manufacturer regularly engaged in the manufacture of such products. Specified equipment shall essentially duplicate equipment that has performed satisfactorily at least two years prior to bid opening.

### 1.6 REGULATORY REQUIREMENTS

Plumbing work shall be in accordance with ICC International Plumbing Code.

## 1.7 PROJECT/SITE CONDITIONS

The Contractor shall become familiar with details of the work, verify dimensions in the field, and advise the Government of any discrepancy before performing any work.

## PART 2 PRODUCTS

### 2.1 MANUFACTURER

Acceptable Manufacturers:

Subject to compliance with requirements, manufacturers offering accessories that may be incorporated into the Work include, but are not limited to, the following:

- PVC & UPVC Pipe - Afghan Milli Plastic or Kawsar Company.
- GI Pipe – iiL Master (Pakistan)

### 2.2 MATERIALS

Materials for various services shall be in accordance with TABLES I and II. Pipe schedules shall be selected based on service requirements. Pipe fittings shall be compatible with the applicable pipe materials. Plastic pipe, fittings, and solvent cement used for potable hot and cold water service shall bear the seal or other identification for potable water use. Material or equipment containing lead shall not be used in any potable water system. In line devices such as water meters, building valves, check valves, meter stops, valves, fittings and back flow preventers shall comply with requirements for safe drinking water. End point devices such as drinking water fountains, lavatory faucets, kitchen faucets, ice makers, supply stops and end point control valves used to dispense water for drinking must meet the requirements for drinking water safely and all applicable health code provisions.

Where locally produced materials that meet requirements are available, use these before imported materials.

Basis of Design PPRC Pipe and Fitting Manufacturers: JAKKO Turkey or International Industries, Limited.

Basis of Design for PVC Drainage Pipes: Nepro, Nibco, or Egeplast.

#### 2.2.1 Pipe Joint Materials

Grooved pipe and hubless cast-iron soil pipe shall not be used underground. Joints and gasket materials shall conform to the following:

- a. Couplings for Grooved Pipe: Ductile Iron, Malleable Iron, or Copper.
- b. Solder Material: Solder metal shall conform to ASTM B 32.
- c. Solder Flux: Flux shall be liquid form, non-corrosive, and conform to ASTM B 813, Standard Test 1.
- d. Flexible Elastomeric Seals: ASTM D 3139, ASTM D 3212 or ASTM F 477.
- e. Bolts and Nuts for Grooved Pipe Couplings: Heat-treated carbon steel.

f. Solvent Cement for Transition Joints between ABS and PVC Nonpressure Piping Components: Per pipe manufacturer's recommendation.

g. Plastic Solvent Cement for PVC Plastic Pipe: Per pipe manufacturer's recommendation.

h. Flanged fittings including flanges, bolts, nuts, bolt patterns, etc., shall be in accordance with ASME B16.5 class 150 and shall have the manufacturer's trademark affixed in accordance with MSS SP-25. Flange material shall conform to ASTM A 105/A 105M. Blind flange material shall conform to ASTM A 516/A 516M cold service and ASTM A 515/A 515M for hot service. Bolts shall be high strength or intermediate strength with material conforming to ASTM A 193/A 193M.

### 2.2.2 Miscellaneous Materials

Miscellaneous materials shall conform to the following:

a. Hose Clamps: SAE J1508.

b. Supports for Off-the-Floor Plumbing Fixtures: ASME A112.6.1M.

c. Hypochlorite: AWWA B300.

d. Liquid Chlorine: AWWA B301.

e. Gauges -Pressure and Vacuum Indicating Dial Type - Elastic Element: ASME B40.1.

f. Water Hammer Arrester: Engineered metal-bellows or piston type with pressurized metal cushioning chamber. Sizes shall be based on water flow and pressure, arrester locations and spacing, quantity and type of fixtures served, and pipe size, in accordance with applicable Intl Plumbing Code requirements and ASTM standards or as recommended by water hammer arrester manufacturer.

### 2.2.3 Pipe Insulation Material

Insulation shall be as specified in Section 15080 THERMAL INSULATION FOR MECHANICAL SYSTEMS.

## 2.3 PIPE HANGERS, INSERTS, AND SUPPORTS

Pipe hangers, inserts, and supports shall conform to MSS SP-58 and MSS SP-69. Basis of Design: Baykan Kelepçe, Pipe Clamps with Standard Bolt; Link Ltd, MATS-Adjustable Pipe Saddle Support; or Vibration Management Corporation (VIMCO), SCH Standard Clevis Hanger.

## 2.4 VALVES

Valves shall be provided on supplies to equipment and fixtures. Valves 65 mm (2 1/2 inches) and smaller shall be bronze or brass with threaded bodies for pipe. Valves 80 mm (3 inches) and larger shall have flanged iron bodies and bronze trim. Pressure ratings shall be based upon the application. Valves shall conform to the following standards:

Basis of Design: E.C.A., Elginkan Group, or Wilkins Operation (A Zurn company).

### **Description**

### **Standard**

Backwater Valves	ASME A112.14.1
Vacuum Relief Valves	ANSI Z21.22
Basis of Design: Watts Regulator, Watts Industries, Inc.;	Model N36-M1.
Water Pressure Reducing Valves	ASSE 1003
Water Heater Drain Valves	ASSE 1005
Trap Seal Primer Valves	ASSE 1018

Temperature and Pressure Relief Valves for Hot Water Supply Systems ANSI Z21.22

#### 2.4.1 Wall Faucets/Spigots

Wall faucets with vacuum-breaker backflow preventer shall be brass with 20 mm (3/4 inch) male inlet threads, hexagon shoulder, and 20 mm (3/4 inch) hose connection. Faucet handle shall be securely attached to stem.

##### 2.4.1.1 Room Hose Bibbs and Floor Drains

Room hose bibs and floor drains shall be provided as required. Afghan dining facility kitchen area clean-up hose bib to be supplied with connecting hose on reel including approximately 12 meters of hose. Provide clean-up spray nozzle with hose assembly.

#### 2.4.2 Gate Valves

Gate valves shall be designed for a working pressure of not less than 1.03 MPa (150 psi). Valve connections shall be as required for the piping in which they are installed. Valves shall have a clear waterway equal to the full nominal diameter of the valve, and shall be opened by turning counterclockwise.

- a. Valves smaller than 80 mm (3 inches) shall be bronze or brass and shall conform to MSS SP-80, Type 1, Class 150, DIN 3352, BS 21, or ASME B1.20.1.
- b. Valves 80 mm (3 inches) and larger shall be iron body, bronze mounted, and shall conform to AWWA C500, DIN 3352, or BS 5163. Flanges shall not be buried. An approved pit shall be provided for all flanged connections.
- c. Resilient-Seated Gate Valves: For valves 80 to 300 mm (3 to 12 inches) in size, resilient-seated gate valves shall conform to AWWA C509, DIN 3352 or BS 5163.

#### 2.5 Relief Valves

Water heaters and hot water storage tanks shall have a combination pressure and temperature (P&T) relief valve. The pressure relief element of a P&T relief valve shall have adequate capacity to prevent excessive pressure buildup in the system when the system is operating at the maximum rate of heat input. The temperature element of a P&T relief valve shall have a relieving capacity which is at least equal to the total input of the heaters when operating at their maximum capacity. Relief valves shall be rated according to ANSI Z21.22. Relief valves for systems where the maximum rate of heat input is less than 59 kW (200,000 Btuh) shall have 20 mm (3/4 inch) minimum inlets, and 20 mm (3/4 inch) outlets. Relief valves for systems where the maximum rate of heat input is greater than 59 kW (200,000 Btuh)

shall have 25 mm (1 inch) minimum inlets, and 25 mm (1 inch) outlets. The discharge pipe from the relief valve shall be the size of the valve outlet.

## 2.6 Pressure Reducing Valve (PRV)

A. Designed to automatically reduce a higher inlet pressure to maintain a set lower downstream pressure regardless of changing flow rate and varying inlet pressure. Main valve to close drip tight when downstream pressure exceeds set pressure.

2.7 Thermostatic Mixing Valves Mixing valves, thermostatic type, pressure-balanced or combination thermostatic and pressure-balanced shall be line size and shall be constructed with rough or finish bodies either with or without plating. Each valve shall be constructed to control the mixing of hot and cold water and to deliver water at a desired temperature regardless of pressure or input temperature changes. The control element shall be of an approved type. The body shall be of heavy cast bronze, and interior parts shall be brass, bronze, corrosion-resisting steel or copper. The valve shall be equipped with necessary stops, check valves, unions, and sediment strainers on the inlets. Mixing valves shall maintain water temperature within 2 degrees C of any setting.

## 2.8 FIXTURES

All plumbing fixtures shall be provided with p-traps and shall be vented to the roof per International Plumbing Code, latest edition. Fixtures provided inside the prison cells shall be institutional type and tamper-proof.

### 2.8.1 Western Style Water Closet with Flush Tank

Provide acid resisting fired porcelain enameled cast iron water closet complete with rotating No-Hub 'P' trap and No-Hub coupling to meet piping requirements. Eastern Style water closet shall be furnished with integral non-skid foot pads and bowl wash down non-splashing flushing rim. The water closet shall be completely self-supporting requiring no external mounting hardware and shall be flush with floor. The Eastern Style water closet shall incorporate waterproofing membrane flashing flange. Provide wall mounted hose next to the water closet stall. Toilets shall be oriented North and South. Toilets shall not face East or West. Contractor shall verify all eastern toilets are facing North and South and adjust building orientation or rotate toilets as necessary for each site.

### 2.8.2 Western Water Closet

Western water closet with flush tank assembly as specified by the designer. Vitreous china color mounted, elongated bowl type. Provide at least one (1) western type water closet in HQ Buildings.

### 2.8.3 Lavatories

All sinks shall be trough type constructed of block and concrete with ceramic tile exterior and lining capable of withstanding abuse. Faucets shall be chrome plated brass single lever mixing type. Provide maintenance access to waste piping and P-traps from under the sink. Lavatories inside the prison cells shall be temper-proof with integral spout, soap depression, and outlet connection to slip 40 mm OD tubing. Install 300 mm length water hammer arresters for all water supply piping for lavatories.

### 2.8.4 Shower

Shower heads, other than emergency showers, shall be nonadjustable spray type.

Wall Mounted: Shower head shall be nonadjustable spray, stainless steel or chromium plated brass with ball joint. Handles shall be manufacturer's option. Control valves shall be copper alloy, nickel alloy,

or stainless steel. Valves shall be mechanical mixing, with separate hot and cold water. Shower head shall be vandalproof with integral back. Each shower compartment shall be additionally furnished with a flexible 1.5 m spray hose, with hanger, attached to a hose faucet mounted below the control valve. The shower head and the spray hose shall each have a valve so flow can be diverted to either outlet.

## 2.9 BACKFLOW PREVENTERS

Backflow preventers shall be approved and listed by the Foundation For Cross-Connection Control & Hydraulic Research. Reduced pressure principle assemblies, double check valve assemblies, atmospheric (nonpressure) type vacuum breakers, and pressure type vacuum breakers shall be tested, approved, and listed in accordance with FCCCHR-CCC Manual-9, Section 10. Backflow preventers with intermediate atmospheric vent shall conform to ASSE 1012. Reduced pressure principle backflow preventers shall conform to ASSE 1013. Hose connection vacuum breakers shall conform to ASSE 1011. Pipe applied atmospheric type vacuum breakers shall conform to ASSE 1001. Pressure vacuum breaker assembly shall conform to ASSE 1020. Air gaps in plumbing systems shall conform to ASME A112.1.2.

Basis of Design: Wilkins; Model 975LXL. Brandoni; Model ECO 3T; Conbraco; or Wilkins Operation (A Zurn company).

## 2.10 DRAINS

### 2.10.1 Floor or Shower Drains (FD-A)

Floor drains shall consist of a galvanized body, integral seepage pan, and adjustable perforated or slotted chromium-plated bronze, nickel-bronze, or nickel-brass strainer, consisting of grate and threaded collar. Floor drains shall be cast iron except where metallic waterproofing membrane is installed. Drains shall be of double drainage pattern for embedding in the floor construction. The seepage pan shall have weep holes or channels for drainage to the drainpipe. The strainer shall be adjustable to floor thickness. A clamping device for attaching flashing or waterproofing membrane to the seepage pan without damaging the flashing or waterproofing membrane shall be provided when required. Drains shall be provided with threaded connection. Between the drain outlet and waste pipe, a neoprene rubber gasket may be installed, provided that the drain is specifically designed for the rubber gasket compression type joint. Floor and shower drains shall conform to ASME A112.21.1M.

Basis of Design: Zurn ZN415 body assembly with "Type B" strainer floor drain.

#### 2.10.1.1 Drains

Drains and backwater valves installed in connection with waterproofed floors or shower pans shall be equipped with bolted-type device to securely clamp flashing.

## 2.11 WATER HEATERS

Water heater types and capacities shall be as indicated on Drawings. Each water heater shall have replaceable anodes. Each primary water heater shall have controls with an adjustable range that includes 32 to 71 degrees C (90 to 160 degrees F). Each gas-fired water heater and booster water heater shall have controls with an adjustable range that includes 49 to 82 degrees C (120 to 180 degrees F). Hot water systems utilizing recirculation systems shall be tied into building off-hour controls. The only exception is that storage water heaters and hot water storage tanks having more than 2000 liters storage capacity need not meet the standard loss requirement if the tank surface area is insulated to R-12.5 and if a standing light is not used. Plastic materials polyetherimide (PEI) and polyethersulfone (PES) are forbidden to be used for vent piping of combustion gases.



For 100 liter (25 gallon) water heater with vacuum relief valve, pressure/temperature relief valve, and drain valve, use Konifer Series 100lt hot water heater by Baymak A.S, or Jumbo series by Zenith.

2.16.1 Automatic Storage Type Heaters shall be complete with control system, temperature gauge, and pressure gauge, and shall have combination pressure and temperature relief valve. An enamel coating shall be provided.

#### 2.11.1.1 Electric Type

Electric water heaters types and capacities shall be as indicated on Drawings. Electric water heaters shall be of the cylindrical, pressure type, comprised of inner tank, insulation, outer jacket, immersion type electric heating elements, thermostat, control box, pressure relief valve, water connections and either floor mounting legs or wall brackets suitable for the type and size of heater used. Inner tank shall be constructed of heavy gauge welded steel with a corrosion-resistant lining, designed for a working pressure of minimum 6 bar. Outer jacket shall be of enamel or epoxy polyester painted heavy gauge steel. Space between the tank and outer jacket shall be filled with insulation of adequate thickness for minimum heat loss. Each water heater shall have replaceable magnesium anodes to protect the heater against corrosion. Each water heater shall have temperature controls with an adjustable range that includes 32 to 71 degrees C. Electric type water heaters shall be equipped with heating elements in quantities required to meet required operating parameters. Each element shall be 4.5 KW or as indicated on Drawings. The elements shall be wired for simultaneous operation of multiple elements at any given time, unless otherwise noted. An enamel coating shall be provided.

### PART 3 EXECUTION

#### 3.1 GENERAL INSTALLATION REQUIREMENTS

The plumbing system shall be installed complete with necessary fixtures, fittings, traps, valves, and accessories. Water and drainage piping shall be extended 1.5 m outside the building, unless otherwise indicated. A gate valve or ball valve and drain shall be installed on the water service line inside the building approximately 150 mm above the floor from point of entry. Piping shall be connected to the exterior service lines or capped or plugged if the exterior service is not in place. Sewer and water pipes shall be laid in separate trenches, except when otherwise shown. Exterior underground utilities shall be at least 300 mm below the finish grade or as indicated on the drawings. If trenches are closed or the pipes are otherwise covered before being connected to the service lines, the location of the end of each plumbing utility shall be marked with a stake or other acceptable means. Valves shall be installed with control no lower than the valve body.

##### 3.1.1 Water Pipe, Fittings, and Connections

###### 3.1.1.1 Utilities

The piping shall be extended to outlets, and equipment. The cold-water piping system shall be arranged and installed to permit draining. The supply line to each item of equipment shall be equipped with a shutoff valve to enable isolation of the item for repair and maintenance without interfering with operation of other equipment. Supply piping to devices shall be anchored to prevent movement.

###### 3.1.1.2 Cutting and Repairing

The work shall be carefully laid out in advance, and unnecessary cutting of construction shall be avoided. Damage to building, piping, wiring, or equipment as a result of cutting shall be repaired by mechanics skilled in the trade involved.

###### 3.1.1.3 Protection of Fixtures, Materials, and Equipment

Pipe openings shall be closed with caps or plugs during installation. Fixtures and equipment shall be tightly covered and protected against dirt, water, chemicals, and mechanical injury. Upon completion of the work, the fixtures, materials, and equipment shall be thoroughly cleaned, adjusted, and operated. Safety guards shall be provided for exposed rotating equipment.

#### 3.1.1.4 Mains, Branches, and Run outs

Piping shall be installed as indicated. Pipe shall be accurately cut and worked into place without springing or forcing. Structural portions of the building shall not be weakened. Aboveground piping shall run parallel with the lines of the building, unless otherwise indicated. Branch pipes from service lines may be taken from top, bottom, or side of main, using crossover fittings required by structural or installation conditions. Supply pipes, valves, and fittings shall be kept a sufficient distance from other work and other services to permit not less than 12 mm between finished covering on the different services. Bare and insulated water lines shall not bear directly against building structural elements so as to transmit sound to the structure or to prevent flexible movement of the lines. Water pipe shall not be buried in or under floors unless specifically indicated or approved. Changes in pipe sizes shall be made with reducing fittings. Use of bushings will not be permitted except for use in situations in which standard factory fabricated components are furnished to accommodate specific accepted installation practice. Change in direction shall be made with fittings, except that bending of pipe 100 mm (4 inches) and smaller will be permitted, provided a pipe bender is used and wide sweep bends are formed. The center-line radius of bends shall be not less than six diameters of the pipe. Bent pipe showing kinks, wrinkles, flattening, or other malformations will not be acceptable.

#### 3.1.1.5 Pipe Drains

Pipe drains indicated shall consist of 20 mm (3/4 inch) hose bibb with renewable seat and gate or ball valve ahead of hose bibb. At other low points, 20 mm (3/4 inch) brass plugs or caps shall be provided. Disconnection of the supply piping at the fixture is an acceptable drain.

#### 3.1.1.6 Expansion and Contraction of Piping

Allowance shall be made throughout for expansion and contraction of water pipe. Each hot-water and hot-water circulation riser shall have expansion loops or other provisions such as offsets, changes in direction, etc., where indicated and/or required. Risers shall be securely anchored as required or where indicated to force expansion to loops. Branch connections from risers shall be made with ample swing or offset to avoid undue strain on fittings or short pipe lengths. Horizontal runs of pipe over 15 m in length shall be anchored to the wall or the supporting construction about midway on the run to force expansion, evenly divided, toward the ends. Sufficient flexibility shall be provided on branch runouts from mains and risers to provide for expansion and contraction of piping. Flexibility shall be provided by installing one or more turns in the line so that piping will spring enough to allow for expansion without straining.

#### 3.1.1.7 Thrust Restraint

Plugs, caps, tees, valves and bends deflecting 11.25 degrees or more, either vertically or horizontally, in waterlines 100 mm in diameter or larger shall be provided with thrust blocks, where indicated, to prevent movement. Thrust blocking shall be concrete of a mix not leaner than: 1 cement, 2-1/2 sand, 5 gravel; and having a compressive strength of not less than 14 MPa after 28 days. Blocking shall be placed between solid ground and the fitting to be anchored. Unless otherwise indicated or directed, the base and thrust bearing sides of the thrust block shall be poured against undisturbed earth. The side of the thrust block not subject to thrust shall be poured against forms. The area of bearing will be as shown. Blocking shall be placed so that the joints of the fitting are accessible for repair. Steel rods and clamps,

protected by galvanizing or by coating with bituminous paint, shall be used to anchor vertical down bends into gravity thrust blocks.

### 3.1.5 Pipe Sleeves and Flashing

Pipe sleeves shall be furnished and set in their proper and permanent location.

#### 3.1.5.1 Sleeve Requirements

Pipes passing through concrete or masonry walls or concrete floors or roofs shall be provided with pipe sleeves fitted into place at the time of construction. Sleeves are not required for supply, drainage, waste and vent pipe passing through concrete slab on grade, except where penetrating a membrane waterproof floor. A modular mechanical type sealing assembly may be installed in lieu of a waterproofing clamping flange and caulking and sealing of annular space between pipe and sleeve. The seals shall consist of interlocking synthetic rubber links shaped to continuously fill the annular space between the pipe and sleeve using galvanized steel bolts, nuts, and pressure plates. The links shall be loosely assembled with bolts to form a continuous rubber belt around the pipe with a pressure plate under each bolt head and each nut. After the seal assembly is properly positioned in the sleeve, tightening of the bolt shall cause the rubber sealing elements to expand and provide a watertight seal between the pipe and the sleeve. Each seal assembly shall be sized as recommended by the manufacturer to fit the pipe and sleeve involved. Sleeves shall not be installed in structural members, except where indicated or approved. Rectangular and square openings shall be as detailed. Each sleeve shall extend through its respective floor, or roof, and shall be cut flush with each surface, except for special circumstances. Pipe sleeves passing through floors in wet areas such as mechanical equipment rooms, lavatories, kitchens, and other plumbing fixture areas shall extend a minimum of 100 mm above the finished floor. Unless otherwise indicated, sleeves shall be of a size to provide a minimum of 6 mm (1/4 inch) clearance between bare pipe or insulation and inside of sleeve or between insulation and inside of sleeve. Sleeves in bearing walls and concrete slab on grade floors shall be steel pipe or cast-iron pipe. Sleeves in nonbearing walls or ceilings may be steel pipe, cast-iron pipe, galvanized sheet metal with lock-type longitudinal seam, or plastic. Except as otherwise specified, the annular space between pipe and sleeve, or between jacket over insulation and sleeve, shall be sealed as indicated with sealants conforming to ASTM C 920 and with a primer, backstop material and surface preparation as specified in Section 07900 JOINT SEALING. The annular space between pipe and sleeve, between bare insulation and sleeve or between jacket over insulation and sleeve shall not be sealed for interior walls which are not designated as fire rated. Sleeves through below-grade walls in contact with earth shall be recessed 12 mm (1/2 inch) from wall surfaces on both sides. Annular space between pipe and sleeve shall be filled with backing material and sealants in the joint between the pipe and masonry wall as specified above. Sealant selected for the earth side of the wall shall be compatible with dampproofing/waterproofing materials that are to be applied over the joint sealant.

#### 3.1.5.2 Flashing Requirements

Pipes passing through roof shall be installed through a 4.9 kg per square meter (16 ounce) copper flashing, each within an integral skirt or flange. Flashing shall be suitably formed, and the skirt or flange shall extend not less than 200 mm from the pipe and shall be set over the roof or floor membrane in a solid coating of bituminous cement. The flashing shall extend up the pipe a minimum of 250 mm. For cleanouts, the flashing shall be turned down into the hub and caulked after placing the ferrule. Pipes passing through pitched roofs shall be flashed, using lead or copper flashing, with an adjustable integral flange of adequate size to extend not less than 200 mm from the pipe in all directions and lapped into the roofing to provide a watertight seal. The annular space between the flashing and the bare pipe or between the flashing and the metal-jacket-covered insulation shall be sealed as indicated. Flashing for dry vents shall be turned down into the pipe to form a waterproof joint. Pipes, up to and including 250 mm (10 inches) in diameter, passing through roof or floor waterproofing membrane may be installed through a cast-iron sleeve with caulking recess, anchor lugs, flashing-clamp device, and pressure ring

with brass bolts. Flashing shield shall be fitted into the sleeve clamping device. Pipes passing through wall waterproofing membrane shall be sleeved as described above. A waterproofing clamping flange shall be installed.

### 3.1.5.3 Waterproofing

Waterproofing at floor-mounted water closets shall be accomplished by forming a flashing guard from soft-tempered sheet copper. The center of the sheet shall be perforated and turned down approximately 40 mm to fit between the outside diameter of the drainpipe and the inside diameter of the cast-iron or steel pipe sleeve. The turned-down portion of the flashing guard shall be embedded in sealant to a depth of approximately 40 mm; then the sealant shall be finished off flush to floor level between the flashing guard and drainpipe. The flashing guard of sheet copper shall extend not less than 200 mm from the drainpipe and shall be lapped between the floor membrane in a solid coating of bituminous cement.

### 3.1.5.5 Pipe Penetrations of Slab on Grade Floors

Where pipes, fixture drains, floor drains, cleanouts or similar items penetrate slab on grade floors, except at penetrations of floors with waterproofing membrane as specified in paragraphs Flashing Requirements and Waterproofing, a groove 6 to 13 mm wide by 6 to 10 mm deep shall be formed around the pipe, fitting or drain. The groove shall be filled with a sealant as specified in Section 07900 JOINT SEALING.

## 3.1.6 Supports

### 3.1.6.1 General

Hangers used to support piping 50 mm (2 inches) and larger shall be fabricated to permit adequate adjustment after erection while still supporting the load. Pipe guides and anchors shall be installed to keep pipes in accurate alignment, to direct the expansion movement, and to prevent buckling, swaying, and undue strain. Piping subjected to vertical movement when operating temperatures exceed ambient temperatures shall be supported by variable spring hangers and supports or by constant support hangers. In the support of multiple pipe runs on a common base member, a clip or clamp shall be used where each pipe crosses the base support member. Spacing of the base support members shall not exceed the hanger and support spacing required for an individual pipe in the multiple pipe run. Threaded sections of rods shall not be formed or bent.

### 3.1.6.2 Pipe Supports and Structural Bracing, Seismic Requirements

Piping and attached valves shall be supported and braced to resist seismic loads as specified in Section 15070 SEISMIC PROTECTION FOR MECHANICAL EQUIPMENT. Structural steel required for reinforcement to properly support piping, headers, and equipment, but not shown, shall be provided.

### 3.1.6.3 Pipe Hangers, Inserts, and Supports

Installation of pipe hangers, inserts and supports shall conform to MSS SP-58 and MSS SP-69, except as modified herein.

- a. Inserts shall be secured to concrete forms before concrete is placed. Continuous inserts which allow more adjustment may be used.

b. C-clamps shall be torqued per MSS SP-69 and shall have both locknuts and retaining devices furnished by the manufacturer. Field-fabricated C-clamp bodies or retaining devices are not acceptable.

c. Attachments used on angles and channels shall be furnished with an added malleable-iron heel plate or adapter.

d. Saddles shall be used on insulated pipe 100 mm (4 inches) and larger when the temperature of the medium is 15 degrees C or higher. Saddles shall be welded to the pipe.

e. Shields shall:

(1) Be used on insulated pipe less than 100 mm (4 inches).

(2) Be used on insulated pipe 100 mm (4 inches) and larger when the temperature of the medium is 15 degrees C or less.

(3) Have a high density insert for all pipe sizes. High density inserts shall have a density of 128 kg per cubic meter (8 pcf) or greater.

f. Horizontal pipe supports shall be spaced as specified in MSS SP-69 and a support shall be installed not over 300 mm from the pipe fitting joint at each change in direction of the piping. Pipe supports shall be spaced not over 1.5 m apart at valves. Operating temperatures in determining hanger spacing for PVC pipe shall be 49 degrees C. Horizontal pipe runs shall include allowances for expansion and contraction.

g. Vertical pipe shall be supported at each floor, except at slab-on-grade, at intervals of not more than 4.5 m not more than 2m from end of risers, and at vent terminations. Vertical pipe risers shall include allowances for expansion and contraction.

h. Guides using steel, reinforced polytetrafluoroethylene (PTFE) or graphite slides shall be provided to allow longitudinal pipe movement. Slide materials shall be suitable for the system operating temperatures, atmospheric conditions, and bearing loads encountered. Lateral restraints shall be provided as needed. Where steel slides do not require provisions for lateral restraint the following may be used:

(1) On pipe 100 mm (4 inches) and larger when the temperature of the medium is 15 degrees C or higher, a saddle, welded to the pipe, may freely rest on a steel plate.

(2) On pipe less than 100 mm (4 inches) a shield, attached to the pipe or insulation, may freely rest on a steel plate.

(3) On pipe 100 mm (4 inches) and larger carrying medium less than 15 degrees C a shield, attached to the pipe or insulation, may freely rest on a steel plate.

i. Pipe hangers on horizontal insulated pipe shall be the size of the outside diameter of the insulation. The insulation shall be continuous through the hanger on all pipe sizes and applications.

j. Where there are high system temperatures and welding to piping is not desirable, the guide shall include a pipe cradle, welded to the guide structure and strapped securely to the pipe. The pipe shall be separated from the slide material by at least 100 mm or by an amount adequate for the insulation, whichever is greater.

k. Hangers and supports for plastic pipe shall not compress, distort, cut or abrade the piping, and shall allow free movement of pipe except where otherwise required in the control of expansion/contraction.

### 3.1.7 Pipe Cleanouts

Pipe cleanouts shall be the same size as the pipe except that cleanout plugs larger than 100 mm (4 inches) will not be required. Cleanouts in connection with pipe, where indicated, shall be T-pattern, 90-degree branch drainage fittings with plastic plugs. Plugs shall be the same size as the pipe up to and including 100 mm (4 inches). Cleanout tee branches with screw plug shall be installed at the foot of soil and waste stacks, at the foot of interior downspouts, on each connection to building storm drain where interior downspouts are indicated, and on each building drain outside the building. Cleanout tee branches may be omitted on stacks in single story buildings with slab-on-grade construction or where less than 450 mm of crawl space is provided under the floor. Cleanouts on pipe concealed in partitions shall be provided with chromium plated bronze, nickel bronze, nickel brass or stainless steel flush type access cover plates. Round access covers shall be provided and secured to plugs with securing screw. Square access covers may be provided with matching frames, anchoring lugs and cover screws. Cleanouts in finished walls shall have access covers and frames installed flush with the finished wall. Cleanouts installed in finished floors subject to foot traffic shall be provided with a chrome-plated cast brass, nickel brass, or nickel bronze cover secured to the plug or cover frame and set flush with the finished floor. Heads of fastening screws shall not project above the cover surface. Where cleanouts are provided with adjustable heads, the heads shall be plastic.  
Basis of Design: Mast; Model CO-50; Smith 4051 series; Zurn.

## 3.2 FIXTURE TRIMMINGS

### 3.2.1 Access Panels

Access panels shall be provided for concealed valves and controls, or any item requiring inspection or maintenance. Access panels shall be of sufficient size and located so that the concealed items may be serviced, maintained, or replaced.

### 3.2.2 Sight Drains

Sight drains shall be installed so that the indirect waste will terminate 50 mm above the flood rim of the funnel to provide an acceptable air gap.

### 3.2.3 Traps

Each trap shall be placed as near the fixture as possible, and no fixture shall be double-trapped. Traps installed on steel pipe shall be recess-drainage pattern, or brass-tube type. Traps installed on plastic pipe may be plastic.

## 3.4 PAINTING

Painting of pipes, hangers, supports, and other iron work, either in concealed spaces or exposed spaces, is specified in Section 09900 PAINTS AND COATINGS.

## 3.6 TESTS, FLUSHING AND DISINFECTION

### 3.6.1 Plumbing System

The following tests shall be performed on the plumbing system in accordance with ICC International Plumbing Code.

#### 3.6.1.1 Test of Backflow Prevention Assemblies

Backflow prevention assembly shall be tested using gauges specifically designed for the testing of backflow prevention assemblies. Gauges shall be tested annually for accuracy in accordance with ICC International Plumbing Code requirements and ASTM standards. Report form for each assembly shall include, as a minimum, the following:

Data on Device	Data on Testing Firm
Type of Assembly	Name
Manufacturer	Address
Model Number	Certified Tester
Serial Number	Certified Tester No.
Size Date of Test	Location
Test Pressure Readings	Serial Number and Test Data of Gauges

If the unit fails to meet specified requirements, the unit shall be repaired and retested.

#### 3.6.2 Defective Work

If inspection or test shows defects, such defective work or material shall be replaced or repaired as necessary and inspection and tests shall be repeated. Repairs to piping shall be made with new materials. Caulking of screwed joints or holes will not be acceptable.

#### 3.6.3 Operational Test

Upon completion of flushing and prior to disinfection procedures, the Contractor shall subject the plumbing system to operating tests to demonstrate satisfactory functional and operational efficiency. Such operating tests shall cover a period of not less than 8 hours for each system and shall include the following information in a report with conclusion as to the adequacy of the system:

- a. Time, date, and duration of test.
- b. Water pressures at the most remote and the highest fixtures.
- c. Operation of each floor drain by flooding with water.
- d. Compressed air readings at each compressor and at each outlet. Each indicating instrument shall be read at 1/2 hour intervals. The report of the test shall be submitted in quadruplicate. The Contractor shall furnish instruments, equipment, and personnel required for the tests; the Government will furnish the necessary water and electricity.

### 3.7 WATER HEATERS AND HOT WATER STORAGE TANKS

Electric water heater shall have capacity as indicated on Drawings, safety relief valve, thermal sensing element, magnesium anode and will be enamel coated.

#### 3.7.1 Relief Valves

No valves shall be installed between a relief valve and its water heater or storage tank. The P&T relief valve shall be installed where the valve actuator comes in contact with the hottest water in the heater.

Whenever possible, the relief valve shall be installed directly in a tapping in the tank or heater; otherwise, the P&T valve shall be installed in the hot-water outlet piping. A vacuum relief valve shall be provided on the cold water supply line to the hot-water storage tank or water heater and mounted above and within 150 mm above the top of the tank or water heater.

### 3.7.2 Heat Traps

Piping to and from each water heater and hot water storage tank shall be routed horizontally and downward a minimum of 600 mm before turning in an upward direction.

### 3.7.3 Connections to Water Heaters

Connections of metallic pipe to water heaters shall be made with dielectric unions or flanges.

## 3.8 FIXTURES AND FIXTURE TRIMMINGS

Polished chromium-plated pipe, valves, and fittings shall be provided where exposed to view. Angle stops, straight stops, stops integral with the faucets, or concealed type of lock-shield, and loose-key pattern stops for supplies with threaded, sweat or solvent weld inlets shall be furnished and installed with fixtures. Where connections between copper tubing and faucets are made by rubber compression fittings, a beading tool shall be used to mechanically deform the tubing above the compression fitting. Exposed traps and supply pipes for fixtures and equipment shall be connected to the rough piping systems at the wall, unless otherwise specified under the item. Floor and wall escutcheons shall be as specified. Drain lines and hot water lines of fixtures for handicapped personnel shall be insulated and do not require polished chrome finish. Plumbing fixtures and accessories shall be installed within the space shown.

### 3.8.1 Fixture Connections

Where space limitations prohibit standard fittings in conjunction with the cast iron floor flange, special short-radius fittings shall be provided. Connections between earthenware fixtures and flanges on soil pipe shall be made gastight and watertight with a closet-setting compound or neoprene gasket and seal. Use of natural rubber gaskets or putty will not be permitted. Fixtures with outlet flanges shall be set the proper distance from floor or wall to make a first-class joint with the closet-setting compound or gasket and fixture used.

### 3.8.2 Height of Fixture Rims Above Floor

Lavatories shall be mounted with rim 775 mm above finished floor. Wall-hung drinking fountains and water coolers shall be installed with rim 1020 mm above floor. Wall-hung service sinks shall be mounted with rim 700 mm above the floor.

### 3.8.3 Fixture Supports

Fixture supports for off-the-floor lavatories, urinals, and other fixtures of similar size, design, and use, shall be of the chair-carrier type. The carrier shall provide the necessary means of mounting the fixture, with a foot or feet to anchor the assembly to the floor slab. Adjustability shall be provided to locate the fixture at the desired height and in proper relation to the wall. Support plates, in lieu of chair carrier, shall be fastened to the wall structure only where it is not possible to anchor a floor-mounted chair carrier to the floor slab.

## 3.10 TESTS, FLUSHING AND DISINFECTION

### 3.12.1 Plumbing System



The following tests shall be performed on the plumbing system in accordance with ICC Intl Plumbing Code.

### 3.12.2 Defective Work

If inspection or test shows defects, such defective work or material shall be replaced or repaired as necessary and inspection and tests shall be repeated. Repairs to piping shall be made with new materials. Caulking of screwed joints or holes will not be acceptable.

### 3.12.3 System Flushing

#### 3.12.3.1 During Flushing

Before operational tests or disinfection, potable water piping system shall be flushed with potable water. Sufficient water shall be used to produce a water velocity that is capable of entraining and removing debris in all portions of the piping system. This requires simultaneous operation of all fixtures on a common branch or main in order to produce a flushing velocity of approximately 1.2 meters per second (4 fps) through all portions of the piping system. In the event that this is impossible due to size of system, the Government (or the designated representative) shall specify the number of fixtures to be operated during flushing. Contractor shall provide adequate personnel to monitor the flushing operation and to ensure that drain lines are unobstructed in order to prevent flooding of the facility. Contractor shall be responsible for any flood damage resulting from flushing of the system. Flushing shall be continued until entrained dirt and other foreign materials have been removed and until discharge water shows no discoloration. All faucets and drinking water fountains, to include any device considered as an end point device shall be flushed a minimum of 1 L per 24 hour period, ten times over a 14 day period.

#### 3.12.3.2 After Flushing

System shall be drained at low points. Strainer screens shall be removed, cleaned, and replaced. After flushing and cleaning, systems shall be prepared for testing by immediately filling water piping with clean, fresh potable water. Any stoppage, discoloration, or other damage to the finish, furnishings, or parts of the building due to the Contractor's failure to properly clean the piping system shall be repaired by the Contractor. When the system flushing is complete, the hot-water system shall be adjusted for uniform circulation. Flushing devices and automatic control systems shall be adjusted for proper operation. The water supply to the building shall be tested separately to ensure that any lead contamination found during potable water system testing is due to work being performed inside the building.

### 3.12.4 Operational Test

Upon completion of flushing and prior to disinfection procedures, the Contractor shall subject the plumbing system to operating tests to demonstrate satisfactory functional and operational efficiency. Such operating tests shall cover a period of not less than 8 hours for each system and shall include the following information in a report with conclusion as to the adequacy of the system:

- a. Time, date, and duration of test.
- b. Water pressures at the most remote and the highest fixtures.
- c. Operation of each fixture and fixture trim.
- d. Operation of each valve, hydrant, and faucet.

- e. Temperature of each domestic hot-water supply.
- f. Operation of each floor and roof drain by flooding with water.
- g. Operation of each vacuum breaker and backflow preventer.
- h. Complete operation of each water pressure booster system, including pump start pressure and stop pressure.
- i. Compressed air readings at each compressor and at each outlet. Each indicating instrument shall be read at 1/2 hour intervals. The report of the test shall be submitted in quadruplicate. The Contractor shall furnish instruments, equipment, and personnel required for the tests; the Government will furnish the necessary water and electricity.

### 3.12.5 Disinfection

After operational tests are complete, the entire domestic hot- and cold-water distribution system shall be disinfected. System shall be flushed as specified, before introducing chlorinating material. The chlorinating material shall be hypochlorite or liquid chlorine. Water chlorination procedure shall be in accordance with AWWA M20. The chlorinating material shall be fed into the water piping system at a constant rate at a concentration of at least 50 parts per million (PPM). A properly adjusted hypochlorite solution injected into the main with a hypo chlorinator, or liquid chlorine injected into the main through a solution-feed chlorinator, shall be used. The chlorine residual shall be checked at intervals to ensure that the proper level is maintained. Chlorine application shall continue until the entire main is filled. The water shall remain in the system for a minimum of 24 hours. Each valve in the system being disinfected shall be opened and closed several times during the contact period to ensure its proper disinfection. Following the 24-hour period, no less than 25 PPM chlorine residual shall remain in the system. Water tanks shall be disinfected by the addition of chlorine directly to the filling water. Following a 6 hour period, no less than 50 PPM chlorine residual shall remain in the tank. If after the 24 hour and 6 hour holding periods, the residual solution contains less than 25 PPM and 50 PPM chlorine respectively, flush the piping and tank with potable water, and repeat the above procedures until the required residual chlorine levels are satisfied. The system including the tanks shall then be flushed with clean water until the residual chlorine level is reduced to less than one part per million. During the flushing period each valve and faucet shall be opened and closed several times. Samples of water in disinfected containers shall be obtained from several locations selected by the Government. The samples of water shall be tested for total coli form organisms (coliform bacteria, fecal coli form, streptococcal, and other bacteria) in accordance with AWWA EWW. The testing method used shall be either the multiple-tube fermentation technique or the membrane-filter technique. Disinfection shall be repeated until tests indicate the absence of coliform organisms (zero mean coliform density per 100 millilitres) in the samples for at least 2 full days. The system will not be accepted until satisfactory bacteriological results have been obtained.

### 3.13 PLUMBING FIXTURE SCHEDULE

#### P-1A WESTERN WATER CLOSET:

Elongated bowl with flush tank, supply spud, floor mounted. Seat - white plastic.

Flush Tank - An adequate quantity of water shall be provided to flush and clean the fixture served. The water supply to flush tanks equipped for manual flushing shall be controlled by a float valve or other

automatic device designed to refill the tank after each discharge, and to completely shut off the water flow to the tank when the tank is filled to operational capacity.

#### P-3 LAVATORY:

Manufacturer's standard sink depth, enameled cast iron or vitreous china.

Faucet - Faucets shall be single control, mixing type. Faucets shall have replaceable seats and washers. Connection between valve and spout for center-set faucet shall be of rigid metal tubing. Drain - Pop-up drain shall include stopper, lift rods, jam nut, washer, and tail piece.

#### P-3 A MULTI-FAUCET SINK:

Built-up concrete sink with floor drain and wall mounted faucets, size and shape as indicated on drawings.

Faucet - Faucets shall be single control, mixing type. Faucets shall have replaceable seats and washers. Valves and handles shall be copper alloy. Connection between valve and spout for center-set faucet shall be of rigid metal tubing. Provide manual mixing with hot and cold water valves. See Architectural drawings for quantities.

Drain - Pipe size as indicated on Drawings.

#### P-3 B LAVATORY:

Manufacturer's standard sink depth, enameled cast iron or vitreous china.

Faucet - Faucets shall be single control, mixing type, counter mounted. Faucets shall have replaceable seats and washers. Connection between valve and spout for center-set faucet shall be of rigid metal tubing.

Drain - Pop-up drain shall include stopper, lift rods, jam nut, washer, and tail piece.

Basis of Design: Sophia G0862 with B1059 and G4751 by Ideal Standard.

#### P-4 JANITOR'S SINK:

Floor mount janitor, enameled cast iron with copper alloy rim guard. Provide hot and cold water valves with manual mixing.

Provide Janitor's sink in all large Administration and Support buildings like Community Center, Garrison and Brigade Headquarters.

P-5 SHOWER: Shower heads, other than emergency showers, shall be nonadjustable spray type.

Wall Mounted: Shower head shall be nonadjustable spray, stainless steel or chromium plated brass with ball joint. Handles shall be manufacturer's option. Control valves shall be copper alloy, nickel alloy, or stainless steel. Valves shall be mechanical mixing, with separate hot and cold water. Shower head shall be vandalproof with integral back. Each shower compartment shall be additionally furnished with a flexible 1.5 m spray hose, with hanger, attached to a hose faucet mounted below the control valve. The shower head and the spray hose shall each have a valve so flow can be diverted to either outlet.

#### P-7 EMERGENCY SHOWER AND EYE WASH ASSEMBLY:

Provide where required. See Section 11703 Safety Wash Station.

#### P-9 KITCHEN SINK:

Ledge back with holes for faucet and spout single bowl, size as indicated on Drawings, stainless steel.

Faucet and Spout - Faucets shall be cast or wrought copper alloy. Aerator shall have internal threads.  
 Handle - Cast copper alloy, wrought copper alloy, or stainless steel.

### 3.14 PERFORMANCE OF WATER HEATING EQUIPMENT

Standard rating condition terms are as follows:

EF = Energy factor, overall efficiency. SL = Standby loss in W/0.093 sq. m. based on 27 degrees C delta T, or in percent per hour based on nominal 38 degrees C delta T.

#### 3.14.1 Storage Water Heaters

##### 3.14.1.1 Electric

a. Storage capacity of 454 liters or less, and input rating of 12 kW or less: minimum energy factor (EF) shall be 0.95-0.00132V per 10 CFR 430.

b. Storage capacity of more than 454 liters or input rating more than 12 kW: maximum SL shall be 1.9 w/0.093 sq. m. per ASHRAE 90.1.

### 3.15 TABLES

TABLE I

#### PIPE AND FITTING MATERIALS FOR DRAINAGE, WASTE, AND VENT PIPING SYSTEMS SERVICE

Item # Pipe and Fitting Materials	A	B	C	D	E	F
20 Polyvinyl Chloride plastic drain, Waste and vent pipe and fittings,	X	X	X	X	X	X

ASTM D 2665, DIN 8061, DIN 8062, DIN 8063 standards ASTM F 891, (Sch 40) ASTM F 1760

Basis of Design: Pipe by Nepro Plastics, Fittings by Nibco, Charlotte Pipe and Foundry Company, or Nepro Plastics.

END OF SECTION 15000

## **SECTION 2005 – WELL FOR DRINKING WATER**

### **1.0 Description and Requirement**

The water supply well must be located no less than 100 meters away from the sewer tank and absorption well.

#### *New Water Supply Well and Pumping Systems*

- 1.1.1 Install a well for drinking water, with well casings, pumping system and drop pipe (pump column) as required.
- 1.1.2 The depth of a new well, for the purposes of tendering the Works is based on a depth of 60 meters. If the depth of the well exceeds 60 meter, the Contractor is to inform the site Supervisor and a change order for additional payment will be negotiated. If the drilled and complete well depth is less than 60 meters, the Contracting Authority will be granted a credit for the depth of well not constructed.
- 1.1.3 A hand dug shallow well will **not** be acceptable. Only a drilled well, to depths greater than 10 meters, with a minimum 3-meter length slotted screen, filter pack and minimum 5-meter sanitary seal will be accepted. See the Drawing W01 for a visual representation of the well design. The slotted screen must be placed in the water-bearing zone and the sanitary seal from the ground surface down.

#### *Vertical and Plumb Well*

The Contractor will not be paid for a finished well that is not vertical and plumb. Each well shall be constructed and casing installed plumb and true to line. No “doglegs” will be permitted. In order to ensure that the well is plumb, each well shall be tested for straightness by lowering a weighted messenger down the well casing and screen. This messenger shall be constructed of schedule 80 6-inch diameter PVC having a length of 5m. If the test demonstrates that the well is out of plumb (i.e., the weighted messenger cannot pass the entire length of casing and screen), the well shall be rejected and all costs of correcting or abandoning the well shall be paid by the Contractor. The cost to test each well shall be the full responsibility of the Contractor.

#### *Well Materials and Construction*

The well boring will be a minimum of 10-inches in diameter. The well itself must be constructed within 10-inch diameter steel temporary casing. The well casing and screen shall be steel or Schedule 80 PVC (flushed threaded) of 6-inches diameter or metric equivalent. To construct the well, place a 50 cm (~20 inches) long section of blank 6-inch diameter casing at the very bottom of the borehole (this acts as a debris trap or “sump”). Weld the 6-inch diameter slotted well screen section to this and set the slotted screen in the water-bearing zone. Weld the slotted screen properly to the solid (non-slotted) steel casing. The blank steel casing must extend up to the ground

surface. See the Drawings for a well construction detail. If PVC casing is used, the material must be flush-threaded and machine-slotted at the factory.

#### *Well Filter/Gravel Pack*

The 10-inch boring and 6-inch casing size will allow for placement of 2-inches minimum thickness of gravel pack in the annular space between the 10-inch temporary casing and well casing (steel well material). The terms "Filter Pack" and "Gravel Pack" are interchangeable – they have the same meaning. The filter (gravel) pack should extend a minimum of 1 meter above the slotted well screen. The filter pack must extend up to the bottom of the sand layer above the sanitary seal. The well must be surged for a minimum of 2 hours and additional gravel placed around the casing (between the borehole and casing) as the gravel pack settles.

#### *Sanitary Seal, Well Surge and Development*

Once the well screen and blank casing are securely placed in the well, and the gravel/filter pack is in place, surge the well for a minimum of two hours or until the gravel pack is no longer settling. Following surging of the well, and after the gravel pack is no longer settling, place a minimum layer of 1 meter of clean, fine sand on top of the filter pack. Place a bentonite layer of 0.5-meter thickness on top of the sand. A sanitary seal consisting of a lean concrete slurry, a minimum of 5 meters thick, shall be placed on top of the sand. This creates a sanitary seal that prohibits transmission of shallow contaminated water from entering the well bore.

Following construction of the well, the well shall be pumped to develop it until the water runs clear and there is no sand in the water.

#### *Pumping Systems and Wellhead Finishing*

- 1.1.4 A heavy duty submersible pump, supplied with sufficient water-proof pump cable to reach from the pump to the surface is to be provided. Splices in the pump's electrical power supply cable will not be accepted. Pumps sizing calculations and recommendation shall be provided by the Contractor to the Supervisor for approval. The Contractor will not be paid for supply of the pump unless the Supervisor has approved the pump size.
- 1.1.5 Minimum pump column pipe size shall be 2 inch or 50mm galvanized iron pipe. Provide complete pipe and fitting from well to building, buried a minimum of 1 meter deep.
- 1.1.6 Provide a check valve, drain valve and isolation valves at the well discharge point.
- 1.1.7 The well discharge point shall be installed either in a concrete vault or within a well-insulated wellhead building to provide adequate freeze protection. An unprotected/un-insulated wellhead installation will not be acceptable.

#### **1.2 Well Capacity and Water Quality Testing**

- 1.2.1 Well are to be pumped continuously for a period of 2 hours and the flow measured with tanks to indicate the production capacity of the well. The final sizing of the water storage tank shall not be determined until after the well has been tested. The Contractor is solely responsible for providing well pumps capable of pumping the well to determine its capacity.
- 1.2.2 After installing the well pump and pumping continuously, and prior to collecting water samples for laboratory analysis, the well shall be disinfected. Upon completion of well development operations, each well shall be thoroughly cleaned of all foreign substances, including tools, timbers, rope, debris of any kind, cement, oil, grease, joint dope, and scum. Casing pipe shall be thoroughly

swabbed, using alkalis as necessary, to remove any oil, grease, or joint dope.

Following the above cleaning, each well shall be chlorinated with a solution of chlorine which when mixed with a volume of water equal to that contained within the well will result in a minimum 100 mg/l concentration in all parts of the well. The Contractor will be responsible for supplying and transporting the chlorine solution to the well site. A tremie pipe should be used to place the chlorine solution in the well and insure proper distribution of the disinfectant.

The solution shall be left undisturbed for at least 16 hours and then pumped or bailed to waste by the Contractor until the discharge water is free of chlorine as indicated by negligible chlorine residual.

- 1.2.2 Water samples from the well, after pumping the disinfected well for a minimum of 2 hours will be collected. The samples shall be collected as recommended by a testing laboratory qualified to complete a drinking water panel. Minimum analyses include Total Fecal Coliform and basic minerals, including but not limited to Total Dissolved Solids, ph, Boron, Nitrate, Nitrite, Arsenic, Bromine/Bromate and Total Hardness. Water samples shall be transported to DACAAR lab in Kabul or another equally certified lab in lab-provided containers with preservatives as recommended by the lab. Prior to water quality testing, the name and location of the laboratory to be used shall be submitted to the Supervisor for approval. Test results from an unapproved lab shall result in non-payment of this item.

### **1.3 Well Rehabilitation**

If an existing well is to be used for potable water supply, it must be re-developed and water samples collected and analyses performed prior to its use. The Contractor shall surge the well for a minimum of two hours, then pump as specified above to determine the well capacity.

Wells are to be pumped continuously for a period of 2 hours and the flow measured with tanks to indicate the production capacity of the well. The final sizing of the water storage tank and pumping system shall not be determined until after the well has been tested. The Contractor is solely responsible for providing well pumps capable of pumping the well to determine its capacity.

Once the well has been re-develop to the satisfaction of the Supervisor and a properly-sized pumping system installed, meeting the specification in this section, the well shall be disinfected and water quality samples collected.

## **SECTION 7300 –BASIC MECHANICAL MATERIALS AND METHODS**

### **1.0 Description and Requirement**

#### **1.2 RELATED REQUIREMENTS**

This section applies to all sections of Division 15, "Mechanical" of this project specification, unless specified otherwise in the individual section.

#### **1.3 DOCUMENTATION FOR PROPOSED VARIANT PRODUCTS**

For products not explicitly named in the specification that meet product requirement criteria named herein, product data shall be submitted for review. Product information will be provided to establish that proposed product meets the requirements of this specification and has the indicated qualities related to type, function, dimension, in-service performance, physical properties, appearance, or other relevant characteristics that equal or exceed those of specified product. Product is consistent with the Contract Documents and will produce the indicated results, and is compatible with other portions of the Work.

#### **1.4 QUALITY ASSURANCE**

##### **1.4.1 Material and Equipment Qualifications**

Provide materials and equipment that are standard products of manufacturers regularly engaged in the manufacture of such products, which are of a similar material, design and workmanship. Standard products shall have been in satisfactory commercial or industrial use for 2 years prior to bid opening. The 2-year use shall include applications of equipment and materials under similar circumstances and of similar size. The product shall have been for sale on the commercial market through advertisements, manufacturers' catalogues, or brochures during the 2-year period.

##### **1.4.2 Alternative Qualifications**

Products having less than a two-year field service record will be acceptable if a certified record of satisfactory field operation for not less than 6000 hours, exclusive of the manufacturer's factory or laboratory tests, can be shown.

##### **1.4.3 Manufacturer's Nameplate**

Each item of equipment shall have a nameplate bearing the manufacturer's name, address, model number, and serial number securely affixed in a conspicuous place; the nameplate of the distributing agent will not be acceptable.

#### **1.5 DELIVERY, STORAGE, AND HANDLING**

Handle, store, and protect equipment and materials to prevent damage before and during installation in accordance with the manufacturer's recommendations, and as approved by the Government. Replace damaged or defective items.

#### **1.6 ELECTRICAL REQUIREMENTS**

Furnish motors, controllers, disconnects and contactors with their respective pieces of equipment. Motors, controllers, disconnects and contactors shall conform to and have electrical connections provided under Section 16402, "Interior Distribution System." Furnish internal wiring for components of packaged equipment as an integral part of the equipment. Extended voltage range motors will not be permitted. Controllers and contactors shall have a maximum of 220volt control circuits, and shall have auxiliary contacts for use with the controls furnished. When motors and equipment furnished are larger than sizes indicated, the cost of additional electrical service and related work shall be included under the section that specified that motor or equipment. Power wiring and conduit for field installed equipment shall be provided under and conform to the requirements of Section 16402, "Interior Distribution System."

#### **1.7 INSTRUCTION TO GOVERNMENT**



When specified in other sections, furnish the services of competent instructors to give full instruction to the Government in the adjustment, operation, and maintenance, including pertinent safety requirements, of the specified equipment or system. Instructors shall be thoroughly familiar with all parts of the installation and shall be trained in operating theory as well as practical operation and maintenance work. Instruction shall be given during the first regular work week after the equipment or system has been accepted and turned over to the Government for regular operation. The number of man-days (8 hours per day) of instruction furnished shall be as specified in the individual section. When more than 4 man-days of instruction are specified, use approximately half of the time for classroom instruction. Use other time for instruction with the equipment or system. When significant changes or modifications in the equipment or system are made under the terms of the contract, provide additional instruction to acquaint the operating personnel with the changes or modifications.

## 1.8 ACCESSIBILITY

Install all work so that parts requiring periodic inspection, operation, maintenance, and repair are readily accessible. Install concealed valves, expansion joints, controls, dampers, and equipment requiring access, in locations freely accessible through access doors.

## PART 2 PRODUCTS

### 2.1 MANUFACTURER

Basis of Design: As indicated in this section. Acceptable Manufacturers:

1. Basis of Design manufacturers.
2. Equivalent product complying with requirements of this specification for proposed variant products.

## PART 3 EXECUTION

### 3.1 PAINTING OF NEW EQUIPMENT

New equipment painting shall be factory applied or shop applied, and shall be as specified herein, and provided under each individual section.

#### 3.1.1 Factory Painting Systems

Manufacturer's standard factory painting systems may be provided subject to certification that the factory painting system applied will withstand 125 hours in a salt-spray fog test, except that equipment located outdoors shall withstand 500 hours in a salt-spray fog test. Salt-spray fog test shall be in accordance with ASTM B 117, and for that test the acceptance criteria shall be as follows: immediately after completion of the test, the paint shall show no signs of blistering, wrinkling, or cracking, and no loss of adhesion; and the specimen shall show no signs of rust creep age beyond 3 mm on either side of the scratch mark.

The film thickness of the factory painting system applied on the equipment shall not be less than the film thickness used on the test specimen. If manufacturer's standard factory painting system is being proposed for use on surfaces subject to temperatures above 50 degrees C, the factory painting system shall be designed for the temperature service.

#### 3.1.2 Shop Painting Systems for Metal Surfaces

Clean, pre-treatment, prime and paint metal surfaces; except aluminium surfaces need not be painted. Apply coatings to clean dry surfaces. Clean the surfaces to remove dust, dirt, rust, oil and grease by wire brushing and solvent degreasing prior to application of paint, except metal surfaces subject to temperatures in excess of 50 degrees C shall be cleaned to bare metal.

Where more than one coat of paint is specified, apply the second coat after the preceding coat is thoroughly dry. Lightly sand damaged painting and retouch before applying the succeeding coat. Color of finish coat shall be aluminium or light gray.

- a. Temperatures Less Than 50 Degrees C: Immediately after cleaning, the metal surfaces subject to temperatures less than 50 degrees C shall receive one coat of pretreatment primer applied to a

minimum dry film thickness of 0.0076 mm, one coat of primer applied to a minimum dry film thickness of 0.0255 mm; and two coats of enamel applied to a minimum dry film thickness of 0.0255 mm per coat.

b. Temperatures Between 50 and 205 Degrees C: Metal surfaces subject to temperatures between 50 and 205 degrees C shall receive two coats of 205 degrees C heat-resisting enamel applied to a total minimum thickness of 0.05 mm.

c. Temperatures Greater Than 205 Degrees C: Metal surfaces subject to temperatures greater than 205 degrees C shall receive two coats of 315 degrees C heat-resisting paint applied to a total minimum dry film thickness of 0.05 mm.

END OF SECTION 7300

## **SECTION 7301 SPLIT-SYSTEM AIR-CONDITIONING UNITS**

### **1.2 RELATED DOCUMENTS**

Drawings and general provisions of the Contract, including General and Supplementary Conditions and Division 1 Specification Sections, apply to this Section.

Approved commissioning plan for performance, acceptance and other commissioning requirements.

### **1.3 SUMMARY**

This Section includes split-system air-conditioning and heat pump units consisting of separate evaporator-fan and compressor-condenser components. Units are designed for exposed or concealed mounting, and may be connected to ducts.

Related Sections include the following:

Division 15 Section "Mechanical Vibration Isolation and Seismic Restraints" for isolation pads, spring isolators, and seismic restraints.

Division 15 Section "Control Systems Equipment" for control devices not packaged with units.

### **1.4 DEFINITIONS**

#### **1.4.1 SPLIT SYSTEM AC UNIT**

Unit shall be a split type, factory made assembly, consisting of an indoor section and an outdoor section, designed to work together to provide year round heating and cooling, air-circulating, ventilating, air-cleaning, and dehumidifying functions. The separate sections shall be standard commercial products of the same manufacturer, and shall have ratings based on their being used as matched assemblies. Minimum Coefficient of Performance (COP) shall be 2.9. Minimum Seasonal Energy Efficiency Ratio (SEER) shall be 10. Refrigerant shall be non-CFC.

a. Indoor Section Indoor section shall be a factory assembled unit consisting of indoor coil, centrifugal blower, motor, motor controls, filters, electric resistance heaters, enclosure, and condensate pan, with controls, relief devices, piping, wiring, controls and accessories required for operation. Outlet grille shall be constructed to permit adjustable directional air flow. Unit shall be wall mounted console type construction. The sound level rating shall be less than 45 decibels (dB).

b. Outdoor Section Outdoor section shall be a factory assembled unit consisting of outdoor coil, propeller type fans arranged for horizontal discharge, refrigerant circuit with filter-dryer, and hermetically sealed compressor with crankcase heater, internal overload protection and pressure relief valve, all contained in a weather resistant outer casing. Defrost controls, and necessary tubing, piping, controls, control circuits, and required accessories shall be provided. System shall be factory pre-charged with oil and refrigerant. Air inlet and discharge grilles with bird screens shall be provided. The sound level rating shall be less than 60 dB. The unit shall be mounted on a fabricated metal stand a minimum of 300 mm on a concrete pad at grade.

##### **1.4.1.1 Electrical Requirements.**

Each section shall be equipped with a main power panel and shall include complete branch circuit protection for every electrical component. Main power panel shall completely protect the unit from

primary single phasing and over current. Fuses and protective devices shall be provided by the manufacturer and installed at the factory. All components of the main power panel and all control devices shall be UL listed. Wiring shall be in accordance with UL and NFPA 70 requirements. Equipment shall operate on 220 volt, single phase, 50 hertz electrical service.

#### 1.4.1.2 Controls.

A switch with fan/off/cool/heat positions shall be mounted in the unit or with the remote thermostat. Thermostat shall be remotely mounted where shown on the drawing. Building wall penetrations shall be carefully made so as not to deteriorate the structural integrity of the wall system. The Contractor shall consult with the building manufacturer, if possible, to determine the best way to penetrate the wall. If the building manufacturer is not available, a structural engineer shall be consulted. In either case, the recommendations of the engineer shall be strictly adhered to.

#### 1.4.1.3 Submittals

The Contractor shall submit the following for the equipment to be provided under this section of the specification: manufacturer's data including performance characteristics at design conditions; catalog cuts showing dimensions, performance data, electrical requirements, compliance with standards as stated in paragraph CODES, STANDARDS AND REGULATIONS; drawings indicating location and installation details.

### PART 2 PRODUCTS

#### 2.1 MANUFACTURER

Acceptable Manufacturers:

Subject to compliance with requirements, manufacturers offering accessories that may be incorporated into the Work include, but are not limited to, the following:

- Simense (Germany)
- LG (Korea)
- Samsung (Korea)

#### 2.2 ACCESSORIES

Thermostat: Wireless infrared functioning to remotely control compressor and evaporator fan, with the following features:

Compressor time delay.

24-hour time control of system stop and start.

Liquid-crystal display indicating temperature, set-point temperature, time setting, operating mode, and fan speed.

Fan-speed selection, including auto setting.

Automatic-reset timer to prevent rapid cycling of compressor.

Refrigerant Line Kits: Soft-annealed copper suction and liquid lines factory cleaned, dried, pressurized, and sealed; factory-insulated suction line with flared fittings at both ends.

### PART 3 EXECUTION

#### 3.1 INSTALLATION

Install units level and plumb.

Install evaporator-fan components using manufacturer's standard mounting devices securely fastened to building structure.

Install roof-mounted compressor-condenser components on equipment supports specified in Division 7 Section "Roof Accessories." Anchor units to supports with removable, cadmium-plated fasteners.

Install compressor-condenser components on restrained, spring isolators with a minimum static deflection of 25 mm. Refer to Division 15 Section "Mechanical Vibration Controls and Seismic Restraints."

Connect precharged refrigerant tubing to component's quick-connect fittings. Install tubing to allow access to unit.

Refer to Section 17100 and final commissioning plan issued by the Commissioning Authority (CxA) for additional equipment testing and final acceptance requirements.

### 3.2 CONNECTIONS

Piping installation requirements are specified in other Division 15 Sections. Drawings indicate general arrangement of piping, fittings, and specialties.

Install piping adjacent to unit to allow service and maintenance.

Unless otherwise indicated, connect piping with unions and shutoff valves to allow units to be disconnected without draining piping. Refer to piping system Sections for specific valve and specialty arrangements.

Ground equipment.

Tighten electrical connectors and terminals according to manufacturer's published torque-tightening values. If manufacturer's torque values are not indicated, use those specified in UL 486A and UL 486B.

### 3.3 FIELD QUALITY CONTROL

Installation Inspection: Engage a factory-authorized service representative to inspect field-assembled components and equipment installation, including piping and electrical connections, and to prepare a written report of inspection.

Leak Test: After installation, charge system and test for leaks. Repair leaks and retest until no leaks exist.

Operational Test: After electrical circuitry has been energized, start units to confirm proper motor rotation and unit operation. Remove malfunctioning units, replace with new components, and retest. Test and adjust controls and safeties. Replace damaged and malfunctioning controls and equipment. Condition Acceptance Testing. Lubricant testing, vibration acceptance testing of fans and motors, and electrical testing of electrical controls and connections per approved commissioning plan.

### 3.4 COMMISSIONING

Verify that units are installed and connected according to the Contract Documents.

Lubricate bearings, adjust belt tension, and change filters.

Perform startup checks according to manufacturer's written instructions and do the following:

Fill out manufacturer's checklists.

Check for unobstructed airflow over coils.

Check operation of condenser capacity-control device.

Verify that vibration isolation devices and flexible connectors dampen vibration transmission to structure.

Demonstrate conformance to Performance and Condition Acceptance Testing per the approved commissioning plan.

### 3.5 DEMONSTRATION

Engage a factory-authorized service representative to train Owner's maintenance personnel to adjust, operate, and maintain units.

Train Owner's maintenance personnel on procedures and schedules for starting and stopping, troubleshooting, servicing, and maintaining units.

Review data in maintenance manuals. Refer to Division 1 Section "Contract Closeout." Schedule training with Owner, through Architect, with at least seven days' advance notice.

END OF SECTION 7301

## **SECTION 7302 AIR SUPPLY, DISTRIBUTION, VENTILATION, AND EXHAUST SYSTEM**

### 1.2 SYSTEM DESCRIPTION

#### 1.2.1 VENTILATION AND EXHAUST SYSTEMS

All fans shall be used for building ventilation and pressurization with capacities to be selected for minimum noise level generated. Unit mounted fans either used for supply or exhaust shall be centrifugal forward curved, backward inclined, or airfoil fans with non-overloading characteristics of high efficiency

and quiet running design. The fans shall be of the heavy-duty type with durable construction and proved performance in a desert environment. Each exhaust fan shall be provided with shut-off dampers which close automatically when the fan is not running. Also, each fan shall be complete with vibration isolator, external lubricators where bearings require routine lubrication, and all accessories and sound attenuators as necessary. Kitchen shall be provided with exhaust hood, with front supply slots for 100% make up air, located over major heat producing equipment. System design and installation shall be in accordance with the requirements of NFPA 96 and the recommendations of the 1999 ASHRAE Applications handbook. Each hood shall exhaust air to the outside of the facility and contain grease (washable) filters.

#### 1.2.1.1 Submittals

The Contractor shall submit the following for the equipment to be provided under this section of the specification: manufacturer's data including performance characteristics at design conditions; catalog cuts showing dimensions, performance data, electrical requirements, compliance with standards as stated in paragraph CODES, STANDARDS AND REGULATIONS; drawings indicating location and installation details.

#### 1.2.2 DESIGN CONDITIONS

The outdoor ambient design temperatures for the summer are 97° DB, 68°F WB and for the winter is 3°F. Air-conditioning in the selected offices and bedrooms to maintain 23.8°C (75°F) in summer and 21.1°C (70°F) in winter.

Heating in all offices, barracks, and other occupancies shall be 21.1°C (70°F) to maintain indoor temperature in winter.

Noise levels inside occupied spaces generated by HVAC systems shall not exceed NC 35.

#### 1.3 DELIVERY AND STORAGE

Equipment delivered and placed in storage shall be stored with protection from the weather, humidity and temperature variations, dirt and dust, or other contaminants. Additionally, all pipes shall either be capped or plugged until installed.

#### 1.4 FIELD MEASUREMENTS

After becoming familiar with all details of the work, the Contractor shall verify all dimensions in the field, and shall advise the Government of any discrepancy before performing the work.

#### 1.5 MATERIAL AUTHENTICATION DATA INCLUDED IN DESIGN ANALYSIS

The following is submitted in accordance with bid documents. It is included in the Design Analysis for this project.

##### SD-03 Product Data

##### Components and Equipment

Manufacturer's catalogue data included with the detail drawings for the following items. The data shall be highlighted to show model, size, options, etc., that are intended for consideration. Data shall be adequate to demonstrate compliance with contract requirements for the following:

- a. Piping Components
- b. Ductwork Components
- c. Air Systems Equipment
- d. Air Handling Units Test Procedures

Proposed test procedures for piping hydrostatic test, ductwork leak test, and performance tests of systems, at least 2 weeks prior to the start of related testing.

Diagrams:

The Proposed diagrams at least 2 weeks prior to start of related testing. System diagrams that show the layout of equipment, piping, and ductwork, and typed condensed operation manuals explaining preventative maintenance procedures, methods of checking the system for normal, safe operation, and procedures for safely starting and stopping the system shall be framed under glass or laminated plastic. After approval, these items shall be posted where directed.

#### Manufacturer's experience

Statement demonstrating successful completion of similar services on at least 5 projects of similar size and scope, at least 2 weeks prior to submittal of other items required by this section.

#### Performance Tests

Proposed test schedules for hydrostatic test of piping, ductwork leak test, and performance tests, at least 2 weeks prior to the start of related testing.

#### Field Training

Proposed schedule for field training, at least 2 weeks prior to the start of related training.

##### Performance Tests Testing, Adjusting, and Balancing

Test reports for the piping hydrostatic test, ductwork leak test, and performance tests in booklet form, upon completion of testing. Reports shall document phases of tests performed including initial test summary, repairs/adjustments made, and final test results.

Provide manuals listing step-by-step procedures required for system startup, operation, shutdown, and routine maintenance, at least 2 weeks prior to field training. The manuals shall include the manufacturer's name, model number, parts list, list of parts and tools that should be kept in stock by the Government for routine maintenance including the name of a local supplier, simplified wiring and controls diagrams, and troubleshooting guide.

Operation and Maintenance Manuals shall be as required in Section 01060: SPECIAL CLAUSE entitled OPERATION AND MAINTENANCE (O&M) DATA FOR EQUIPMENT AND SYSTEMS, and include the additional requirements as specified hereinafter. In the event of a conflict, the more detailed requirement shall apply.

## 1.6 DOCUMENTATION FOR PROPOSED VARIANT PRODUCTS

For products not explicitly named in the specification that meet product requirement criteria named herein, product data as listed in article titled MATERIAL AUTHENTICATION DATA INCLUDED IN DESIGN ANALYSIS shall be submitted for review. Product information will be provided to establish that proposed product meets the requirements of this specification and has the indicated qualities related to type, function, dimension, in-service performance, physical properties, appearance, or other relevant characteristics that equal or exceed those of specified product. Product is consistent with the Contract Documents and will produce the indicated results, and is compatible with other portions of the Work.

## PART 2 PRODUCTS

### 2.1 Acceptable Manufacturers:

Greenheck (USA), Extractor (Dubai).

Equivalent product complying with requirements of this specification for proposed variant products.

## 2.2 CEILING AND WALL FANS

### 2.2.1 Ceiling Fan

Provide 1,500 mm blade ceiling fans at one per 40 square meters of floor space. Fans shall have reversible motors. Center or distribute evenly in room. Coordinate placement with the lighting plan to

prevent conflict or casting shadows. Fan mount shall be flush, standard, or angle mount depending on ceiling height. Fan shall be mounted such that the fan blade is approximately 2,440 mm above the finished floor. The fan shall be provided with out light kit. The finish shall be factory painted white. The controls shall be from either a single pole switch or from two 3 way switches to provide on/off operation. The electrical supply shall be 220volts, single phase, and 50 hertz. Install per manufacturers' instructions.

## 2.2.2 Submittals

The Contractor shall submit the following for the equipment to be provided under this section of the specification: manufacturer's data including performance characteristics at design conditions; catalog cuts showing dimensions, performance data, electrical requirements, compliance with standards as stated in paragraph CODES, STANDARDS AND REGULATIONS; drawings indicating location and installation details.

## 2.10 AIR SYSTEMS EQUIPMENT

### 2.10.1 Fans

Fans shall be tested and rated according to AMCA 210. Fans may be connected to the motors either directly or indirectly with V-belt drive. V-belt drives shall be designed for not less than 120 percent of the connected driving capacity. Motors for V-belt drives shall be provided with adjustable rails or bases. Removable metal guards shall be provided for all exposed V-belt drives, and speed-test openings shall be provided at the center of all rotating shafts. Fans shall be provided with personnel screens or guards on both suction and supply ends, except that the screens need not be provided, unless otherwise indicated, where ducts are connected to the fan. Fan and motor assemblies shall be provided with vibration-isolation supports or mountings as indicated. Vibration-isolation units shall be standard products with published loading ratings. Each fan shall be selected to produce the capacity required at the fan static pressure indicated.

#### 2.10.1.1 Ceiling Exhaust Fans

Suspended cabinet-type ceiling exhaust fans shall be centrifugal type, direct-driven. Fans shall have acoustically insulated housing. Integral backdraft damper shall be chatter-proof. The integral face grille shall be of egg-crate design or louver design. Fan motors shall be mounted on vibration isolators. Unit shall be provided with mounting flange for hanging unit from above.

#### 2.10.2.1 Holding Frames

Frames shall be fabricated from not lighter than 1.6 mm (16 gauge) sheet steel with rust-inhibitor coating. Each holding frame shall be equipped with suitable filter holding devices. Holding frame seats shall be gasketed. All joints shall be airtight.

## 2.11 FACTORY PAINTING

Units which are not of galvanized construction according to ASTM A 123/A 123M or ASTM A 924/A 924M shall be factory painted with a corrosion resisting paint finish. Internal and external ferrous metal surfaces shall be cleaned, phosphatized and coated with a paint finish which has been tested according to ASTM B 117, ASTM D 1654, and ASTM D 3359. Evidence of satisfactory paint performance for a minimum of 125 hours for units to be installed indoors and 500 hours for units to be installed outdoors shall be submitted. Rating of failure at the scribe mark shall be not less than 6, average creepage not greater than 3 mm.. Rating of the inscribed area shall not be less than 10, no failure. On units constructed of galvanized steel which have been welded, exterior surfaces of welds or welds that have burned through from the interior shall receive a final shop docket of zinc-rich protective paint according to ASTM D 520 Type I.

## 2.12 TESTS ON COMPLETION

After completion of the work, the Contractor shall demonstrate to the Contracting Officer that the installation is adjusted and regulated correctly to fulfill the function for which it is intended. The Contractor shall test, adjust, balance and regulate the section or sections of concern as necessary until the required conditions are obtained. Include tests for all interlocks, safety cutouts and other protective devices to ensure proper function. All such tests shall be carried out and full records of the values

obtained shall be prepared along with the final settings and submitted to the Contracting Officer in writing.

END OF SECTION 7302

## SECTION 7303 FIRE EXTINGUISHING SYSTEMS

### 1.2 FIRE EXTINGUISHERS SYSTEM DESIGN

Design for fire extinguishers systems is in accordance with the required and advisory provisions of NFPA 10 and manufacturer's recommendations.

#### 1.2.1 Location of Fire Extinguisher

Locations of fire extinguishers shall comply with that permitted by NFPA 10 and manufacturer's recommendations.

### 1.3 QUALITY ASSURANCE

The types of extinguishers which are locally available will be provided and installed at locations specified in the design drawings.

## PART 2 PRODUCTS

2.2.1 The Portable fire extinguishers shall be Multi-Purpose Dry chemical rated, 4A:80B:C. It is wall mounted on hanger hooks with at least 12 inches clearance from the floor in easily accessible locations.

## PART 3 EXECUTION

### 3.1 INSTALLATION

Installation, workmanship, is to be as per the design drawings and specifications of the projects.

END OF SECTION 7303



## **SECTION 16000 ELECTRICAL WORKS**

### **SECTION 17000 GENERAL INFORMATION AND REQUIREMENTS OF ELECTRICAL WORKS**

#### **1.1 Electrical Work.**

1.1.1 Unless otherwise specified includes the supply, installation, testing and commissioning of the complete electrical systems, equipment and materials shown on the Drawings and/or described in the Specification together with all associated ancillary work, support work and builders work in connection.

#### **1.2 Incoming Power Supply**

1.2.1 Incoming Power Supply and Connection which will be provided by authority at 20KV.

1.2.2 It shall be the full responsibility of the Contractor to coordinate with authority, for the existing nearest tie-in manhole of MV network in order to ensure all necessary electrical connection between MV network and the transformer room of the project. No variation order shall be accepted with respect to interface with authority after contract award.

1.2.3 Medium voltage switchgear and MV/LV dry type transformers shall be in conformity with relevant European IEC Standards in order to be compatible with prevailing voltage frequency (cycle) and available grid supply network.

#### **1.3 Telephone Public Exchange Lines**

1.3.1 will be connected the premises by the telecom network in site. Contractor shall do necessarily follow up with Authority and secure the required authority approvals for the telephone system.

#### **1.4 Motors and Other Electrically Operated Equipment**

1.4.1 All electrical work from and including motor control centers/panels to and including motors and other electrically operated equipment, which is included in the Specification for Mechanical Work or other work, does not form part of the Electrical Work, unless otherwise noted.

1.4.2 Unless otherwise noted on drawings the Motor Control Centers / Panels of the following Mechanical System Motors are included in the Electrical works.

1.4.2.1 Fresh air fans

1.4.2.2 Exhaust fans

- 1.4.2.3 Chilled Water Pumps
- 1.4.3 Unless otherwise noted on drawings the following motor control panels / centers are not included in Electrical works, but their incoming and outgoing feeders are included in Electrical works.
  - 1.4.3.1 A/H units
  - 1.4.3.2 All pumps except chilled water pump
  - 1.4.3.3 All VFDS
- 1.4.4 Power supply to motors and other electrically operated equipment, which are not connected to a motor control center/panel, is included in the Electrical Works and comprises power supply to terminal box on equipment or nearby disconnecting or starting device, and includes the disconnecting device, if individually provided, but not the starting device or combination starter.
- 1.5 Contractor**
  - 1.5.1 will undertake detailed design of the systems that are specified in the form of "performance specifications" in accordance with the criteria stated in the Specifications and as shown on the Drawings. Detailed design drawings / shop drawings / as built drawings design will be submitted for approval. Contractor will also undertake all necessary coordination with relevant authorities having jurisdiction prior to completing the design.
- 1.6 The Contractor Shall Also:**
  - 1.6.1 The contractor has to visit the site and liaise with concerned departments for verification of any existing Buried services such as Electrical Underground cables / Communication cables etc. and should such services exist, within the Project Site layout limits, then the contractor has to include such prices in the tender for rerouting of such services. No claims for the damages or rerouting of services or any delays for obstruction of construction works, will be accepted after awarding the contract.
  - 1.6.2 Temporary electrical supply during construction of works.
  - 1.6.3 Contractor has to arrange the necessary Authority approvals and as-built drawing approvals from the relevant authorities.
  - 1.6.4 Arranging and carry out the necessary Inspections and Approvals for the Electrical Installations, Communication Installations and Fire Alarm & Firefighting Installations.

- 1.6.5 Arranging Permanent Electrical Power supply and allow for adequate & Appropriate Cable glands & Lugs etc. for Power cables connections for the Electrical substation.
- 1.6.6 Builders works, Ducts, Inserts, sleeves etc. required for work.
- 1.6.7 Co-ordination with all other related trades and services
- 1.6.8 As-built drawings, Operation & Maintenance manuals, Spares, other related project record documentations during Handing over of the project
- 1.6.9 Training of Employers Staff for the operation of each system are installed.
- 1.6.10 General Requirements
- 1.7 Installation Generally:**
  - 1.7.1 Carry out electrical work in accordance with the Drawings, Specification and Regulations, ensuring compliance with design and performance requirements, to provide safe and protected systems with equipment readily accessible for operation, maintenance and repair. Installations are to be complete, ready for operation and fully integrated and coordinated with all other work.
  - 1.7.2 Installations are to be carried out by qualified personnel
  - 1.7.3 Provide accessories necessary to complete the installations, of the types specified or recommended for the purpose by the manufacturer of the equipment or accessories.
- 1.8 Equipment Spaces and Rooms**
  - 1.8.1 Check that dimensions, structure, ventilating and cooling arrangements and other provisions in equipment spaces and rooms are suitable for installation, operation and maintenance of proposed equipment. Note any discrepancies on the shop and construction drawings.
- 1.9 Power Supply**
  - 1.9.1 liaise with the authority to confirm and execute as required by authority.
  - 1.9.2 Characteristics of supply and system grounding.
  - 1.9.3 Space requirements and associated builders work Civil and MEP for the Authority's installations.
  - 1.9.4 Make necessary arrangements at the earliest opportunity to ensure connection as and when required, and inform the Engineer in the event of any foreseen delay.
- 1.10 Telephone Public Exchange Lines**

1.10.1 liaise with the Local Authority to confirm location of connection of public telephone exchange lines into the premises.

### 1.11 Systems Used Before Substantial completion

1.11.1 for the benefit of the Contractor are to have all consumable elements, such as lamps etc. and defective equipment replaced by new, within 7 days prior to the date of substantial completion.

### 1.12 Design Conditions

#### 1.12.1 Nominal Characteristics of Power Supply and Distribution

Are as follows:

medium voltage: 20 KV currently three phases, 3 wire low resistance neutral grounding

low voltage: 400/230 V, three phase, four wire,

. Solidly ground neutral

Frequency: 50Hz.

### 1.13 Distribution Systems

Are to be supplied or derived from the voltage system previously described, as shown on the Drawings, or as otherwise specified.

### 1.14 Equipment

Is to be designed for the system voltage and frequency previously described, unless otherwise specified. Special provisions are to be made for equipment sensitive to power supply frequency and voltage variations and for equipment operated at other voltages/frequencies or by direct current sources.

### 1.15 Climatic Condition

Equipment, including transformers, switchgear, cables, relays, lighting fixtures, motors etc., is to be designed and derated for continuous and trouble-free service under the following climatic conditions

Maximum ambient temperature summer	: +40 deg. C
Minimum ambient temperature winter	: -20 deg. C
Maximum ambient temperature in plant room	: 30 deg. C
Maximum ambient temperature in plant room with A/C	: 21 ± 1 deg. C

### 1.16 Regulations

Carry out electrical work in accordance with the current issue of the local codes of practice the IEC 60304, where not in contradiction with the local codes of practice and regulations, herein referred to collectively as 'the Regulations'.

### **1.17 Conflict**

Should an instance occur in this specification or on the drawings in which material or construction methods called for is less than minimum requirement of the Regulations, the Engineer shall be immediately informed in writing. Consequent to Engineers approval, supply the materials and perform the work as though called for to minimum code standards.

### **1.18 Standards**

Unless otherwise specified, equipment and materials are to be manufactured and installed in compliance with the relevant recommendations of the following: NFPA: National Fire Protection Association (USA)

NEMA: National Electrical Manufacturer Association (USA) ANSI: American National Standard Institute.

UL: Underwriter's Laboratories.

IEC The International Electro-Technical Commission

ISO: The International Standardization Organization

CCITT: The International Telephone and Telegraph Consultative Committee

CCIR: The International Radio Consultative Committee

CISPR: The International Special Committee on Radio Interference

or other equal and approved standards, herein referred to as 'the Standards'. Local standards, where enforced and relevant, are to have precedence over the Standards.

### **1.19 Equipment Locations**

Shown on the Drawings indicate the approximate locations and general layout of equipment. Exact and final locations and layouts together with dimensions, weights, mounting methods and accessories, where relevant, are to be shown on the shop and construction drawings.

### **1.20 Wiring Layouts**

Shown on the Drawings are to be used as a guide only to defining basic positions, circuiting, loading and switching arrangements. Actual layouts and details of routing of circuits (grouping of circuits in one conduit) are to be shown on the shop and construction drawings, including coordination to avoid interference with structural works.

### **1.21 Wiring Layouts**

shown on the Drawings for work not included in the Electrical Work, such as motor control centers/panels, cables to motors and other similar electrically operated equipment are shown for convenience and reference only.

### **1.22 Symbols**

In order to provide sufficient detail and a minimum degree of clarity on the drawings, the symbols used for the various electrical devices, particularly wall-mounted devices, take up more space on the drawings than the device does on the wall. Because of drafting limitations these locations must be considered as being symbolic rather than exact physical locations of

the devices. The devices shall be installed with prime regard for convenience of operation and the proper usage of the wall space rather than to coincide with the scaled locations of the symbols. In locating the outlets, follow the criteria provided on detail drawings where provided, and coordinate with furniture.

Do not scale from design drawings.

## **2. Equipment and Materials**

### **2.1 Availability**

Confirm availability of equipment and materials proposed for use in the work prior to submission for approval. If, after approval, equipment or materials cease to be available, submit alternative items of equal quality and type for approval.

### **2.2 Acceptance by Authority**

Confirm that proposed equipment and material characteristics where required are compatible with the requirements of the Local Power Authority or other authorities having jurisdiction and are acceptable to them. Inform the Engineer of any modifications necessary to comply with the Local Power Authority's requirements.

### **2.3 Manufacturers' Standards**

Equipment is to be the latest standard product of the manufacturer. Component parts are to be the product of a single manufacturer, unless otherwise approved and provided that components made by other manufacturers are of a standard design and are interchangeable.

### **2.4 Approved Manufacturer's**

listing of approved manufacturers in the Specification does not necessarily constitute approval of their standard products as equal to those specified. Ascertain that listed manufacturers are able to supply equipment and material in conformity with the Specification.

### **2.5 Factory Assembly**

Equipment generally is to be supplied in complete factory assembled units ready for installation on site. Dis-assembly necessary for transportation or other purposes is to be arranged to limit site work to simple re- assembly and inter-wiring of control and power cabling.

### **2.6 Storage of Materials**

Equipment and materials are to be stored in an approved location, under cover, free from humidity, dust, debris and rodents. Equipment sensitive to heat and humidity is to be kept in climatically conditioned areas until installed and handed over.

### **2.7 Defective Equipment**

The Employer reserves the right to operate operable defective equipment during the Defects Liability Period until it can be removed from service for repair or replacement.

### **2.8 Warranty**

Where required by the Specification, provide a warranty, signed by the manufacturer (including his agreement to replace promptly, defective equipment or parts thereof, as instructed by the Engineer) covering materials and workmanship for the period stated in the Specification, starting at substantial completion. The Contractor is to assign the benefits of such warranty to the Employer.

## **2.9 Spare Parts**

Not later than the date of substantial completion, provide spare parts required by the Specification, together with suitable means of identifying, storing and securing same.

## **2.10 Tools and Instruments**

Not later than the date of substantial completion, provide sets of tools and instruments required by the Specification, together with suitable means of identifying, storing and securing same.

## **2.11 Label and Identify**

All equipment, instruments, control and electrical devices etc. to indicate duty, service or function, to the satisfaction of the Engineer. Labels are to be laminated plastic or anodized aluminum discs with black surface and white core with incised lettering in local language & English. Alternative methods of labeling may be submitted for approval. Fix labels with non-corrodible screws to equipment, or to adjacent permanent surfaces or as approved by the Engineer.

## **2.12 Equipment Nameplates**

Are to be non-corroding, robust metal, inscribed in English, and firmly fixed to equipment at factory. Nameplates are to indicate name and address of manufacturer, model, serial number, basic characteristics and ratings of equipment and are to include elementary diagrams etc., all in accordance with the Standards.

## **2.13 Fireproofing**

Where cables, cable trays, bus ducts or conduits pass through floors and fire rated walls, pack space between wiring and sleeve full with materials and seal with approved caulking compound.

## **3. Submission**

### **3.1 Generally**

Submit for approval, manufacturers' technical literature, shop and construction drawings and other information required by the Specification, before ordering equipment or materials and before executing any related work on site.

### **3.2 Coordination Study**

And deliverables required from contractor a short circuit and protection coordination study, for the electrical distribution network, is to be carried out by the contractor and submitted to the Engineer for approval.

3.2.1 Contractor shall submit the following as per IEC:

3.2.1.1 Cable sections calculations.

3.2.1.2 Voltage drop (maximum permissible value being 5 % Unless otherwise indicated).

3.2.1.3 Short circuit interrupting capacity values.

### **3.3 Technical Literature**

Is to include detailed manufacturers' specifications and original catalogues or catalogue cuts, characteristics, model number, application and operating criteria of all equipment and materials, together with other information necessary to satisfy the Engineer that proposed equipment and systems are suitable and adequate.

### **3.4 Shop and Construction Drawings**

Are to demonstrate to the Engineer that the design requirements are understood by indicating all equipment and material proposed to be supplied and installed and by detailing fabrication and installation methods proposed to be used. Shop and construction drawings are to clearly state the name and location of the work, the names of the Engineer and Contractor, submission date, cross- references to the Drawings and Specification and the specific reference number, location, service and function of each item.

### **3.5 Shop and Construction Drawings**

3.5.1 Are to be submitted at a scale of 1:100 for general layout plans, and 1:10, 1:20 or

1:50 as approved by the Engineer for sections, details, elevations, congested layouts, etc. Drawings shall include but not be limited to the following:

3.5.1.1 Details of electrical installations in conjunction with all trades concerned, showing sleeves and openings for passage through floor structure.

3.5.1.2 Composite construction drawings fully dimensioned, in metric, showing locations of cables, conduits, bus ducts, shafts, mechanical and electrical equipment rooms, ceiling spaces and all other critical locations

3.5.1.3 Plans showing equipment layouts including all details pertaining to clearances, access, sleeves, electrical connections, location and elevation of pipes, ducts, conduits, etc.

3.5.1.4 Plans, sections and elevations of electrical spaces to illustrate compliance with

Standards for allocation of spaces for maintenance, movement, installation... etc.

### **3.6 List of Proposed Manufacturers**

3.6.1 of all equipment and materials, including all items for which choice of manufacturer is at the discretion of the Contractor, is to be submitted for approval.

### **3.7 Assembled Equipment**

any assembled equipment to be supplied for the project is to be assembled by the manufacturer or his authorized assembler. Contractor is to submit the necessary documents to substantiate the above including the assembler staff training, quality control, etc. The



Engineer reserves the right to reject any local assembler if the information submitted is not sufficient. The Engineer's decision in that respect is final and not subject to discussion.

### **3.8 Test Certificates and Reports**

Submit manufacturers type and routine test certificates and reports for equipment and devices. Complete test results are to be submitted in clearly identified and organized booklets, indicating item of equipment, make, model, type, date of tests, type of tests, descriptions and procedures. Include in the test reports the Quality Assurance Certification, the standards to which the equipment comply, and the standards to which the equipment was tested.

### **3.9 Factory Testing**

For locally manufactured/assembled equipment is to comply with the relevant standards recommendations and are to be witnessed by the Engineer. If the manufacturers test certificates/tests are not complying with the standards, then independent laboratory tests are to be carried out on equipment in accordance with the Specification and the Standards, and as required by the Engineer. The Engineer's decision in that respect is final and not subject to discussion.

### **3.10 Spare Parts Schedules**

Submit with the Tender itemized schedules of spare parts to be provided, as required by the Specification, and state against each item the manufacturer's unit price including packaging and delivery to site.

### **3.11 Tools and Instruments Schedules**

submit with the Tender itemized schedules of tools and instruments to be provided, as required by the Specification, and state against each item the manufacturer's unit price including packaging and delivery to site.

### **3.12 Labeling Schedule**

Submit for approval, prior to installation, a schedule of all equipment and devices to be labeled and the suggested details, lettering, position and fixing methods of each label indicating its application.

### **3.13 Samples**

Submit samples of all equipment and materials for approval. Major items of equipment for which samples cannot be submitted are to be demonstrated in existing installations or by manufacturers information, test certificates and reports

## **Special Requirements for Electronic Equipment**

### **3.14 Construction**

Electronic components of communication systems, and CCTV systems and special systems as well as electronic components forming part of the power distribution system are to be solid-state integrated construction, unless otherwise approved.

### **3.15 Temperature Limits**

Manufacturer is to indicate maximum and minimum ambient temperatures acceptable for the equipment to operate continuously and normally and beyond which electronic components may suffer permanent damage. Contractor is to coordinate the air conditioning requirements for the rooms where the equipment is located. Inform the Engineer of any special requirements or discrepancies for a decision.

### **3.16 Alternative Electronic Equipment**

Maybe submitted for approval, provided such equipment meets or exceeds the functional capabilities and/or performance parameters of the equipment specified. Proposals for alternative equipment will be considered only if accompanied by the following information:

- List of operational characteristics and performance parameters
- List of differences in operation and performance between proposed and specified equipment
- List of changes required and resulting implications
- Drawings indicating changes required to system wiring
- Statement of advantages of proposed equipment over that specified.

### **3.17 Protection**

Solid-state equipment under normal conditions of operation is to withstand any surges, which might be produced by sudden mains or standby power switching operations. Protective devices are to be provided to protect against surges, failure of output stages due to open circuit, short-circuit or miss-match. Comply with IEC standards and/or with IEEE standard 472 (ANSI/IEEE C37.90 Guide for Surge Withstand Capability Tests". System/equipment which may be adversely affected by short duration power blackouts shall be capable of riding through such a disturbance by having an internal battery back up to the memory / microprocessor, etc.

### **3.18 Indicator Lights**

Other than LV pilot lamps are to be light emitting diodes (LEDs).

### **3.19 Electromagnetic Relays**

And control/small power transformers are to be designed to withstand the 500 V a.c. test voltage between winding and winding or winding and core.

### **3.20 Dust Covers**

Easily removable for inspection and servicing, are to be provided for all relays and sensitive elements.

### **3.21 Outdoor Equipment**

Is to be designed for maximum ambient temperature in direct sun and is to be protected/enclosed, as applicable, against dust and weather conditions.

### **3.22 External Interferences**

Carry out field investigations and tests to determine possible interference from outside sources. Design electronic equipment to ensure trouble - free operation.

### **3.23 Segregation of Wiring**

Design wiring so that low current circuits are segregated from power wiring, using different conduits and wire ways for the purpose.

Composite wiring is acceptable for the same system in accordance with the relevant codes. Cable insulation is to be same grade for all conductors in a common enclosure.

### **3.24 Power Supply Units**

For low current systems which are fed from the LV supply are to be independently fused on the live conductor and are to have front panel mains indicator light, on/off switch and standard cartridge type fuse holder. Blown fuse indicator lamp is to be provided when fuse does not have an indicator.

## **4. Tests On Site Records**

Training and maintenance.

### **4.1 Tests on Site.**

4.1.1 Carry out inspection and acceptance tests on site on each complete system, before final placement into service, in accordance with the Regulations and Standards, as described in the Specification and required by the Engineer.

4.1.2 Test Schedules and Procedures

Are to be submitted for approval and are to include details of testing equipment to be provided.

4.1.3 Witnessing

Inspection and acceptance tests are to be carried out in the presence of the Engineer, and when required, by an authorized representative of the Local Power Authority.

4.1.4 Visual Inspection

visually check proper installation, connections and nameplate data before testing.

### **4.2 Insulation Resistance.**

4.2.1 Test the feeders, lighting and power circuits, motors and other power equipment of low voltage installations with a megger of not less than 500 V d.c for installations rated up to 500 V (r.m.s. value of a.c. supply) and 1000 V d.c. for installations rated above 500 V up to 1000 V. and as required by the particular Section of the Specification.

4.2.2 Insulation Resistance

4.2.3 unless otherwise specified or approved, test the circuit insulation resistance related to communications and security systems with a megger of not less than 500 V operating voltage, with equipment disconnected.

4.2.4 Continuity:

Test all feeders and circuits for continuity.

4.2.5 Operational Tests

Carry out operational tests on all equipment and complete systems to verify proper performance in compliance with the Specification. Tests are to be carried out under normal operating conditions for not less than 3 days and as required by the Engineer.

4.2.6 Specific Tests

Carry out specific tests required by the Specification and any other tests required by the Engineer to verify compliance of the installations with the Specification.

4.2.7 Voltage Checks

Perform voltage checks throughout the building and if directed by the Engineer, adjust the transformer tap settings where a transformer is provided on the supply end, or report to power authority for adjustment necessary.

4.2.8 Current Checks

In cooperation with the mechanical sub-contractor, take clip-on ammeter readings on all phases of all mechanical equipment motors with motors operating under full load conditions. Test readings shall be submitted to the Engineer.

## **5. Records:**

### **5.1 Generally:**

Not later than the date of substantial completion, provide the Engineer with the required copies of all approved as-installed drawings, test records, manufacturers' guarantees and warranties, operating and maintenance manuals and other records required by the Specification.

### **5.2 Presentation of Records:**

Is to be in A4 size, plastic covered, loose-leaf ring binders or other approved binders with hard covers, that are indexed, divided and appropriately cover titled. Drawings larger than A4 size are to be folded in the binders so that they may be unfolded without being detached.

### **5.3 As-Installed Drawings:**

Are to contain the complete assembled information included on the construction drawings, prepared in the same manner, and up-dated to indicate the systems, labeling, referencing, mounting methods, routing etc. as installed. Submit complete drawings for approval. Drawings are to include but not limited to:

- Layout plans including all conduiting and wiring installations for all systems
- All changes to the work during construction including corrections that are made on floor plans and riser diagrams and detail drawings etc., as applicable.
- Exact dimensioned location of all services embedded in the structure
- Invert of all services entering and leaving the building and at property lines.
- Dimensions and elevations of underground services in relation to building at key points of every run.
- Riser diagrams for all systems

#### **5.4 Test Records**

are to include test certificates of type tests, routine tests, site tests, commissioning and performance tests and all other tests on equipment and installations described in the Specification and required by the Engineer. Information is to include test procedures and results, conditions under which tests were carried out including set points, temperatures and the like, dates, location and attendance by authorized representatives etc.

#### **5.5 Operating and Maintenance manuals**

Are to contain the following:

- Technical description of each system and item of equipment installed, written to ensure that the Employers staff fully understands the scope and facilities provided
- Diagrammatic drawings of each system indicating principal components and items of equipment
- Schedules (system by system) of equipment installed giving manufacturer, catalogue list numbers, model, rating, capacity and operating characteristics; each item is to have a unique code and number, cross- referenced to the diagrammatic drawings and layout drawings
- Name, addresses, telephone, e-mail and fax numbers of the manufacturer of every item of equipment
- Name, address, telephone and e-mail and fax numbers of equipment agents/representatives for emergency services and procedures
- Manufacturer's service manual for each major item of equipment, assembled specifically for the project, including detailed drawings, illustrations, circuit details, operating and maintenance instructions, modes of operation, control provisions, sequences and interlocks and preventative maintenance program
- Schedules of all fixed and variable equipment settings established during commissioning
- Procedures for fault finding, where applicable, data or recommended maintenance
- procedures, maintenance intervals and maintenance tools.
- All test results conducted on the relevant equipment whether at the manufacturer's place or at site.
- Manufacturers' lists of recommended spare parts for items subject to wear and deterioration, giving expected running period and indicating specifically those items, which may involve extended deliveries.

### **SECTION 18000 BASIC ELECTRICAL MATERIALS AND METHODS**

#### **PART 1 General**

## **1.1 Related Documents**

1. Drawings and general provisions of the Contract, including General and Supplementary Conditions and Division 1 Specification Sections, apply to this Section.

## **1.2 Summary**

- 1.2.1 This section includes the following:
- 1.2.1.1 Electrical equipment coordination and installation.
  - 1.2.1.2 Sleeves for raceways and cables.
  - 1.2.1.3 Sleeve seals.
  - 1.2.1.4 Common electrical installation requirements.

## **1.3 Definitions**

- 1.3.1 ATS: Acceptance Testing Specifications.
- 1.3.2 EPDM: Ethylene-propylene-diene terpolymer rubber.
- 1.3.3 NBR: Acrylonitrile-butadiene rubber.

## **1.4 Submittals.**

- 1.4.1 Product Data: For each type of product indicated.

## **1.5 Quality Assurance.**

- 1.5.1 Test Equipment Suitability and Calibration: Comply with NETA ATS, "Suitability of Test Equipment" and "Test Instrument Calibration."

## **1.6 Coordination**

- 1.6.1 Coordinate arrangement, mounting, and support of electrical equipment:
- 1.6.1.1 To allow maximum possible headroom unless specific mounting heights that reduce headroom are indicated.
  - 1.6.1.2 To provide for ease of disconnecting the equipment with minimum interference to other installations.
  - 1.6.1.3 To allow right of way for piping and conduit installed at required slope.
  - 1.6.1.4 So connecting raceways, cables, wireways, cable trays, and busways will be clear of obstructions and of the working and access space of other equipment.
- 1.6.2 Coordinate installation of required supporting devices and set sleeves in cast-in-place concrete, masonry walls and other structural components as they are constructed.
- 1.6.3 Coordinate location of access panels and doors for electrical items that are behind finished surfaces or otherwise concealed. Access doors and panels are specified in Division 8 Section "Access Doors and Frames"

## **PART 2 Products**

### **2.1 Manufacturers**

2.1.1 In other articles where titles below introduce lists, the following requirements apply to product selection:

2.1.1.1 Available Manufacturer: Subject to compliance with requirements, manufacturers offering products that may be incorporated into the Work include, but are not limited to, manufacturers specified.

2.1.1.2 Manufacturers: Subject to compliance with requirements, provide products by one of the manufacturers specified.

## **2.2 Sleeves for Raceways and Cables**

2.2.1 Steel Pipe Sleeves: ASTM A 53/A 53M, Type E, Grade B, Schedule 40, galvanized steel, plain ends.

2.2.2 Cast-Iron Pipe Sleeves: Cast or fabricated "wall pipe", equivalent to ductile-iron pressure pipe, with plain ends and integral water stop, unless otherwise indicated.

2.2.3 Sleeves for Rectangular Openings: Galvanized sheet steel with minimum 0.052 – or

0.138-inch (1.3-or 3.5mm) thickness as indicated and of length to suit application.

2.2.4 Coordinate sleeve selection and application with selection and application of firestopping specified in Division 7 Section "Firestop Systems".

## **2.3 Sleeve Seals**

2.3.1 Description: Modular sealing device, designed for field assembly, to fill annular space between sleeve and raceway or cable.

2.3.1.1 Sealing Elements: (EPDM) or (NBR) interlocking links shaped to fit surface of cable or conduit. Include type and number required for material and size of raceway or cable.

2.3.1.2 Pressure Plates: Stainless steel include two for each sealing element.

2.3.1.3 Connecting Bolts and Nuts: Stainless steel of length required to secure plates to sealing elements. Include one for each sealing elements.

## **PART 3 Execution**

### **3.1 Common Requirements for Electrical Installation**

3.1.1 Comply with NECA 1.

3.1.2 Measure indicated mounting heights to bottom of unit for suspended items and to center of unit for wall-mounting items.

3.1.3 Headroom Maintenance: If mounting heights or other location criteria are not indicated, arrange and install components and equipment to provide maximum possible headroom consistent with these requirements.

3.1.4 Equipment: Install to facilitate service, maintenance, and repair or replacement of components of both electrical equipment and other nearby installations. Connect in such a way as to facilitate future disconnecting with minimum interference with other items in the vicinity.

3.1.5 Right of Way: Give to raceways and piping systems installed at a required slope.

### **3.2 Sleeve Installation for Electrical Penetrations**

- 3.2.1 Electrical penetrations occur when raceways, cables, wire ways, cable trays, or busway penetrate concrete slabs, concrete or masonry walls, or fire rated floor and wall assemblies.
- 3.2.2 Coordinate sleeve selection and application with selection and application of fire stopping specified in "Through-Penetration Firestop Systems" Section.
- 3.2.3 Concrete Slabs and Walls: Install sleeves for penetrations unless core-drilled holes or formed openings are used. Install sleeves during erection of slabs and walls.
- 3.2.4 Use pipe sleeves unless penetration arrangement requires rectangular sleeved opening.
- 3.2.5 Rectangular Sleeve Minimum Metal thickness:
- 3.2.5.1 For sleeve cross-section rectangle perimeter less than 1270mm and no side greater than 40mm, thickness shall be 1.3mm.
- 3.2.5.2 For sleeve cross-section rectangle perimeter equal to, or greater than, 1270mm and 1 or more sides equal to or greater than 40mm, thickness shall be 3.5mm.
- a. Fire-Rated Assemblies: Install sleeves for penetrations of fire-rated floor and wall assemblies unless openings compatible with firestop system used are fabricated during construction of floor or wall.
- b. Cut sleeves to length or mounting flush with both surfaces of walls. c. Extend sleeves installed in floors 50mm above finished floor level.
- d. Size pipe sleeves to provide 6.4mm annular clear space between sleeve and raceways or cable unless sleeve seal it to be installed.
- e. Seal space outside of sleeves with grout for penetrations of concrete and masonry (and with approved joint compound for gypsum board assemblies).
- f. Interior Penetrations of Non-Fire-Rated Walls and Floors: Seal annular space between sleeve and raceway or cable, using joint sealant appropriate for size, depth, and location of joint. Refer to Division 7 Section "Joint Sealants" for materials and installation.
- g. Fire-Rated-Assembly Penetrations: Maintain indicated fire rating of walls, partitions, ceilings and floors at raceway and cable penetrations. Install sleeves and seal raceway and cable penetration sleeves with firestop materials. Comply with Division 7 Section "Through -Penetration Firestop Systems".
- h. Roof-Penetration Sleeves: Seal penetration of individual raceways and cables with flexible boot-type flashing units applied in coordination with roofing work.
- i. Aboveground, Exterior-Wall Penetrations: Seal penetrations using sleeves and mechanical sleeve seals. Select sleeve size to allow for 25-mm annular clear space between pipe and sleeve for installing mechanical sleeve seals.
- j. Underground, Exterior-Wall Penetrations: Install cast-iron "wall pipes" for sleeves. Size sleeves to allow for 25-mm annular clear space between raceway or cable and sleeve for installing mechanical sleeve seals.



### **3.3 Sleeve-Seal Installation**

3.3.1 Install to seal underground, exterior wall penetrations.

3.3.2 Use type and number of sealing elements recommended by manufacturer for raceways or cable material and size. Position raceway or cable in center of sleeve. Assemble mechanical sleeve seals and install in annular space between raceway or cable and sleeve. Tighten bolts against pressure plates that cause sealing elements to expand and make water tight seal.

### **3.4 Fire Stopping**

3.4.1 Apply fire stopping to electrical penetrations of fire-rated floor and wall assemblies to restore original fire-resistance rating of assembly. Fire stopping materials and installation requirements are specified in Division 7 Section "Firestop Systems".

### **3.5 Field Quality Control**

3.5.1 Inspect installed sleeve and sleeve-seal installations and associated fire stopping for damage and faulty work.

## **END OF SECTION**

## ***SECTION 19000- FIRE DETECTION AND FIRE ALARM SYSTEM***

### **PART 1 GENERAL**

#### **1.1 Summary**

1.1.1 Drawings and general provisions of the Contract, including General and Supplementary Conditions and Division 1 Specification Sections, apply to this Section

1.1.2 This Section includes fire alarm systems with manual stations, detectors, signal equipment, controls and devices.

#### **1.2 Definitions**

1.2.1 (M)FACP: (Main) Fire alarm control panel.

1.2.2 FARP: Fire alarm repeater panel.

1.2.3 LED: Light-emitting diode.

1.2.4 NICET: National Institute for Certification in Engineering Technologies.

1.2.5 Definitions in NFPA 72 apply to fire alarm terms used in this Section.

1.2.6 IDC (Initiating Device Circuits), NAC (Notification Appliance Circuits), SLC (Signaling Line Circuit).

#### **1.3 System Description**

- 1.3.1 General
- 1.3.1.1 The system supplied under this specification shall be a new UL Listed modular fire alarm network that uses independently addressed fire detection devices, input/output modules, and notification appliances.
- 1.3.1.2 The network shall utilize token ring, peer-to-peer communications. The network shall consist of a main panel MFACP, a repeater panel (as applicable) and remote-control panels reporting to MFACP. To enhance survivability, each panel shall be an equal, active functional member of the network, capable of making all local decisions and initiating network tasks for other panels. In the event of a panel failure or communications failure between panels, panels shall be capable of forming sub-networks and remain operational between communicating panels.
- 1.3.1.3 The system shall be fully field-programmable such that virtually any combination of system output functions may be correlated to any type of input event(s). Inputs may be combined using Boolean logic, be time dependent or under manual control, as defined by required system operation. All software operations are to be stored in a non-volatile programmable memory within the fire alarm control panels. There shall be no limit, other than maximum system capacity, as to the number of addressable devices which may be in alarm simultaneously.
- 1.3.2 Ease of maintenance shall be facilitated by the use of panel based and PC based system diagnostics.
- 1.3.2.1 The system shall automatically test smoke detector sensitivity, eliminating the need for manual sensitivity testing.
- 1.3.2.2 Ground fault detection and annunciation shall be by individual module address for supervised input and output devices.
- 1.3.2.3 System test operation shall be configurable by individual addressable devices, and not disable entire circuits.
- 1.3.2.4 The system shall be capable of generating a graphical map of all connected addressable devices to aid in circuit troubleshooting.
- 1.3.2.5 Placement supervision of addressable devices shall couple a device's location (not its address) to the programmed system response.
- 1.3.2.6 The system shall be designed, inspected, tested and approved to provide occupant notification audibility levels of 15 dBA over ambient conditions.
- 1.3.2.7 The system shall support CO and security detection devices with appropriate independent annunciation and signal processing.
- 1.3.2.8 The system shall transmit required signals to a central monitoring station.

- 1.3.2.9 System panels and annunciators shall utilize configurable message routing and selective event messaging to direct event information only to the required system displays and printers as determined by the event type and location.
- 1.3.2.10 The system shall have two-way communication (Fire Fighters Phone) between the main fire alarm control panel and emergency phone jack(s).
- 1.3.2.11 The Fire Alarm Control Panels shall be able to carry a number of loops equal to 1.25 times the number of active loops indicated on fire alarm riser.

## **1.4 Performance Requirements**

- 1.4.1 Premises protection includes all floors.
- 1.4.2 Fire alarm signal initiation shall be by one or more of the following devices:
  - 1.4.2.1 Manual stations.
  - 1.4.2.2 Heat detectors.
  - 1.4.2.3 Smoke detectors.
  - 1.4.2.4 Heat/Smoke detectors
  - 1.4.2.5 Flame detectors
  - 1.4.2.6 Verified automatic alarm operation of smoke detectors.
- 1.4.3 Fire alarm signal shall initiate the following actions as applicable:
  - 1.4.3.1 Identify alarm at the FACP.
  - 1.4.3.2 Alarm notification appliances shall operate continuously.
  - 1.4.3.3 Transmit an alarm signal to the remote alarm receiving station.
  - 1.4.3.4 Unlock electric door locks in designated egress paths.
  - 1.4.3.5 Release fire and smoke doors held open by magnetic door holders (as applicable).
  - 1.4.3.6 Switch ventilating and equipment controls to fire alarm mode.
  - 1.4.3.7 Close smoke dampers in air ducts of system serving zone where alarm was initiated.
  - 1.4.3.8 Record events in the system memory.
  - 1.4.3.9 Record events by the system printer.
- 1.4.4 System trouble signal initiation shall be by one or more of the following devices or actions:
  - 1.4.4.1 Open circuits, shorts and grounds of wiring for initiating device, signaling line, and notification-appliance circuit.
  - 1.4.4.2 Opening, tampering, or removal of alarm-initiating and supervisory signal-initiating devices.
  - 1.4.4.3 Loss of primary power at the FACP.
  - 1.4.4.4 Ground or a single break in FACP internal circuits.
  - 1.4.4.5 Abnormal ac voltage at the FACP.
  - 1.4.4.6 A break in standby battery circuitry.
  - 1.4.4.7 Failure of battery charging.
  - 1.4.4.8 Abnormal position of any switch at the FACP or annunciator.

- 1.4.4.9 Fire-pump power failure, including a dead-phase or phase-reversal condition.
- 1.4.4.10 System trouble switch off and on lamps shall be visible through the control unit door.
- 1.4.5 System Trouble and Supervisory Signal shall initiate the following Actions: Ring trouble bell and annunciate at the FACP. Record the event on system printer.
- 1.4.6 Detection zoning
- 1.4.6.1 Shall not exceed one floor level with exception for staircase well, elevator shaft and atrium
- 1.4.6.2 Any short circuit shall not lead to losing more than 6000m.sq of area
- 1.4.6.3 Maximum number of points or one detection circuit shall not exceed 128
- 1.4.6.4 A short circuit shall not lead to the loss of more than 32 points within a detection circuit.
- 1.4.7 A manual and selective (by compartment) activation of the alarm shall be made possible from a central station. The manual activation shall not initiate any interlocks related to the smoke management system (smoke evacuation, door release, etc.)

## **1.5 Submittals**

- 1.5.1 Product Data: For each type of product indicated.
- 1.5.1.1 Name and Address of the manufacturer and country of origin.
- 1.5.1.2 Detectors characteristic curves of coverage area against ceiling height and air movement speed.
- 1.5.1.3 Personal computer including dual processor type and speed, auxiliaries, software package, printer and the like.
- 1.5.2 Shop Drawings:
  - 1.5.2.1 Shop Drawings shall be approved by Fire Brigade Authorities and shall be prepared by persons with the following qualifications:
    - 1.5.2.1.1 Trained and certified by manufacturer in fire alarm system design.
    - 1.5.2.1.2 Fire alarm certified by NICET, minimum Level III.
  - 1.5.2.2 Device Address List: Coordinate with final system programming.
  - 1.5.2.3 System riser diagram with device addresses, conduit sizes, and cable and wire types and sizes.
  - 1.5.2.4 Wiring Diagrams: Power, signal, and control wiring. Include diagrams for equipment and for system with all terminals and interconnections identified. Show wiring color code.
  - 1.5.2.5 Floor plans to show all device locations including:
    - 1.5.2.5.1 Room numbers and names for all rooms to match contract drawings.

- 1.5.2.5.2 Device symbol for all pull station, NAC appliances, FACP, remote annunciator, monitoring devices and all other system components.
- 1.5.2.5.3 Circuiting information with point ID name and number.
- 1.5.2.5.4 Connections to all supervised devices such as water flow devices, air pressure switches, tamper switches etc. and all others.
- 1.5.2.6 Batteries: Size calculations.
- 1.5.2.7 Duct Smoke Detectors: Performance parameters and installation details for each detector, verifying that each detector is listed for the complete range of air velocity, temperature, and humidity possible when air-handling system is operating.
- 1.5.2.8 Ductwork Coordination Drawings: Plans, sections, and elevations of ducts, drawn to scale and coordinating the installation of duct smoke detectors and access to them. Show critical dimensions that relate to placement and support of sampling tubes, the detector housing, and remote status and alarm indicators. Locate detectors according to manufacturer's written recommendations.
- 1.5.2.9 System Operation Description: Detailed description for this Project, including method of operation and supervision of each type of circuit and sequence of operations for manually and automatically initiated system inputs and outputs. Manufacturer's standard descriptions for generic systems are not acceptable.
- 1.5.2.10 Cause and Effect Matrix: Show in detailed matrix format, the effect of every initiating device on the MFAC, notification devices and all system peripherals.
- 1.5.3 Qualification Data: For Installer (Include list of completed projects).
- 1.5.4 Field quality-control test reports.
- 1.5.5 Product and Installer certificates: to comply with requirements.
- 1.5.6 Operation and Maintenance Data: For fire alarm system to include in emergency, operation, and maintenance manuals. Comply with NFPA 72, Appendix A, recommendations for Owner's manual. Include abbreviated operating instructions for mounting at the FACP.
- 1.5.7 Submittals to Authorities Having Jurisdiction: In addition to distribution requirements for submittals specified in Division 1 Section "Submittals," make an identical submittal to authorities having jurisdiction. To facilitate review, include copies of annotated Contract Drawings as needed to depict component locations. Resubmit if required to make clarifications or revisions to obtain approval. On receipt of comments from authorities having jurisdiction, submit them to Architect for review.
- 1.5.8 Sound levels: measure and submit audible sound levels. Verify that 15dB above ambient noise level or 5dB above the maximum noise level that could occur at the location for 60s or more but not greater than 120dB are achieved.

1.5.9 Documentation:

1. Approval and Acceptance: Provide the "Record of Completion" form according to NFPA 72 to Owner, Architect, and authorities having jurisdiction.
  2. Record of Completion Documents: Provide the "Permanent Records" according to NFPA 72 to Owner, Architect, and authorities having jurisdiction.
- 1.5.9.1.1 Hard copies on paper to Owner, Architect, and authorities having jurisdiction.
- 1.5.9.1.2 Electronic media may be provided to Architect and authorities having jurisdiction.

**1.6 Quality Assurance**

- 1.6.1 Installer Qualifications: Personnel shall be trained and certified by manufacturer for installation of units required for this Project. Experience minimum 5 years.
- 1.6.2 Installer Qualifications: Work of this Section shall be performed by a UL-listed company.
- 1.6.3 Installer Qualifications: Personnel certified by NICET as Fire Alarm Level II, III.
- 1.6.4 Electrical Components, Devices, and Accessories: Listed and labeled as defined in NFPA 70, Article 100, or BS EN 54 by a testing agency acceptable to authorities having jurisdiction, and marked for intended use.

**1.7 Guaranty Period Services**

- 1.7.1 All work performed and all material and equipment furnished under this contract shall be free from defects and shall remain so for a period of three years from the date of acceptance of the entire installation by the Engineer.
- 1.7.2 Complete inspection, testing, maintenance and repair service for the fire alarm system shall be provided by a factory trained authorized representative of the manufacturer of the major equipment for a period of 5 years from the date of acceptance of the entire installation by the Contracting Officer.
- 1.7.3 Contractor shall provide all necessary test equipment, parts and labor to perform required inspection, testing, maintenance and repair.
- 1.7.4 All inspection, testing, maintenance and permanent records required by NFPA 72, and recommended by the equipment manufacturer shall be provided by the contractor. Work shall include operation of sprinkler system alarm and supervisory devices. It shall include all interfaced equipment including but not limited to elevators, HVAC control, and extinguishing systems.
- 1.7.5 Maintenance and testing shall be performed in accordance with NFPA 72. A computerized preventive maintenance schedule shall be provided and shall describe the protocol for preventive maintenance of equipment. The schedule shall include a systematic examination, adjustment and cleaning of all equipment.

1.7.6 The contractor shall maintain a log at each fire alarm control unit. The log shall list the date and time of all examinations and trouble calls, condition of the system, and name of the technician. Each trouble call shall be fully described, including the nature of the trouble, necessary correction performed, and parts replaced.

1.7.7 In the event that Owner modifies the fire alarm system post-Acceptance but during the 5 years

Guaranty Period Service period, Contractor shall be required to verify that the system, as newly modified or added, is consistent with the manufacturer's requirements; any verification performed will be equitably adjusted under the Changes clause. The post-Acceptance modification or addition to the fire alarm system shall not void the continuing requirements under this contract set forth in the Guarantee Period Service provision for the fire alarm system as modified or added. The contract will be equitably adjusted under the Changes clause for such additional performance.

## **1.8 System Programming**

1.8.1 Fire Alarm Contractor is responsible for all system programming and testing of all devices wiring and panels.

1.8.2 Provide in final submittal both hard copy and electronic copy of final as-built FACP program and any documentation to clarify programming.

## **1.9 Extra Materials**

1.9.3 Furnish extra materials described below that match products installed and that are packaged with protective covering for storage and identified with labels describing contents.

1.9.3.1 Lamps for Remote Indicating lamps: Quantity equal to 2 percent of amount installed, but not less than 1 unit.

1.9.3.2 Lamps for strobe units: Quantity equal to 2 percent of amount installed, but not less than 1 unit.

1.9.3.3 Smoke, Heat, Combined and Flame Detectors: Quantity equal to 10 percent of amount of each type installed, but not less than 1 unit of each type.

1.9.3.4 Detector Bases: Quantity equal to 2 percent of amount of each type installed, but not less than 1 unit of each type.

1.9.3.5 Fire fighter's Telephone unit: Quantity equal to 2 percent of amount installed, but not less than 1 unit.

1.9.3.6 Keys and Tools: One extra set for access to locked and tamper-proofed components.

1.9.3.7 Audible and Visual Notification Appliances: One of each type installed.

1.9.3.8 Fuses: Two of each type installed in the system.

## **PART 2 PRODUCTS**

## **2.1 Fire Alarm System**

- 2.1.1 Fire alarm system shall provide early detection, accurate location of zone and point of origin of fire and automatic control of the ventilation and air conditioning system.
- 2.1.2 The fire alarm system shall provide visual and audible warning on main annunciator panel for supervisory signals such as:
  - 2.1.2.1 Failure or disconnection of power supply to main control panel
  - 2.1.2.2 Failure of fuse or protective device.
  - 2.1.2.3 Removal of detector head on any initiating circuit.
  - 2.1.2.4 Break or short circuit in wiring of any initiating or alarm circuit.
  - 2.1.2.5 Valve tamper at fire pumps.
  - 2.1.2.6 Fire pumps running.
  - 2.1.2.7 Fire pumps power loss.
  - 2.1.2.8 Fire pumps phase reversal.
- 2.1.3 Priority of signals: Automatic alarm response functions resulting from an alarm signal from one zone or device are not altered by subsequent alarm, supervisory or trouble signals. An alarm signal is the highest priority. Supervisory and trouble signals have 2nd and 3rd level priority.
- 2.1.4 System reset: all zones are manually resettable from the MFAC after initiating devices are restored to normal.
- 2.1.5 Transmission remote alarm receiving station: automatically route alarm, supervisory and trouble signals to a remote alarm station by means of a digital alarm communicator transmitter and telephone lines.
- 2.1.6 The Fire Command Center (FCC) shall function as listen to the point where all the operational and administration functions required for the systems provided within the specification. The FCC shall contain a console that will display and house any equipment necessary for system operation. Equipment included in the FCC shall include the following in accordance with NFPA 101:
  - 2.1.6.1 Main fire detection and fire alarm system Annunciation panel (MFACP).
  - 2.1.6.2 Emergency generators status indicators.
  - 2.1.6.3 Fire pump status indicators (LED).
  - 2.1.6.4 Sprinkler valves and water flow standard LED annunciator panel.
  - 2.1.6.5 Elevator floor location and operation annunciators using LED indicators that shall display elevator recall status.
  - 2.1.6.6 Voice fire alarm system panels and controls.
  - 2.1.6.7 Fire Department two-way telephone communication service panels and controls.



2.1.6.8 A telephone for fire department use with controlled access to the public telephone system.

## **2.2 MFACP**

2.2.1 General Description:

2.2.1.1 Modular, power-limited design with electronic modules, UL 864 listed.

2.2.1.2 Minimum Capacity: 6000 devices.

2.2.1.3 Addressable initiation devices that communicate device identity and status.

2.2.1.3.1 Smoke sensors shall additionally communicate sensitivity setting and allow for adjustment of sensitivity at the FACP.

2.2.1.3.2 Temperature sensors shall additionally test for and communicate the sensitivity range of the device.

2.2.1.4 Addressable control circuits for operation of mechanical equipment.

2.2.2 Alphanumeric Display and System Controls: Arranged for interface between human operator at the FACP and addressable system components including annunciation and supervision. Display alarm, supervisory, and component status messages and the programming and control menu. Refer to paragraph 2.4 "USER INTERFACE".

2.2.3 Circuits:

2.2.3.1 Initiating Device Circuits (IDC): NFPA 72, Class A, Style D or E.

2.2.3.2 Signaling Line Circuits (SLC): NFPA 72, Class A, Style 7.

2.2.3.3 Notification-Appliance Circuits (NAC): NFPA 72, Class A, Style Z.

2.2.3.4 Electrical monitoring for the integrity of wiring external to the FACP for mechanical equipment shutdown and magnetic door-holding circuits is not required, provided a break in the circuit will cause doors to close and mechanical equipment to shut down.

2.2.4 Smoke-Alarm Verification:

2.2.4.1 Initiate audible and visible indication of an "alarm verification" signal at the FACP.

2.2.4.2 Activate a listed and approved "alarm verification" sequence at the FACP and the detector.

2.2.4.3 Record events by the system printer.

2.2.4.4 Sound general alarm or alarm in fire zone if the fire is verified.

2.2.4.5 Cancel FACP indication and system reset if the alarm is not verified.

2.2.5 Notification-Appliance Circuit: Operation shall sound in a temporal pattern, complying with ANSI S3.41, 60 beats per minute, march-time pattern.

2.2.6 Elevator Controls: Heat detector operation in hoistway shuts down elevator power by operating a shunt trip in a circuit breaker feeding the elevator. Elevator

Controls: Water-flow alarm connected to sprinkler in an elevator shaft and elevator machine room shuts down elevators associated with the location without time delay. Elevator lobby smoke detector shall initiate elevator recall.

- 2.2.6.1 A field-mounted relay actuated by the fire detector or the FACP closes the shunt trip circuit and operates building notification appliances and annunciator.
- 2.2.7 Power Supply for Supervision Equipment: Supply for audible and visual equipment for supervision of the ac power shall be from a dedicated dc power supply, and power for the dc component shall be from the ac supply.
- 2.2.8 Alarm Silencing, Trouble, and Supervisory Alarm Reset: Manual reset at the FACP after initiating devices are restored to normal.
  - 2.2.8.1 Silencing-switch operation halts alarm operation of notification appliances and activates an "alarm silence" light. Display of identity of the alarm zone or device is retained.
  - 2.2.8.2 Subsequent alarm signals from other devices or zones reactivate notification appliances until silencing switch is operated again.
  - 2.2.8.3 When alarm-initiating devices return to normal and system reset switch is operated, notification appliances operate again until alarm silence switch is reset.
- 2.2.9 Walk Test: A test mode to allow one person to test alarm and supervisory features of initiating devices. Enabling of this mode shall require the entry of a password. The FACP and annunciators shall display a test indication while the test is underway. If testing ceases while in walk-test mode, after a preset delay, the system shall automatically return to normal.
- 2.2.10 Remote Smoke-Detector Sensitivity Adjustment: Controls shall select specific addressable smoke detectors for adjustment, display their current status and sensitivity settings, and control of changes in those settings. Allow controls to be used to program repetitive, time-scheduled, and automated changes in sensitivity of specific detector groups. Record sensitivity adjustments and sensitivity-adjustment schedule changes in system memory, and make a printout of the final adjusted values on the system printer.
- 2.2.11 Transmission to Remote Alarm Receiving Station: Automatically transmit alarm, trouble, and supervisory signals to a remote alarm station through a digital alarm communicator transmitter and telephone lines.
- 2.2.12 Service Modem: Ports shall be RS-232 for system printer and for connection to a dial-in terminal unit.
  - 2.2.12.1 The dial-in port shall allow remote access to the FACP for programming changes and system diagnostic routines. Access by a remote terminal shall be by encrypted password algorithm.
- 2.2.13 Printout of Events: On receipt of signal, print alarm, supervisory, and trouble events. Identify zone, device, and function. Include type of signal (alarm, supervisory, or trouble), and date and time of occurrence. Differentiate alarm signals from all other printed indications. Also print system reset event, including the same information for device, location,

date, and time. Commands initiate the printing of a list of existing alarm, supervisory, and trouble conditions in the system and a historical log of events.

2.2.14 Primary Power: 24-V dc obtained from 230-V ac service and a power-supply module.

Initiating devices, notification appliances, signaling lines, trouble signal, supervisory and digital alarm communicator transmitter shall be powered by the 24-V dc source.

2.2.14.1 The alarm current draw of the entire fire alarm system shall not exceed 80 percent of the power-supply module rating.

2.2.14.2 Power supply shall have a dedicated safety switch for this connection at the building service distribution panel. Paint the switch box red and identify it with "FIRE ALARM SYSTEM POWER."

2.2.15 Secondary Power: 24-V dc supply system with batteries and automatic battery charger and an automatic transfer switch.

2.2.16 Batteries shall be provided and shall be the dry sealed lead-acid type. The batteries shall have ample capacity with primary power disconnected to operate the fire alarm system for a period of 48 hours. Following this period of operation via batteries, the batteries shall have ample capacity to operate all components of the system, including all alarm signaling devices in the total alarm mode for a minimum period of 30 minutes.

2.2.17 Surge Protection:

2.2.17.1 Install surge protection on normal ac power for the FACP and its accessories.

2.2.17.2 Surge protectors shall be as recommended by FACP manufacturer.

2.2.18 Instructions: Computer printout or typewritten instruction card mounted behind a plastic or glass cover in a stainless-steel or aluminum frame. Include interpretation and describe appropriate response for displays and signals. Briefly describe the functional operation of the system under normal, alarm, and trouble conditions.

## **2.3 User Interface**

2.3.1 Panel LCD and Common Controls

2.3.1.1 The system shall be designed and equipped to receive, monitor, and annunciate signals from devices and circuits installed throughout the project.

2.3.1.2 Each fire alarm control panel (system node) shall be capable of supporting a backlit LCD display. The display on each system node shall be configurable to display the status of any and/or all combinations of all alarm, supervisory, trouble, monitor, or service group event messages on the network. Each LCD display on the system shall be capable of being programmed to allow control functions of any combination of nodes on the entire network. The system shall support both 168 character and 960-character LCD displays on the same network.

- 2.3.1.3 The LCD display shall provide separate alarm, trouble, supervisory, and monitor event queues of to minimize operator confusion. Receipt of alarm, trouble, and supervisory signals shall activate integral audible devices at the control panel(s) and at each remote annunciation device. The integral audible devices shall produce a sound output upon activation of not less than 85 dBA at 10 feet.
- 2.3.1.4 The LCD display shall contain the following system status indicators:
  - 2.3.1.4.1 System Power Indicator
  - 2.3.1.4.2 System Test Indicator
  - 2.3.1.4.3 System CPU Fail Indicator
  - 2.3.1.4.4 Ground Fault Indicator
  - 2.3.1.4.5 Disabled Points Indicator
  - 2.3.1.4.6 System Normal Indicator
  - 2.3.1.4.7 System Common Alarm Indicator
  - 2.3.1.4.8 System Common Trouble Indicator
  - 2.3.1.4.9 System Common Supervisory Indicator
  - 2.3.1.4.10 System Common Monitor Event Indicator
- 2.3.1.5 The LCD display shall contain the following system switch/indicators:
  - 2.3.1.5.1 System Reset Switch with Indicator
  - 2.3.1.5.2 System Alarm Silence Switch with Indicator
  - 2.3.1.5.3 System Panel Silence Switch with Indicator
  - 2.3.1.5.4 Drill Switch with Indicator
  - 2.3.1.5.5 Alarm Acknowledge Switch with Indicator
  - 2.3.1.5.6 Trouble Acknowledge Switch with Indicator
  - 2.3.1.5.7 Supervisory Acknowledge Switch with Indicator
  - 2.3.1.5.8 Monitor Acknowledge Switch with Indicator
- 2.3.1.6 The LCD display shall contain the following system function switches
  - 2.3.1.6.1 System Event Message Queue Scroll Switch.
  - 2.3.1.6.2 Event Details Switch (provides an additional 2000-character message about the device highlighted by the operator.)
  - 2.3.1.6.3 Command Menu Switch
  - 2.3.1.6.4 10-Digit Keypad with Enter and Backspace switches (Arranged to permit entry and execution of programming, display, and control commands; and to indicate control commands to be entered into the system for control of smoke-detector sensitivity and other parameters).
- 2.3.2 The user interface shall provide a backlit LCD that will allow custom event messages of up to 42 characters. The interface shall provide a minimum of eight lines by 21 characters and provide the emergency user hands free viewing of the first and last highest priority events. The last highest priority event shall always display and up- date automatically. Events shall be automatically placed in one of four easy to access queues. It shall be possible to scroll through and view specific alarm, trouble, supervisory and monitor events separately. Having to scroll through a mixed list of event types shall not be considered as equal. The total number of active and disabled events by type shall be displayed. Visual indication shall be provided of any event type that has not been acknowledged or viewed. It shall be possible to customize the designation of all user interface LEDs and Switches for local language requirements.

2.3.3 Instructional text messages shall support a maximum of 2,000 characters each.

## **2.4 Local Printer**

2.4.1 Printer shall provide hard-copy printout of all changes in status of the system and time-stamp such printouts with the current time-of-day and date. Printer shall be standard carriage with 80-characters per line and use standard pin-feed paper. Enclose printer in a separate cabinet suitable for placement on a desktop or table. Communication with the control panel shall utilize an interface complying with Electrical Industries Association standard EIA-232D. Power to the printer shall be  
230 VAC @ 50Hz.

2.4.2 System shall have a strip printer capable of being mounted directly in the main FACP enclosure. Alarms shall be printed in red, other messages, such as a trouble, shall be printed in black. Printer shall receive power from the system power supply and operate via battery back-up if AC mains are lost. Strip printer shall be UL 864 listed.

## **2.5 Enclosure of All Control Panels**

2.5.1 Control panel shall be housed in an UL-listed cabinet suitable for surface or semi-flush mounting. Cabinet and front shall be corrosion protected, given a rust-resistant prime coat, and manufacturer's standard finish.

2.5.2 Back box and door shall be constructed of 0.060 steel with provisions for electrical conduit connections into the sides and top.

2.5.3 Door shall provide a key lock and include a glass or other transparent opening for viewing indicators. Door may be site configured for either right or left hand hinging.

## **2.6 POWER SUPPLY:**

2.6.1 Power supply shall continuously monitor all field wires for earth ground conditions, and have the following LED indicators:

2.6.1.1 Ground Fault LED

2.6.1.2 AC Power Fail LED

2.6.1.3 NAC on LED (4)

2.6.1.4 Main power supply shall operate on 230 VAC, 50 Hz, and provide necessary power for the FACP.

Circuits shall be power-limited, per UL864 requirements.

## **2.7 Batteries**

2.7.1 The battery shall have sufficient capacity to power the fire alarm system for not less than forty-eight hours plus 30 minutes of full alarm upon a normal AC power failure.

- 2.7.2 The batteries are to be completely maintenance free. No liquids are required. Fluid level checks for refilling, spills, and leakage shall not be required.
- 2.7.3 If necessary to meet standby requirements, external battery and charger systems may be used if they are UL Listed with the system.
- 2.7.4 The system shall provide a means of monitoring the battery voltages from the front panel display for the local batteries.

## **2.8 Surge Suppression Devices**

- 2.8.1 The system shall utilize the following electrical surge protection devices to prevent damage and nuisance alarms caused by nearby lightning strikes, stray currents, or voltage transients.
- 2.8.2 On the AC Input of all fire alarm panels, remote power supplies and HPSA sites: Transvector ACO100BWN3, Leviton OEM-120EFI, EFI HWM-120, Ditek DTK-120HW or DTK-120/240 CM. AC Surge protectors shall be installed at the electrical panel board feeding the fire alarm equipment. Excess lead length shall be trimmed. The branch circuit conductor shall be formed into a 5-10 turn 1" diameter tie- wrapped coil just downstream of the suppressor connection.
- 2.8.3 On each DC fire alarm circuit entering or leaving the building: Transtector TSP8601, Citel American B280 -24V, Edco P264 and P642, Ditek DTKxLVL series, or equal.

## **2.9 Addressable Devices**

- 2.9.1 Addressable Devices - General
  - 2.9.1.1 Addressable devices shall use simple to install and maintain decade, decimal address switches.
  - 2.9.1.2 Addressable devices, which use a binary-coded address setting method, such as a DIP- switch, are not an allowable substitute due to increased risk of error and special knowledge required for maintenance.
  - 2.9.1.3 Detectors shall be intelligent and addressable, and shall connect with two wires to the fire alarm control panel Signaling Line Circuits.
  - 2.9.1.4 Addressable smoke and thermal detectors shall provide dual alarm and power/polling LEDs. LEDs shall flash green under normal conditions, indicating that the detector is operational and in regular communication with the control panel, and both LEDs shall be placed into steady red illumination by the control panel, indicating that an alarm condition has been detected. If required, the LED

flash shall have the ability to be removed from the system program. An output connection shall also be provided in the base to connect an external remote alarm LED.

- 2.9.1.5 The fire alarm control panel shall permit detector sensitivity adjustment through field programming of the system. The panel on a time-of-day basis shall automatically adjust sensitivity.
- 2.9.1.6 Using software in the FACP, detectors shall compensate for dust accumulation and other slow environmental changes that affect their performance. Detectors shall be listed by UL as meeting the calibrated sensitivity test requirements of NFPA Standard 72.
- 2.9.1.7 The detectors shall be ceiling-mount and shall include a separate twist-lock base with tamper proof feature. Bases shall include a sounder base with a built-in (local) sounder rated at 85 dBA minimum, a relay base and an isolator base designed for Style 7 applications.
- 2.9.1.8 The detectors shall provide a test means whereby they will simulate an alarm condition and report that condition to the control panel. Such a test may be initiated at the detector itself (by activating a magnetic switch) or initiated remotely on command from the control panel.
- 2.9.1.9 Detectors shall store an internal identifying type code that the control panel shall use to identify the type of device (photo, thermal).
- 2.9.1.10 Detectors will operate in an analog fashion, where the detector simply measures its designed environment variable and transmits an analog value to the FACP based on real-time measured values. FACP software, not the detector, shall make the alarm/normal decision, permitting the sensitivity of each detector to be set in the FACP program and allowing the system operator to view the current analog value of each detector.
- 2.9.1.11 A magnetic test switch shall be provided to test detectors and modules. Detectors shall report an indication of an analog value reaching 100% of the alarm threshold.
- 2.9.1.12 Addressable modules shall mount in a 4-inch square (101.6 mm square), 2-1/8 inch (54 mm) deep electrical box. An optional surface mount Lexan enclosure shall be available.
- 2.9.2 General Description:

- 2.9.2.1 UL 268 listed, operating at 24-V dc, nominal.
- 2.9.2.2 Integral Addressable Module: Arranged to communicate detector status (normal, alarm, or trouble) to the FACP.
- 2.9.2.3 Multipurpose type, containing the following:
  - 2.9.2.3.1 Integral Addressable Module: Arranged to communicate detector status (normal, alarm, or trouble) to the FACP.
  - 2.9.2.3.2 Piezoelectric sounder rated at 88 dBA at 10 feet (3 m) according to UL 464.
  - 2.9.2.3.3 Heat sensor, combination rate-of-rise and fixed temperature.
- 2.9.2.4 Plug-in Arrangement: Detector and associated electronic components shall be mounted in a plug-in module that connects to a fixed base. Provide terminals in the fixed base for connection of building wiring.
- 2.9.2.5 Self-Restoring: Detectors do not require resetting or readjustment after actuation to restore them to normal operation.
- 2.9.2.6 Integral Visual-Indicating Light: LED type. Indicating detector has operated and power-on status.
- 2.9.2.7 Remote Control: Unless otherwise indicated, detectors shall be analog-addressable type, individually monitored at the FACP for calibration, sensitivity, and alarm condition, and individually adjustable for sensitivity from the FACP.
  - 2.9.2.7.1 Rate-of-rise temperature characteristic shall be selectable at the FACP for (8 deg C) per minute.
  - 2.9.2.7.2 Fixed-temperature sensing shall be independent of rate-of-rise sensing and shall be settable at the FACP to operate at (57 deg C).
  - 2.9.2.7.3 Provide multiple levels of detection sensitivity for each sensor.

## **2.10 Addressable Manual Fire Alarm Box (Manual Station)**

- 2.10.1 Addressable manual fire alarm boxes shall, on command from control panel, send data to the panel representing the status of the manual switch and addressable communication module.
- 2.10.2 All operated stations shall have a positive, visual indication of operation and utilize a key type reset. They shall be designed so that after actual emergency operation, they cannot be restored to normal use except by the use of a key.
- 2.10.3 Manual fire alarm boxes shall be constructed of metal or plastic and finished in red with clearly visible operating instructions provided on the cover. The word FIRE shall appear on the front of the stations in raised letters, 1.75 inches (44 mm) or larger.
- 2.10.4 Double action mechanism requires two actions to initiate alarm non-break glass, lift cover and pull lever type.
- 2.10.5 Indoors protective shield: factory fabricated clear plastic enclosure hinged at the top to permit lifting for access to initiate an alarm. Lifting the cover actuates an



integral battery powered audible horn intended to discourage false alarm operation.

- 2.10.6 Weatherproof protective shield: factory fabricated clear plastic enclosure hinged at the top to permit lifting for access to initiate an alarm.

## **2.11 Intelligent Photoelectric Smoke Detector**

- 2.11.1 The detectors shall use the photoelectric (light-scattering) principal to measure smoke density and shall, on command from the control panel, send data to the panel representing the analog level of smoke density.

- 2.11.2 The intelligent photo smoke detector shall be a spot type detector that focuses the light beam to a very small volume near a receiving photo sensor. The scattering of smoke particles shall activate the photo sensor.

- 2.11.3 The detector shall have conductive plastic so that dust accumulation is reduced significantly.

- 2.11.4 The intelligent photo detector shall have nine sensitivity levels and be sensitive to a minimum obscuration of 0.03 percent per foot.

- 2.11.5 The intelligent photo detector shall support standard, relay, isolator and sounder detector bases.

- 2.11.6 Photo detector shall not require cleaning requirements other than those listed in NFPA 72. Replacement, refurbishment or specialized cleaning of the detector head shall not be required.

- 2.11.7 Photo detector shall include two bicolor LEDs that flash green in normal operation and turn on steady red in alarm.

## **2.12 Intelligent Multi Criteria Heat Smoke Detector**

- 2.12.1 Intelligent multi criteria Acclimate detector shall be an addressable device that is designed to monitor a minimum of photoelectric and thermal technologies in a single sensing device. Design shall include the ability to adapt by utilizing a built-in micro-processor to determine its environment and choose the appropriate sensing settings.

- 2.12.2 Detector design shall permit a sensitivity window, no less than 1 to 4% per foot obscuration.

- 2.12.3 Microprocessor design shall be capable of selecting the appropriate sensitivity levels based on the environment type it is in.

- 2.12.4 Intelligent multi criteria detection device shall include the ability to combine the signal of the thermal sensor with the signal of the photoelectric signal in an effort to react quickly in the event of a fire situation. It shall also include the inherent ability to distinguish between a fire condition and a false alarm condition by examining the characteristics of the thermal and smoke sensing chambers and comparing them to a database of actual fire and deceptive phenomena.

## **2.13 Intelligent thermal detectors:**

- 2.13.1 Thermal detectors shall be intelligent addressable devices rated at 135 degrees Fahrenheit (58 degrees Celsius) and have a rate-of-rise element rated at 15 degrees F (9.4 degrees C) per minute. It shall connect via two wires to the fire alarm control panel signaling line circuit.

## **2.14 Intelligent Duct Smoke Detector**

- 2.14.1 Smoke detector housing shall accommodate either an intelligent ionization detector or an intelligent photoelectric detector that provides continuous analog monitoring and alarm verification from the panel.

1. When sufficient smoke is sensed, an alarm signal is initiated at the FACP, and appropriate action taken to change over air handling systems to help prevent the rapid distribution of toxic smoke and fire gases throughout the areas served by the duct system.

## **2.15 Beam Type Smoke Detector**

- 2.15.1 Beam type smoke detectors shall be supplied at the locations shown on the drawings.

- 2.15.2 The beam smoke detector shall consist of a separate transmitter and receiver capable of being powered separately or together. The detector shall operate in either a short range of 30 to 100 ft. (9.14 to 30.4 m) or a long range of 100 to 300 ft. (30.4 to 91.4 m). The detector shall feature a bank of alignment LEDs on both the receiver and transmitter to ensure proper alignment without the use of special tools. The detector shall utilize an automatic gain control to compensate for gradual signal deterioration from dirt accumulation on lenses. The beam smoke detectors shall be powered from the system control panel. Testing shall be carried out using calibrated test filters.

- 2.15.3 Tamper switch: initiates trouble signal at the central MFAC when either transmitter or receiver is disturbed.

- 2.15.4 Separate color-coded LEDs: indicate normal, alarm and trouble status. Any detector trouble including power loss is reported to the central MFAC as a composite "trouble" signal.

## **2.16 Flame Detectors**

- 2.16.1 Ultraviolet type with solid-state amplifier-switching circuit set for 10-second delay, unless otherwise indicated.

- 2.16.1.1 Mounting: adaptor plate for outlet box mounting, plug-in base, interchangeable with smoke-detector bases.

2.16.1.2 Integral addressable module: Arranged to communicate detector status (normal, alarm, or trouble) to the FACP.

2.16.1.3 The control panel for the flame detection releasing system must be a microprocessor- based control capable of protecting multiple hazards in one control panel. It shall be U/L listed under standard 864 for Local Control Units for releasing service. The control must also be approved by FM and be compatible with the requirements of NFPA-13, NFPA-15, and NFPA-16.

2.16.1.4 The flame detector shall be a multi-spectral range detector consisting of either a UV and IR sensor or three IR sensors capable of detecting the radiation given off by a flame in the ultraviolet and / or infrared spectral ranges.

## **2.17 Modules**

### **2.17.1 General**

2.17.1.1 Intelligent addressable multifunction modules shall be provided at the locations shown on the drawings to provide the specific system input and output functions described by the operation section and functional matrix found elsewhere in this specification.

2.17.1.2 The operation of multifunction modules shall be software configurable at the site to meet operational conditions, and may be changed at any time by download changes from the control panel. The intelligent multifunction modules shall utilize electronic addressing. Modules using rotary or DIP switches, memory chips and / or jumpers for addressing shall not be considered as equal.

2.17.1.3 Each intelligent multifunction module on the Signaling Line Circuit (SLC) shall transmit information regarding its location with respect to other intelligent devices on the signaling line circuit to the control panel, creating an "As-Built" circuit map. The circuit mapping function shall provide location supervision of all intelligent de- vices on the signaling line circuit. An intelligent device's programmed system response functions shall be associated with the device's actual location on the signal- ing line circuit and not with the device's address. After system commissioning, de- vices improperly installed in the wrong location shall function according to the mapped programmed response for its location on the circuit, not its device address.

- 2.17.1.4 All input /output status decisions shall be made by the microprocessor within the module. Communications with a control panel shall not be required in order for the module to identify off-normal input/output conditions. Modules with supervised in- put or output circuits shall be capable of identifying ground fault conditions down to the module address level.
- 2.17.1.5 Each module shall be equipped with two (2) diagnostic indicators; a green LED to confirm communications and a red LED to display active status. LEDs shall be visible through the finished cover plate. The module shall be capable of storing a unique serial number and up to 24 diagnostic codes, hours of operation, number of alarms and troubles, and time of last alarm in its memory which can be retrieved for troubleshooting.
- 2.17.1.6 Where multiple modules are mounted in close proximity to each other, plug-in modular versions of the modules and motherboards shall be available to minimize field wiring and facilitate troubleshooting.
- 2.17.2 One Input Monitor
  - 2.17.2.1 Provide addressable single input multifunction modules at the locations shown on the drawings.
  - 2.17.2.2 Each module shall provide one (1) supervised Class B input circuit configurable as one of the following “personalities.”
    - 2.17.2.2.1 Normally-Open Alarm Latching (for alarm initiation applications)
    - 2.17.2.2.2 Normally-Open Alarm Delayed Latching (for waterflow switch applications)
    - 2.17.2.2.3 Normally-Open Active Non-Latching (for limit switch and monitor applications)
    - 2.17.2.2.4 Normally-Open Active Latching (for tamper switch and supervisory applications)
  - 2.17.2.3 Each module shall identify and report by device address, ground faults and opens associated with its initiating device circuit, to the control panel. Single function modules or without individual ground fault detection identification capability shall not be considered as equal.
- 2.17.3 Two Input Monitor
  - 2.17.3.1 Provide addressable dual input multifunction modules at the locations shown on the drawings.
  - 2.17.3.2 Each module shall provide two (2) supervised Class B input circuit configurable as one of the following “personalities.”
    - 2.17.3.2.1 Normally-Open Alarm Latching (for alarm initiation applications)
    - 2.17.3.2.2 Normally-Open Alarm Delayed Latching (for waterflow switch applications)
    - 2.17.3.2.3 Normally-Open Active Non-Latching (for limit switch and monitor applications)
    - 2.17.3.2.4 Normally-Open Active Latching (for tamper switch and supervisory applications)

- 2.17.3.3 Each module shall identify and report by device address, ground faults and opens associated with its initiating device circuits, to the control panel. Single function modules or without individual ground fault detection identification capability shall not be considered as equal.

## **2.18 Control Relay Module**

- 2.18.1 Control relay module shall provide four Form-C auxiliary relay circuits rated at 5 amperes, 28 VDC. An expansion circuit board shall allow expansion to eight Form-C relays per module.
- 2.18.2 Relay circuit shall be capable of being activated (change in state) by any initiating device or from any combination of initiating devices.
- 2.18.3 Provide relay module with 8 green ON/OFF LEDs and 8 yellow LEDs (indicates disabled status of the relay).
- 2.18.4 Provide a momentary switch per relay circuit that may be used to manually turn the relay ON/OFF or to disable the relay.
- 2.18.5 Relay circuit shall include a custom label inserted to identify its location. Labels shall be created using a standard typewriter or word processor.
- 2.18.6 Provide control relay module with removable wiring terminal blocks. Terminal blocks shall be UL listed for use with up to 12 AWG wire.

## **2.19 Addressable Dry Contact Monitor Module**

- 2.19.1 Addressable monitor modules shall be provided to connect one supervised IDC zone of conventional alarm initiating devices (any N.O. dry contact device) to one of the fire alarm control panels SLCs.
- 2.19.2 The IDC (Initiating Device Circuits) zone shall be suitable for Style D or Style B operation. LEDs shall be provided that shall flash under normal conditions, indicating that the monitor module is operational and in regular communication with the control panel.
- 2.19.3 For difficult to reach areas, the monitor module shall be available in a miniature package and shall be no larger than 2-3/4-inch (70 mm) x 1-1/4-inch (31.7 mm) x 1/2 inch (12.7 mm). This version need not include Style D or an LED.

## **2.20 Two Wire Detector Monitor Module**

- 2.20.1 Addressable monitor modules shall be provided to connect one supervised IDC zone of conventional 2-wire smoke detectors or alarm initiating devices (any N.O. dry contact device).
- 2.20.2 The IDC zone may be wired for Class A or B (Style D or Style B) operation. An LED shall be provided that shall flash under normal conditions, indicating that the monitor module is operational and in regular communication with the control panel.

## **2.21 Addressable Relay Module**

- 2.21.1 Addressable Relay Modules shall be available for HVAC control and other building functions. The relay shall be form C and rated for a minimum of 2.0 Amps resistive or 1.0 Amps inductive. The relay coil shall be magnetically latched to

reduce wiring connection requirements, and to ensure that 100% of all auxiliary relay or NACs may be energized at the same time on the same pair of wires.

## **2.22 Relay Base**

2.22.1 Provide relay detector bases suitable for mounting on North American 1-gang, 3½ or 4-inch octagon box and 4-inch square box, European BESA or 1-gang box; at the locations shown on the drawings.

2.22.2 The bases shall utilize a twist-lock design and provide screw terminals for all field wiring connections.

2.22.3 The base shall contain no electronics and support all Signature series detector types.

2.22.4 Removal of the respective detector shall not affect communications with other detectors.

2.22.5 The relay base shall meet the following requirements:

2.22.5.1 The relay shall be a bi-stable type and selectable for normally open or normally closed operation.

2.22.5.2 The position of the relay contact shall be supervised.

2.22.5.3 The operation of the base relay shall be configurable for control by its respective detector or for independent programmable control from the fire alarm panel. Relay bases not configurable for detector or panel operation shall not be considered equal.

2.22.5.4 The base relay shall provide form "C" contacts with a minimum rating of 1 amp @ 30

Vdc and be listed for pilot duty.

## **2.23 Isolator Module**

2.23.1 Isolator modules (one per maximum six elements) shall be provided to automatically isolate wire-to-wire short circuits on an SLC (Signaling Line Circuit) Class A or Class B branch. The isolator module shall limit the number of modules or detectors that may be rendered inoperative by a short circuit fault on the SLC loop segment or branch. At least one isolator module shall be provided for each floor or protected zone of the building.

2.23.2 If a wire-to-wire short occurs, the isolator module shall automatically open-circuit (disconnect) the SLC. When the short circuit condition is corrected, the isolator module shall reconnect the isolated section.

2.23.3 The isolator module shall not require address-setting, and its operations shall be totally automatic. It shall not be necessary to replace or reset an isolator module after its normal operation.

2.23.4 One isolator shall be provided for a maximum of six devices.

2.23.5 The isolator module shall provide a single LED that shall flash to indicate that the isolator is operational and shall illuminate steadily to indicate that a short circuit condition has been detected and isolated.

## **2.24 Strobes**

2.24.1 Strobes shall be wall or ceiling mounted as per drawings. The strobe light shall offer four field selectable candela strobe values 15/75, 30/75, 75 or 110 candelas. All set- ting shall be UL1971 listed for both wall and ceiling mount applications. The selector switch shall be tamper resistant. It shall not be necessary to remove the strobe from the mounting surface to select the strobe intensity.

2.24.2 The strobe shall produce a flash rate of one (1) flash per second with continuously applied voltage. The maximum pulse duration shall be 0.2 seconds with a maximum duty cycle of 40 percent. Rated voltage shall range from 18 to 31.2 volts for nominal

24-Vdc modules.

2.24.3 The strobe shall use Xenon flash tube with solid state circuitry for maximum reliability and efficiency. The Xenon flash tube and associated circuitry shall be enclosed in a translucent white polycarbonate lens with "fire" inscribed on the lens. Plate color shall be red. Operation shall be either sync or non-sync modes.

2.24.4 The strobes unit shall be standalone type or be incorporated as part of the (horn, bell) unit as per drawings and BOQ.

2.24.5 The lens construction shall provide high candela output with low current consumption while meeting UL and ADA standards.

## **2.25 Fire alarm bell:**

2.25.1 Technical specifications:

2.25.1.1 Operating voltage: 24Vdc

2.25.1.2 Operating Current: 0.060A

2.25.1.3 Operating temperature: -10°C to +50°C

2.25.1.4 Relative humidity: 95%

2.25.1.5 Sound Output: 100dB @1metre

2.25.1.6 Weatherproof for Outdoor.

2.25.1.7 Material and color: Stainless Steel; Red

2.25.1.8 Wiring: 1 pair polarized

2.25.1.9 Dimensions: Diameter 8 inches.

2.25.1.9.1 The sounder beacon should be installed in compliance with all local codes or NFPA 72

National Fire Alarm Code, NFPA 70 National Electrical Code, BS5389 and EN54. It shall be installed on to a standard one gang electrical box with a mounting hole that has 6.5cm spacing.

## **2.26 Fire fighter phone:**

- 2.26.1 It shall comply with Standard requirement for two-way telephone communication service.
- 2.26.2 The fire phone jack shall be mounted to a single gang stainless steel electrical plate. It shall have a break glass in front of the jack to eliminate tampering.
- 2.26.3 The fire telephones and phone jacks shall be provided with dry contacts which can be used for auxiliary functions.

## **2.27 Fire Fighter Phone Handset**

- 2.27.1 The fire fighter portable handset shall be constructed of high impact plastic. It shall be provided with a 180cm coiled cord with an audio jack connector. It shall have red color and shall be with flush door.

## **2.28 Wire and Cable**

- 2.28.1 All cables associated with Fire Alarm installation shall be of fire resistant (minimum 3 hours) 2 core 2.5sq.mm twisted pair. Cables shall comply with BS 6207 Part 1. The cable for use on the Fire Alarm loop shall be of the following type and specification. The cable is to BS 6207. Part 1 having, typically no more than 2 cores, A maximum of 190pF/m intercore capacitance, A maximum of 220 pF/m core to screen capacitance, A maximum of 18 ohms per core, Each core having 2.5 sq.mm cross sectional area. A read cover sheath (preferred for alarm applications), having continuous metal sheath encapsulation, Fire resistant tested to BS6387.

## **2.29 Signaling Line Circuit**

- 2.29.1 The signaling line circuit connecting panels/nodes to intelligent addressable devices including, detectors, monitor modules, control modules, isolation modules, intrusion detection modules and notification circuit modules shall be Class B (style 4). All signaling line circuits shall be supervised and power limited.
- 2.29.2 When the addressable devices on a signaling line circuit cover more than one designated fire/smoke compartment, a wire-to-wire short on the circuit shall not affect the operation of the addressable devices in other fire/smoke compartments.
- 2.29.3 Each SLC shall support 125 addressable detector addresses and 125 module addresses. The SLC shall support 100% of all addressable devices in alarm and provide support for a 100% compliment of detector isolator bases. Initial circuit loading shall not exceed 80% in order to allow for future system expansion.
- 2.29.4 T-taps (branching) shall be permitted on Class B circuits. Where possible, the devices installed at the end of each branch should be easily accessible for troubleshooting, e.g. a pull station at normal mounting height.



2.29.5 The addressable device SLC module shall be UL Listed for use with code compliant, electrically sound existing wiring.

2.29.6 Each intelligent addressable device shall transmit information about its location with respect to other devices on the circuit. This information shall be used to create an "As-Built" wiring diagram as well as provide enhanced supervision of a device's physical location. The device message and programmed system output function shall be associated with the device's location on the SLC circuit location and not a device address.

## **2.30 Signaling Circuit**

2.30.1 Fiber Optic Communications Interface

2.30.1.1 The electronics card shall plug right into the CPU. A ribbon cable connects the 3-CPU directly to the fiber interface card. The interface card mounts in the ½ footprint space in a chassis enclosure.

2.30.1.2 Standard Features:

2.30.1.2.1 Class A or Class B (Style 7 or Style 4) network data connections.

2.30.1.2.2 Class A or Class B (Style 7 or Style 4) audio data connections

2.30.1.2.3 Node to node distances:

2.30.1.2.4 multi-mode: up to 8000 ft. (2.4km) using multi-mode fiber.

2.30.1.2.5 Built-in test

2.30.1.2.6 Secondary power input

2.30.1.2.7 Transition from copper to fiber on same network

2.30.1.2.8 Transition from single to multi-mode fiber on same network

2.30.2 The RS-485 Network card shall give an CPU main board the ability to network through dedicated copper wire up to eight control panels. The card supports Class B and Class A wiring.

## **2.31 Satellite Fire Alarm Panels (FACP)**

2.31.1 All requirements specified in MFAC paragraph apply to the satellite fire alarm panels (FACP). FACP's are to be identical and compatible with the MFACP, capable of operating the system on a stand-alone basis. Each panel maintains the status and control of its own dedicated circuit points. But the satellites FACP's do not have any monitoring and controlling activity at other locations.

2.31.2 FACPs are to be independent local fire alarm control unit with local power supply and shall provide all power necessary for its own operation including standby power.

### **2.32 Remote Annunciator Panel (Farp)**

2.32.1 Duplicate annunciator functions of the MFACP for alarm, supervisory and trouble indications. Also, the duplicate manual switching functions of the MFACP including acknowledging, silencing, reset and test.

2.32.2 Mounting: surface cabinet.

2.32.3 Display type and functional performance: alphanumeric display same as the MFACP.

Controls with associated LEDs permit acknowledging, silencing resetting and testing functions for alarm, supervisory and trouble signals identical to those in the MFACP.

2.32.4 Graphic display panel for remote annunciator: wall-mounted engraved panel indicating the building floor plan.

2.32.5 Mounting: Adjacent to remote annunciator.

2.32.6 Materials: Satin finished stainless steel or brushed aluminum.

## **PART 3 EXECUTION**

### **3.1 Installation**

3.1.1 General

3.1.1.1 The entire system shall be installed in a skillful manner in accordance with approved manufacturer's installation manuals, shop drawings and wiring diagrams.

3.1.1.2 All work shall be performed in accordance with the requirements of NFPA 70 and

NFPA 72.

3.1.1.3 Coordinate locations of all devices with all other divisions' drawings and specifications.

3.1.1.4 All fire alarm devices shall be accessible for periodic maintenance. Should a device location indicated on the contract drawings not meet this requirement, it shall be the responsibility of the installing contractor to bring it, in writing, to the attention of the Project Engineer.

3.1.1.5 Fasten equipment to structural members of building or metal supports attached to structure, or to concrete surfaces.

3.1.1.6 All systems and system components listed to UL864 Control Units for Fire Protective Signaling Systems may be installed within a common conduit raceway system, in accordance with the manufacture's recommendations.

System(s) or system components not listed to the UL864 standard shall utilize a separate conduit raceway system for each of the sub-systems.

- 3.1.1.7 No wiring except life safety system circuits and system power supply circuits shall be permitted in the control panel enclosures.
- 3.1.1.8 Any low-voltage copper wiring that leaves the protection of a building shall be provided with a compatible UL 497B listed transient protection devices where the circuit leaves the building and where it enters the next building.
- 3.1.1.9 Devices containing end-of-line resistors shall be appropriately labeled. Devices should be labeled such that removal of the device is not required to identify the EOL device.
- 3.1.1.10 Fiber Optic Cable
  - 3.1.1.10.1 Only glass filament cable permitted. Plastic filament fiber optic cables are not acceptable.
  - 3.1.1.10.2 ST connectors shall be used at all equipment terminations.
- 3.1.1.11 Concrete floors shall be X-rayed prior to core drilling on post tension slabs. Verify with engineer on type of slab prior to bid.

## **3.2 Electrical**

### **3.2.1 Boxes, Enclosures and Wiring devices**

- 3.2.1.1 Boxes shall be installed plumb and firmly in position.
- 3.2.1.2 Extension rings with blank covers shall be installed on junction boxes where required.
- 3.2.1.3 Junction boxes served by concealed conduit shall be flush mounted.
- 3.2.1.4 Fire alarm system junction box covers shall be painted red.
- 3.2.1.5 Wiring within cabinets, enclosures, boxes, junction boxes and fittings shall be installed in a neat and workmanlike manner, installed parallel with or at right angles to the sides and back of any box, enclosure or cabinet, and routed to allow access for maintenance. All conductors that are terminated, spliced, or otherwise interrupted in any enclosure, cabinet, mounting or junction box shall be connected to terminal blocks. Mark each terminal in accordance with the wiring diagrams of the system. Make all connections with approved pressure type terminal blocks, which are securely mounted. All terminal block screws shall have pressure wire connectors of the self-lifting or box lug type. No more than two conductors shall be installed under one connection. Wire nuts, crimp splices and similar devices shall not be used.

### **3.2.2 Conductors**

- 3.2.2.1 Each conductor shall be identified as shown on the drawings at terminal points. Permanent wire markers shall be located within 2 inches of the wire termination. Marker text shall be visible with protective doors or covers removed.
- 3.2.2.2 Maintain a consistent color code for fire alarm system conductor functions throughout the installation.
- 3.2.2.3 All wiring shall be installed in compliance with the National Electric Code, NFPA 70, and the equipment manufacturer's requirements.
- 3.2.2.4 Wiring for Signaling Line Circuit and Initiating Device Circuit field wiring shall be solid copper, No. 18 AWG twisted pair conductors at a minimum. Speaker circuits; 16 AWG twisted pair at a minimum. Telephone circuits shall be 18 AWG twisted- shielded pair at a minimum. 24VDC visual and audible Notification Appliance Circuits shall be solid copper No. 14 AWG size conductors at a minimum. The wiring sizes listed herein are minimum sizes. Use larger wire sizes when recommended by the manufacturer, based on system configuration and project specific calculations.
- 3.2.2.5 Where shielded wiring is used, the shield shall be grounded at only one point, which shall be in or adjacent to the FACP or other control equipment. Shields shall be continuous, treated as a third conductor, and insulated from ground except as noted.
- 3.2.2.6 T-taps (branches) are permitted in Style 4 SLC circuits with interconnections occurring on terminal strips.
- 3.2.2.7 Circuits to third-party systems (HVAC, Elevators, fire pumps, etc.) shall terminate in terminal cabinets within three (3) feet of the controllers for those systems. AC power wiring shall be No. 12 AWG solid copper having insulation rated for 600 volts.
- 3.2.2.8 Crimp type spade lugs shall be used for terminations of stranded conductors to binder screws or stud type terminals.
- 3.2.2.9 All wiring shall be checked and tested to ensure that there are no grounds, opens or shorts.
- 3.2.3 Raceways
  - 3.2.3.1 Conduits shall be sized according to the conductors contained therein. Cross sectional area percentage fill for system conduits shall not exceed 40%.
  - 3.2.3.2 Install all conductors in rigid metal conduit or electro-metallic tubing, utilizing compression type fittings and couplings, with a minimum diameter 3/4". The use of flexible metal conduit not exceeding a six (6) foot length shall be permitted for initiating device circuits.

- 3.2.3.3 All fire alarm conduit systems shall be routed and installed to minimize the potential for physical, mechanical or fire damage, and shall not to interfere with existing building systems, facilities or equipment.
- 3.2.3.4 Run conduit or tubing concealed in finished areas unless specifically shown otherwise on the drawings. Conduit may be exposed in unfinished mechanical/electrical rooms, and basement levels.
- 3.2.3.5 All system conduits, junction boxes, pull boxes, terminal cabinets, electrical enclosures and device back box locations shall be readily accessible for inspection, testing, service and maintenance.
- 3.2.4 Open cable
  - 3.2.4.1 Power Limited cable, when not installed in UL listed metal conduit or raceway, shall be mechanically protected by building construction features par NFPA 70, Article 760.
    - 3.2.4.1.1 Installation shall be in areas not subjected to mechanical injury.
    - 3.2.4.1.2 All circuits shall be supported by the building structure. Cable shall be attached by straps or bridal rings to the building structure at intervals not greater than 10 feet. The use of staples is prohibited. Fire alarm wiring shall not be bundled or strapped to existing conduit, pipe or wire in the facility.
    - 3.2.4.1.3 Where wiring is installed above drop ceilings, cable shall not be laid on ceiling tiles.
    - 3.2.4.1.4 Cable shall not be fastened in a manner that puts tension on the cable.
  - 3.2.4.2 Power Limited Cable shall be FPLP, FPLR or FPL, or permitted substitute.
- 3.2.5 FA Components
  - 3.2.5.1 Devices
    - 3.2.5.1.1 All devices and appliances shall be mounted to or in an approved electrical box.
    - 3.2.5.1.2 All wall mounted *control equipment* shall comply with requirements defined by the International Building Code and Acceptance Criteria for Seismic Qualification by Shake-Table Testing of Nonstructural Components and Systems (AC-156) using a seismic component importance factor of 1.5.
  - 3.2.5.2 Fire Alarm Control Panels
    - 3.2.5.2.1 Mount the enclosure with the top of the cabinet 72" above the finished floor or center the cabinet at 63", whichever is lower.
    - 3.2.5.2.2 Label the fire alarm panels with the room number, electrical panel number and circuit breaker number feeding them.

- 3.2.5.2.3 Paint the handles of the dedicated circuit breakers feeding fire alarm panels red, and install handle locks.
- 3.2.5.2.4 Within the panel, all non-power limited wiring must be properly separated from power limited circuits.
- 3.2.5.2.5 Grounds shall comply with IEEE 1100. Install a ground wire from main service ground to fire-alarm control unit.
- 3.2.5.3 Graphic Remote Annunciator
  - 3.2.5.3.1 Mount the panel; with the top of the panel 72" above the finished floor or center the panel at 63", whichever is lower.
- 3.2.5.4 Remote power supplies and auxiliary fire alarm panels
  - 3.2.5.4.1 Locate the panel or cabinet with the top of the panel 72" above the finished floor or center the panel at 63", whichever is lower.
  - 3.2.5.4.2 Do not locate these panels above ceilings or where inaccessible by a person standing on the finished floor of the space.
  - 3.2.5.4.3 Label the power supplies and auxiliary FACPs with the room number, electrical panel number and circuit breaker number feeding them.
  - 3.2.5.4.4 Paint the handles of the dedicated circuit breakers feeding fire alarm panels red, and install handle locks.
  - 3.2.5.4.5 Within the panel, all non-power limited wiring must be properly separated from power limited circuits.
- 3.2.5.5 Manual Pull Stations
  - 3.2.5.5.1 Mount stations so that their operating handles are between 42" and 48" above the finished floor.
- 3.2.5.6 Firefighter Telephone Jacks
  - 3.2.5.6.1 Wall mounted at 48" above the finished floor.
- 3.2.5.7 Notification Appliances: Mount assemblies as follows:
  - 3.2.5.7.1 All wall mounted audio/visual devices shall be mounted so the entire lens is between 80" and 96" above the finished floor. Where low ceilings exist, devices shall be mounted within 6" of the ceiling.
  - 3.2.5.7.2 Each speaker's (horn) output shall be set to the wattage value indicated for its specific location as shown on the drawings.
  - 3.2.5.7.3 Each strobe's output shall be set to the candela value indicated for its specific location as shown on the drawings.
  - 3.2.5.7.4 Each speaker (horn)-strobe's outputs shall be set to the wattage/candela value indicated for its specific location as shown on the drawings.

- 3.2.5.7.5 Where ceiling height exceeds 30 feet, appliances shall be suspended from the ceiling to a height of 30 feet maximum above the finished floor.
- 3.2.5.7.6 Appliances installed outdoors shall be UL listed for outdoor use.
- 3.2.5.8 Smoke Detectors:
  - 3.2.5.8.1 Smoke and heat detector heads shall not be installed until after construction clean-up is completed. Detector heads installed prior to construction clean-up shall be cleaned by the manufacturer or replaced.
  - 3.2.5.8.2 Detectors located on the wall shall have the top of the detector at least 4" and not more than 12" below the ceiling.
  - 3.2.5.8.3 On smooth ceilings, detectors shall not be installed over 30 ft. apart in any direction.
  - 3.2.5.8.4 Install smoke detectors no closer than 3 ft. from air handling supply air diffusers or return air openings.
  - 3.2.5.8.5 Locate detectors no closer than 12" from any part of a lighting fixture.
- 3.2.5.9 Duct Smoke Detectors:
  - 3.2.5.9.1 Install sampling tubes so they extend the full width of ducts exceeding 36".
  - 3.2.5.9.2 Detectors shall be located to facilitate ease of maintenance.
  - 3.2.5.9.3 All penetrations near detectors located on/in return ducts shall be sealed to prevent air entry.
- 3.2.5.10 End-of-Line Resistors
  - 3.2.5.10.1 Devices containing end-of-line resistors shall be appropriately labeled.
- 3.2.5.11 Remote Status and Alarm Indicators:
  - a. Install near each smoke detector and each sprinkler water-flow switch and valve- tamper switch that is not readily visible from normal viewing position.
- 3.2.5.12 CO Detectors
  - 3.2.5.12.1 Ceiling mounted CO detectors should be kept 12" from sidewalls.
  - 3.2.5.12.2 Wall mounted CO detectors should be at least 48" above the finished floor, but less than 6" from the ceiling.
  - 3.2.5.12.3 Locate at least 60" from fuel burning appliances.
  - 3.2.5.12.4 Install CO detectors no closer than 3 ft. from air handling supply air diffusers or return air openings.
- 3.2.5.13 Beam Smoke Detectors

3.2.5.13.1 Install beam type smoke detectors in accordance with the shop drawings and the manufacturer's recommendations.

3.2.5.13.2 Mount detectors 19" to 24" below the ceiling unless instructed otherwise.

3.2.5.13.3 Keep the centerline of the beam 19" from obstructions.

3.2.5.13.4 Mount on solid surfaces (brick/block walls, steel beams, or concrete).

3.2.5.13.5 Use all mounting points on detector mounts.

3.2.5.13.6 Mount where accessible for maintenance.

#### 3.2.5.14 Heat Detectors

3.2.5.14.1 Heat detectors shall be installed in strict accordance with their UL listing and the requirements of NFPA 72.

3.2.5.14.2 Heat detectors installed in the elevator machinery room to meet ANSI A17.1 requirements for elevator power disconnect, shall be located adjacent to each sprinkler head. Coordinate temperature rating and location with sprinkler rating and location.

#### 3.2.5.15 Addressable Control (relay) Modules

3.2.5.15.1 Install the module less than 3 feet from the device controlled.

3.2.5.15.2 Orient the device mounting for best maintenance access.

3.2.5.15.3 Label all addressable control modules as to their function.

3.2.5.15.4 Provide a dedicated 24VDC circuit to feed all auxiliary relays required for inductive loads (auxiliary relays, door holders). Circuits shall be supervised via an end-of-line relay and addressable input module. Auxiliary relays shall not derive their power from the starter or load being controlled.

### **END OF SECTION**

## ***SECTION 20000- OFF-GRID SOLAR PV SYSTEMS***

### **1. Scope of the Work**

1.1. The scope includes guidelines and practices for the Supply, Installation, Testing and Commissioning of Off- Grid rooftop/Ground Mounted PV power plants.

1.2. Feasibility study, necessary civil work, Mounting of Module Structures, PV Module Installation, Inverter Installation, DC/AC Cabling and interconnections, Installation of Lightning Arresters and Earthing System as per the standards, Testing of PV Power Plant and Commissioning under engineer supervision.



## 2. Location

2.1. Shade-free Rooftops of Residential, Public/Private Commercial/Industrial buildings, Local Self Government Buildings, State Government buildings.

## 3. Definition

3.1. Standalone solar PV power plant comprises of C-Si (Crystalline Silicon)/Thin Film Solar PV modules with intelligent Inverter with MPPT charging technology which feeds uninterrupted quality AC power to electrical loads. Batteries will be charged from solar energy by charge controller integrated in the inverter or by an external charge controller with MPPT technology. Other than PV Modules and Inverter/Inverters, the system consists of Module Mounting Structures, appropriate DC and AC Cables, Array Junction Boxes (AJB) / String Combiner Boxes (SCB), AC and DC Distribution Box, Vertical DB for Load segregation, Lightning Arrester, Earthing Systems, etc.

## 4. Solar PV Module

4.1. The PV modules must be PID compliant, salt, mist & ammonia resistant and should withstand weather conditions for the project life cycle.

4.2. The back sheet of PV module shall be minimum of three layers with outer layer (exposure to ambience) and shall be made of PVDF or PVF. The Back sheets for PV Module with 2 layered or 3 layered Polyester types or the back sheets with Polyester (PET type) at Air side material are not permitted for the empanelment; The minimum thickness of the core layers (without adhesive and inner EVA coated) must be 300 microns. The maximum allowed water vapor transmission rate shall be less than 2 g / m<sup>2</sup>/day and shall have a Partial Discharge > / = 1500V DC

The front glass shall meet the following specifications:

- a. The facing glass must be Tempered, PV grade with Low iron and high transmission.
- b. The transmission shall be > 93 %
- c. Thickness shall be min 3.2 mm
- d. Textured to trap more light
- e. The glass shall have an Anti-reflective coating for the better transmission and light absorption.
- f. Tempered glass to meet the external load conditions

4.4. The encapsulant used for the PV modules should be UV resistant in nature. No yellowing of the encapsulant with prolonged exposure shall occur. The sealant used for edge sealing of PV modules shall have excellent moisture ingress Protection with good electrical insulation and with good adhesion strength. Edge tapes for sealing are not allowed.

4.5. Anodized Aluminium module frames of sufficient thickness shall be used which are electrically & chemically compatible with the structural material used for mounting the modules having provision for earthing.

4.6. UV resistant junction boxes with minimum three numbers of bypass diodes and two numbers of MC4 connectors or equivalent with appropriate length of 4 sq.mm Cu cable shall be provided. IP67 degree of protection shall be used to avoid degradation during Life.

4.7. Shading correction/ bypass diode for optimizing PV out to be incorporated in each solar module or panel level.

4.8. Each PV module used in any solar power project must use a RF identification tag (RFID), which must contain the following information. The RFID can be inside or outside the module laminate but must be able to withstand harsh environmental conditions.

- a. Name of the manufacturer of PV Module.
- b. Name of the manufacturer of Solar cells.
- c. Month and year of the manufacture (separately for solar cells and module).
- d. Country of origin (separately for solar cell and module).
- e. I-V curve for the module.
- f. Peak Wattage, IM, VM and FF for the module.
- g. Unique Serial No. and Model No. of the module.
- h. Date and year of obtaining IEC PV module qualification certificate.
- i. Name of the test lab issuing IEC certificate.

4.9. Other relevant information on traceability of solar cells and module as per ISO 9000 series.

- a. The following details should be provided on the module
- b. Name of the manufacture.
- c. Month and year of manufacture.
- d. Rated Power at STC.
- e. VMP, IMP, VOC, Isc.

4.10. The successful bidder shall arrange an RFID reader to show the RFID details of the modules transported to sites, to the site Engineer in charge up to their satisfaction, which is mandatory for the site acceptance test.

4.11. Each PV module used in any solar power project must use a RF identification tag (RFID), which must contain the following information. The RFID can be inside or outside the module laminate but must be able to withstand harsh environmental conditions.

4.12. The PV modules must qualify (enclose Test Reports/Certificates from accredited laboratory) as per relevant IEC standard. The Performance of PV Modules at STC conditions must be tested and approved by one of the IEC/NABL Accredited Testing Laboratories.

4.13. PV modules used in solar power plant/ systems must be warranted for 10 years for their material, manufacturing defects, workmanship. The output peak watt capacity which should not be less than 90% at the end of 10 years and 80% at the end of 25 years

4.14. Original Equipment Manufacturers (OEM) Warrantee of the PV Modules shall be submitted by the successful bidder when the materials delivered at site.

4.15. The PV Module should be under Indigenous / DCR (Domestic Content Requirement) category (Based on the specific requirement).

4.16. The PV modules shall conform to the following standards:

- a. IS 14286: Crystalline silicon terrestrial photovoltaic (PV) modules — design qualification and type approval.
- b. IEC 61215 / IEC 61646: c-Si (IEC 61215): Crystalline silicon terrestrial photovoltaic (PV) modules – Design qualification and type approval Thin Film (IEC 61646): Design, Qualification & Type Approval

- c. IEC 61730-1: Photovoltaic Module safety qualification- Part 1: Requirements for construction
- d. IEC 61730-2: Photovoltaic Module safety qualification- Part 2: Requirements for testing
- e. IEC 61701: Salt mist corrosion testing of photovoltaic modules
- f. IEC 62716: Test Sequences useful to determine the resistance of PV Modules to

Ammonia (NH<sub>3</sub>)

4.17. The PV module should have IS14286 qualification certification for solar PV modules (Crystalline silicon terrestrial photovoltaic (PV) modules — design qualification and type approval).

4.18. PV Module of same Make/ Model in the same series shall be considered as a single product while making the payment.

## 5. POWER CONDITIONING UNIT

Power Conditioning Unit (inverter) comprises of charge controller with MPPT technology that is either integrated with the inverter or as a separate unit. The EPC Company/ Contractor shall use only the OFF-Grid inverters that are from verified manufacturer. The specifications for the OFF-Grid inverter are detailed below:

### 5.1. General Specifications:

All the Inverters should contain the following clear and indelible Marking Label & Warning Label as per IS16221 Part II, clause 5. The equipment shall, as a minimum, be permanently marked with:

- i. The name or trademark of the manufacturer or supplier.
- ii. A model number, name or other means to identify the equipment.
- iii. A serial number, code or other markings allowing identification of manufacturing location and the manufacturing batch or date within a three-month time period.
- iv. Input voltage, type of voltage (A.C. or D.C.), frequency, and maximum continuous current for each input.
- v. Output voltage, type of voltage (A.C. or D.C.), frequency, maximum continuous current, and for A.C. outputs, either the power or power factor for each output.
- vi. The Ingress Protection (IP) rating

5.2. Off- Grid Inverters from 1kW/1kVA to 50kW/50kVA will be empanelled.

5.3. The control system should continuously adjust the voltage of the generator to optimize the power available. The power conditioner must automatically re-enter standby mode when input power reduces below the standby mode threshold. Front Panel display should provide the status and fault indication (if any)

5.4. The inverter should have IGBT/MOSFET based controlling elements and current regulated systems

5.5. Operational Voltage Range: Suitable System Voltage according to the battery bank and panel array

5.6. The inverter must have MPPT power electronics for the maximum extraction of PV power

5.7. The inverter shall provide electronic protection against the following type of faults:

- a. Overload
- b. Over temperature
- c. Reverse polarity
- d. Short circuit (circuit breaker & electronic protection against sustained fault).
- e. Over-load protection.
- f. Under voltage & Over-voltage of Battery.
- g. Auto/ Manual re-connects provision.
- h. Reverse polarity protection both for the PV array and Battery bank (DC)

5.8. Auto resetting electronic over current protection

5.9. The inverter must have a RS485/RS232 interface

5.10. The inverter shall conform to IEC 61683/ IS 61683 for efficiency measurement, and IEC 60068-2 (1,2,14,30) or equivalent BIS standard for environmental testing.

5.11. Operational Voltage Range: Suitable System Voltage according to the battery bank and panel array

5.12. Type: Self commuted, current regulated, IGBT/ MOSFET based.

5.13. Output voltage: Output voltage 230V/415V

5.14. Output frequency :50 Hz

5.15. THD: Less than (<) 5%

5.16. Efficiency: 90% or above at full load.

5.17. Ambient temperature: 5 to 55°C

5.18. Protections:

- a. Short circuit (circuit breaker & electronic protection against sustained fault)
- b. Over-load protection
- c. Under voltage & Over-voltage of Battery
- d. Auto/Manual re-connect provision
- e. Reverse polarity protection both for the PV array and Battery bank (DC)
- f. Ingress Protections: IP20/ IP 21 or above

5.19. Other Features:

a. Surge Protection: 150% of the rated capacity for a period of 10 seconds b. Acoustic Noise Level  $\leq$  50 dB

5.20. Recommended Indicators / Displays / Alarms

- a. Digital Display(s) of input DC SPV voltage & current, along with Energy Meter
- b. Digital Display (s) AC output voltage, frequency, power and current
- c. Digital Display of output AC kWh meter (Daily/ Cumulative)
- d. Overload Alarm / cut-off
- e. System Cut-off Indicator
- f. System Reset Button.
- g. Battery voltage and current.
- h. SPV charging.
- i. Battery Charge Level LED Indicator (s) – Low, Medium, High, Full.
- j. Battery Low indicator and Alarm/ cut-off.

## 6. BATTERY BANK

6.1. The battery bank can be LMLA, VRLA (Smf or Gel) or Lithium Ferro Phosphate. The EPC Company/ Contractor shall use only the Batteries that are verified manufacturer. However, the specifications for the Batteries are detailed below:

#### 6.2. Technical Requirements

No: Parameters

1. Nominal Capacity (Ah) shall be rated @C10
2. Minimum Nominal Cell voltage (V): 2V / Lithium ferro phosphate: 3.2V
- 3, Self-discharge (less than 3% per month at 30°C)
- 4 A 6-hour backup of requirement is estimated as 7200Wh

#### 6.3. General Specifications:

- a. Test certificate submitted should qualify the minimum requirements as per above standards for capacity test, ampere-hour efficiency test, watt-hour efficiency test, self- discharge test.
- b. Battery (Lead Acid LMLA/Lead Acid –VRLA or SMF/Lead Acid GEL) shall have a warrantee of minimum 5 years and Lithium Ferro Phosphate Battery shall have a warrantee of minimum 10years
- c. Battery capacity is rated C/10 at 27°C
- d. Original Equipment Manufacturers (OEM) Warrantee of Battery shall be submitted
- e. There should be a separate Battery Management System if the Lithium Ferro Phosphate Battery is used for the PV Power Plant.

#### 6.4. Standards and Certifications

Major IS/IEC Certification for LMLA/VRLA / Lithium Ferro Phosphate batteries are listed below:

<b>Standard</b>	<b>Description</b>
IEC 61427	IEC 61427 – This series gives general information relating to the requirements for the secondary batteries used in photovoltaic energy systems (PVES) and to the typical methods of test used for the verification of battery performances.  This part of IEC 60896 applies to all stationary lead-acid cells and
IEC 60896	Monobloc batteries of the valve regulated type for float charge applications, (i.e., permanently connected to a load and to a d.c. power supply), in a static location (i.e., not generally intended to be moved from place to place) and incorporated into stationary equipment or installed in battery rooms for use in telecom, uninterruptible power supply (UPS), utility switching, emergency power or similar applications.

IS 13369:1992	This standard specifies Ah capacities, voltage, overall dimensions, performance requirements and tests for stationary lead-acid units in Monobloc container.
IS 1651:2013	This standard specifies rated Ah capacities, overall dimensions, performance requirements and tests for Stationary Lead Acid Cells and Batteries using Tubular Positive Plates
IS 15549:2005	This standard specifies capacities and performance requirements and corresponding test methods for all types of high integrity series stationary Valve regulated lead acid batteries.
IS 16046: 2015 / IEC 62133:  2012**	Defines requirements and tests for the safe operation of portable sealed secondary cells and batteries containing alkaline or other non- acid electrolyte, under intended use and reasonably foreseeable misuse.
IEC 61056*	IEC 61056-1:2012 specifies the general requirements, functional characteristics and methods of test for all general-purpose lead-acid cells and batteries of the valve-regulated type
IS 16220*	IS 16220 defines the general requirements, functional characteristics and methods of test for all general-purpose lead- acid cells and batteries of the valve- regulated type.
IEC 62133-2: 2017**	IEC 62133 requirements and tests for the safe operation of portable sealed secondary lithium cells and batteries containing non-acid electrolyte, under intended use and reasonably foreseeable misuse.
IEC 62620:2014**	IEC 62620 defines marking, tests and requirements for lithium secondary cells and batteries used in industrial applications including stationary applications.

\* Recommended

\*\* Applies for Lithium Ferro phosphate batteries

## 7. MODULE MOUNTING STRUCTURE

- Photovoltaic arrays must be mounted on a stable, durable structure that can support the array and withstand wind, rain, and other adverse conditions. The modules will be fixed on structures with fixed arrangement.
- The module mounting structures shall have adequate strength and appropriate design suitable to the locations, which can withstand the load and high wind velocities. Stationary structures shall support PV modules at a given orientation, absorb and transfer the mechanical loads to the surface properly.
- Each structure with fixed tilt should have a tilt angle as per the site conditions to take maximum insolation which will be approximately equal to the latitude of the location facing true South with a North – South orientation. The tilt angle can vary from 9 degree to 12 degree based on the location's latitude in Kerala
- The PV module mounting structure shall have a capacity to withstand a wind velocity of 150 km/hr.
- Suitable fastening arrangement such as grouting and calming should be provided to secure the installation against the specific wind speed. The PV array structure design shall be appropriate with a factor of safety of min 1.5. The STAAD / Equivalent structural design report must be attached along with the technical bid.
- The materials used for structures shall be Hot dip Galvanized Mild Steel conformed to IS 2062:1992 or aluminium of suitable grade minimum alloy 6063 or better.
- The minimum thickness of galvanization for hot dip Galvanized Mild Steel should be at least 80 microns as per IS 4759.
- The Bolts, Nuts, fasteners, and clamps used for panel mounting shall be of Stainless-Steel SS 304.
- No Welding is allowed on the mounting structure
- Aluminium structures used shall be protected against rusting either by coating or anodization.
- Aluminium frames should be avoided for installations in coastal areas.
- The structure shall be designed to withstand operating environmental conditions for a period of minimum 25 years. And shall be free from corrosion while installation.
- Screw fasteners shall use existing mounting holes provided by module manufacturer. No additional holes shall be drilled on module frames
- The total load of the structure (when installed with PV modules) on the terrace should be less than 60 kg/m<sup>2</sup>.
- Minimum distance between the lower level of PV Module and the ground shall be 0.6m from the ground level.
- The PV Panel area shall be accessible for cleaning and for any repair work.
- Sufficient gap needs to be provided between the rows to avoid falling of shadow of one row on the next row. Seismic factors for the site will be considered while making the design of the foundation.
  - Adequate spacing shall be provided between any two modules secured on PV panel for improved wind resistance.
- Installation of structure for solar PV mounting should not tamper with the water proofing of the roofs.
- The above drawing is specific for RCC flat roofs and may vary for slope roofs. However, the drawings shall be approved by concerned Technical Officer before installing the plant

## **8. SOLAR METER and NETMETER**

## Solar Meter:

A separate Energy Meter called Solar Meter shall be provided at the output of PCU to record the energy generation from the Solar System. (This energy meter should not be integrated with PCU). Solar energy meter means a unidirectional meter to be installed at the delivery point of the solar energy system to measure the solar electricity generated.

The solar energy meters shall be provided with necessary ports like RS485 for communications.

## 9. EARTHING

The Solar PV Plant should have a dedicated earthing system. The Earthing for array and LT power shall be made as per the provisions of IS:3043-2018 “Code of practice for earthing (Second Revision),” that governs the earthing practices of a PV system and IS 732:2019 “Code of practice for electrical wiring installations (Fourth Revision)

9.1. Earthing System shall connect all non –current carrying metal receptacles, electrical boxes, appliance frames, chassis and PV module mounting structures in one long run. The earth strips should not be bolted. Earthing GI strips shall be interconnected by proper welding.

9.2. The earthing conductor should be rated for 1.56 times the maximum short circuit current of the PV array. The factor 1.56 considers 25 percent as a safety factor and 25 percent as albedo factor to protect from any unaccounted external reflection onto the PV modules increasing its current.

9.3. In any case, the cross-section area or the earthing conductor for PV equipment should not be less than 6 mm<sup>2</sup> if copper, 10 mm<sup>2</sup> if aluminium or 70 mm<sup>2</sup> if hot-dipped galvanized iron. For the earthing of lightning arrestor, cross-section of the earthing conductor should not be less than 16 mm<sup>2</sup> of copper or 70 mm<sup>2</sup> if hot-dipped galvanized iron. The complete Earthing system shall be mechanically & electrically connected to provide independent return to earth.

9.4. Masonry enclosure with the earth pit of size not less than 400mm X 400 mm(depth) complete with cemented brick work (1:6) of minimum 150mm width duly plastered with cement mortar (inside)shall be provided. Hinged inspection covers of size not less than 300mm X 300mm with locking arrangement shall be provided. Suitable handle shall be provided on the cover by means of welding a rod on top of the cover for future maintenance.

9.5. Minimum four (04) numbers of interconnected earth pit need to be provided in each location. Minimum required gap shall be provided in between earth pits as per relevant standard. Body earthing shall be provided in inverter, each panel frame, module mounting structure, kiosk and in any other item as required.

9.6. Earth pit shall be constructed as per IS: 3043-2018. Electrodes shall be embedded below permanent moisture level. Earth pits shall be treated with salt and charcoal if average resistance of soil is more than 20-ohm meter.



9.7. Earth resistance shall not be more than 5 ohms. Earthing system must be interconnected through GI strip to arrive equipotential bonding. The size of the GI earth strip must be minimum 25mm X 6mm.

9.8. In compliance to electricity codes, all non-current carrying metal parts shall be Earthing with two separate and distinct earth continuity conductors to an efficient earth electrode.

9.9. The equipment grounding wire shall be connected to earth strip by proper fixing arrangement. Each strip shall be continued up to at least 500mm from the equipment.

9.10. Necessary provisions shall be made for bolted isolating joints of each earthing pit for periodic checking of earth resistance.

9.11. For each earth pit, a necessary test point shall be provided.

9.12. Total no of Earth pits for solar plants: AC-01, DC-02, LA-01

9.1. The bidder shall submit the detailed specification and drawings for the Earthing arrangements.

## **10. LIGHTNING PROTECTION**

The SPV power plant should be provided with lightning and over voltage protection. The source of over voltage can be lightning or other atmospheric disturbance. The lightning conductors shall be made as per applicable international Standards in order to protect the entire array yard from lightning stroke.

The design and specification shall conform to IS/IEC 62305, "Protection against lightning" govern all lightning protection-related practices of a PV system.

10.1. The entire space occupying SPV array shall be suitably protected against lightning by deploying required number of lightning arresters. Lightning protection should be provided as per IS/ IEC 62305.

10.2. Lightning system shall comprise of air terminations, down conductors, test links, earth electrode etc. as per approved drawings.

10.3. The protection against induced high voltages shall be provided by the use of surge protection devices (SPDs) and the earthing terminal of the SPD shall be connected to the earth through the earthing system.

10.4. The EPC Contractor / Company shall submit the drawings and detailed specifications of the PV array lightning protection equipment to Employer for approval before installation of system.

## **11. ARRAY JUNCTION BOX (AJB)/ STRING COMBINER BOX (SCB)**

AJB shall be provided as per the design requirement of the Inverter, if required. AJB comprises of an enclosure, copper busbars, Fuses, Surge Protection Device (SPD) and Isolator. DC generated by the solar modules is transmitted through the appropriate cables from Array Yard to Control facility. AJB bus & panel shall be provided for the incoming DC supply from array yard.

AJB, if required, should be equipped with an adequate capacity indoor DC circuit breaker along with control circuit, protection relays, fuses, etc.

AJB, if required, shall have sheet from enclosure of dust and vermin proof, the bus bar / cables are to be made of copper of desired size.

The Array Junction Boxes are to be provided in the PV array for termination of connecting cables. The Array Junction Boxes shall be made of GRP/FRP/with full dust, water & vermin proof arrangement. All wires/cables must be terminated through cable lugs. The JB's shall be such that input & output termination can be made through suitable cable glands.

11.1. Suitable markings shall be provided on the bus bar for easy identification and the cable ferrules must be fitted at the cable termination points for identification.

11.2. Copper bus bars/terminal blocks housed in the junction box with suitable termination threads conforming to IP 65 standard to prevent water entry, Single/ double compression cable glands, provision of earthing. It should be placed at a height suitable for ease of accessibility.

11.3. Each Junction Box shall have high quality Suitable capacity Metal Oxide Varistors (MOVs)/ SPDs. The Surge Protective Device shall be of Type 2 as per IEC 60364-5-53

11.4. The junction Boxes shall have suitable arrangement for the followings (typical): - Combine groups of modules into independent charging sub-arrays that will be wired into the controller. The Junction Boxes shall have arrangements for disconnection for each group and attest point for sub-group for fault location. AJB/SCB shall be wired with optical fibre cables for enabling data collection for PV Plants from 100kWp onwards.

11.5. The current carrying ratings of the string combiner box/ junction box shall be suitable with adequate safety factor, to inter connect the Solar PV array.

11.6. All fuses shall have DIN rail mountable fuse holders and shall be housed in thermoplastic IP65 enclosures with transparent covers.

11.7. Fuse for both positive and negative inputs of each string, Isolator of MCB, SPD of type 2 shall be provided.

11.8. The surge arresters shall be type 2 (with reference to IEC 61643-1) rated at a continuous operating voltage of at least 125 percentage of the open-circuit voltage of the PV string, and a flash current of more than 5A.

11.9. Not more than two strings can be connected in parallel to a single input of SCB/AJB.

One spare input terminal along with connector shall be provided for each SCB/AJB.

11.10. Every SCB/AJB input shall be provided with fuses on both positive and negative side.

11.11. DC switch disconnecter of suitable rating shall be provided at AJB/SCB output to disconnect both positive and negative side simultaneously.

## **12. AC DISTRIBUTION BOARD**

AC Distribution Board (ACDB) shall control the AC power from inverter and should have necessary surge arrestors.

It shall have MCB/MCCB/ACB or circuit breaker of suitable rating for connection and disconnection.

12.1 The ACDB enclosure shall be of good protection and suitable for mounting on the trenches / on wall.

12.2 All the 415 V AC or 230 V AC devices/equipment like bus support insulators, circuit breakers, SFU isolators (if applicable), SPD, etc. mounted inside the switch gear shall be suitable for continuous operation

12.3 Switches/ circuit breakers/ connectors meeting general requirements and safety measurements as per IS 60947 Part I, II, III and IEC 60947 part I, II and III.

12.4 Junction boxes, enclosures, panels for inverters/ Controllers shall meet IP 54 (for outdoor)/ IP 65 (for indoor) as per IEC 529.

## **13. AC/DC CABLING**

Cabling is required for wiring from AC output of inverter/PCU to the Grid Interconnection point. It includes the DC cabling from Solar Array to AJB and from AJB to inverter input.

13.1. All cables of appropriate size to be used in the system shall have the following characteristic:

- a. Shall conform to IEC 60227 / IS 694 & IEC 60502 / IS 1554 standards.
- b. Temperature Range: -10 degree Celsius to +80 degree Celsius
- c. Voltage rating: 660/1000V
- d. Excellent resistance to heat, cold, water, oil, abrasion, UV radiation
- e. Flexible

13.2. Sizes of cables between any array interconnections, array to junction boxes, junction boxes to inverter etc. shall be so selected to keep the voltage drop (power loss) of the entire solar system to the minimum (2%).

13.3. For the DC cabling, XLPE or XLPO insulated and sheathed, UV stabilized single core flexible copper cables shall be used; multi-core cables shall not be used.

13.4. For the AC cabling, PVC or XLPE insulated and PVC sheathed single or, multi-core flexible copper cables shall be used. However, for above 25kWp systems, XLPE insulated

Aluminium cable of suitable area of cross section can be used in the AC side subject to a minimum area of cross section of 10 sq.mm. Outdoor AC cables shall have a UV –stabilized outer sheath IS/IEC 69947.

13.5. All LT XLPE cables shall conform to IS:7098 part I&II.

13.6. The total voltage drop on the cable segments from the solar PV modules to the inverter shall not exceed 2.0%

13.7. The total voltage drop on the cable segments from the solar grid inverter to the building distribution board shall not exceed 2.0%

13.8. The DC cables from the SPV module array shall run through a UV-stabilized PVC conduit pipe of adequate diameter with a minimum wall thickness of 1.5mm

13.9. Cables and wires used for the interconnection of solar PV modules shall be provided with solar PV connectors (MC4) and couplers

13.10. All cables and conduit pipes shall be clamped to the rooftop, walls and ceilings with 16hermos-plastic clamps at intervals not exceeding 50cm; the minimum DC cables size shall be 4.0mm<sup>2</sup> copper; the minimum AC cable size shall be 4.0mm<sup>2</sup> copper. In three phase systems, the size of the neutral wire size shall be equal to the size of the phase wires.

13.11. Cable Marking: All cable/wires are to be marked in proper manner by good quality ferule or by other means so that the cable can be easily identified. The following colour code shall be used for cable wires

- a. DC positive: red (the outer PVC sheath can be black with a red line marking)
- b. DC negative: black
- c. AC single phase: Phase: red; Neutral: black
- d. AC three phase: phases: red, yellow, blue; neutral: black
- e. Earth wires: green

13.12. Cables and conduits that have to pass through walls or ceilings shall be taken through PVC pipe sleeve.

13.13. Cable conductors shall be terminated with tinned copper end ferrules to prevent fraying and breaking of individual wire strands. The termination of the DC and AC cables shall be done as per instructions of the manufacturer, which in most cases will include the use of special connectors.

13.14. All cables and connectors used for installation of solar field must be of solar grade which can withstand harsh environment conditions including high temperatures, UV radiation, rain, humidity, dirt, salt, burial and attack by moss and microbes' for 25 years and voltages as per latest IEC standards. DC cables used from solar modules to array junction box shall solar grade copper (Cu) with XLPO insulation and rated for 1.1 kV as per relevant standards only.

13.15. Bending radii for cables shall be as per manufactures recommendations and IS: 1255.

13.16. For laying/termination of cables latest BIS/IEC Codes/ standards shall be followed.

## **14. CIVIL WORKS**

Existing shade-free roof-top space shall be used to install Solar PV array. While installing solar power plants on rooftops, the physical condition of the rooftop, chances of shading, chances water level rise in the rooftop during raining due improper drainage in the roof-top should be taken in to consideration.

- 14.1. PV array shall be installed in the terrace space free from any obstruction and/or shadow and to minimize effects of shadows due to adjacent PV panel rows.
- 14.2. PV array shall be oriented in the south direction in order to maximize annual energy yield of the plant.
- 14.3. The solar PV array must be installed on the rooftop in such a way that there is sufficient space on the rooftop for maintenance etc.
- 14.4. There should not be any damage what so ever to the rooftop due to setting up of the solar power plant so that on a later day there is leakage of rainwater, etc. from the rooftop.
- 14.5. Some civil works are inevitable for erecting the footings for the module mounting structure as discussed in Module Mounting Structure section. The roof top may be given a suitable grading plaster with suitable leak proof compound so as to render the roof entirely leak proof.
- 14.6. Ample clearance shall be provided in the layout of the inverter and DC/AC distribution boxes for adequate cooling and ease of maintenance.
- 14.7. While cabling the array, care must be taken such that no loose cables lie on the rooftops.
- 14.8. The roof top should look clean and tidy after installation of the array.
- 14.9. Neatness, tidiness and aesthetics must be observed while installing the systems.
- 14.10. RCC Works – All RCC works shall be as per IS 456 and the materials used viz. Cement reinforcement, steel etc. shall be as per relevant IS standards. Reinforcement shall be high strength TMT Fe 415 or Fe 500 conforming to IS: 1786-1985.
- 14.11. Brick Works (If any) – All brick works shall be using 1st class bricks of approved quality as per IS 3102.
- 14.12. Plastering – Plastering in cement mortar 1:5, 1:6 and 1:3 shall be applied to all.
- 14.13. Display of mandatory items- Single Line Diagram and layout diagram of modules and interconnection at installation site shall be provided near the inverter for greater than 10 kWp systems.
- 14.14. For painting on concrete, masonry and plastered surface IS:2395 shall be followed. For distemping IS 427 shall be followed referred. For synthetic enamel painting IS 428 shall be followed. For cement painting IS 5410 shall be followed.
- 14.15. All Civil works required for the installation of the PV Plant and other civil wherever necessary, shall be within the scope of the bidder
- 14.16. The layout of Inverter accommodation shall be designed to enable adequate heat dissipation and availability. Mount within the existing infrastructure available in consultation with the Site in charge.
- 14.17. The Inverter and Battery should be place as near as possible in the near vicinity of PV array to avoid voltage drop.
- 14.18. They shall be enough ventilation for the battery room

## **15. WARRANTY**

1. Five years system warranty should be provided by the EPC contractor for the equipment and the components installed.
2. The successful bidder should submit the copies of the Warrantee Certificates for the on-site warrantee provided by the OEM for the important components like PV Modules, Inverters, Junction Boxes, Batteries etc.
3. The warrantee/CMC modalities is between the customer and the EPC company.

## 16. OPERATION MANUAL

An Operation, Instruction and Maintenance Manual, should be provided with the system. The following minimum details must be provided in the manual:

- About solar power plant – its components and expected performance.
- DO's and DON'T's
- Cleaning of Solar PV Modules in regular intervals
- Clear instructions on regular maintenance and troubleshooting of solar power plant.
- As built drawings for the installation
- Five Year System Warrantee/CMC Certificate
- OEM Warrantee Certificates of Inverters, PV Modules, Batteries etc.
- Specification of PV Power Plant
- Data Sheets of Major Equipment like PV Module/Inverter etc.
- Name and address of the E.P.C Contractor and the contract person in case of non-functionality of the solar power plant.

## 17. BILL OF MATERIALS

Once Empanelled and when a project is awarded the EPC Contractor should provide the bill of material mentioning the quantity of each of the item consisting in the system, for the projects they are undertaking.

The format for the Bill of Materials is given below:

Sl. No.	Item	Make (If any)	Model& Individual Capacity (If any)	Quantity (Nos)	Rating/Capa city
1.	PV Module				
2.	PCU/Inverter				
3.	Battery				
4.	DC Cables				
5.	AC Cables				
6.	AJB/SCB				
7.	ModuleMoun ting  Structure (MMS)				

8.	DCDB				
9.	ACDB				
10.	Lightning Arrester				
11.	Earthing System Details and No. of Earth pits				

## 18. SITE INSPECTION

Once Empanelled and when a project is awarded the EPC Contractor should visit site / sites for the checking the feasibility before proceeding. The load proposed to be segregated and connected to the Off-Grid PV Plant should match with the connected load.

## 19. DRAWINGS AND DOCUMENTS

Once Empanelled and when a project is awarded the EPC contractor must submit drawings/documents required by statutory authorities and obtain the approval before the installation.

- i) Schematic drawing showing the PV panels, Power conditioning Unit(s)/Inverter, Array Junction Boxes (AJBs)/String Combiner Boxes (SJB), AC and DC Distribution Box, Battery bank etc.
- ii) Layout of solar PV Array
- iii) Single Line Diagram (SLD) with specification of all components.
- iv) Design document for Module Mounting Structure (MMS) including certificate showing wind speed withstanding capacity of the structure (STAAD/Equivalent).
- v) Module Mounting Structure (MMS) drawing along with foundation details for the structure.
- vi) Sizes and specification of cables for PV Module interconnections, PV Array to Array Junction Boxes, Array Junction Boxes to Inverter, Inverter to ACDB etc. shall be furnished.

All PV plant design should contain the following details which should be approved by the concerned officer before installation.

- i) Design of string including the number of PV modules in series and number strings
- ii) AC Protection (Circuit Breaker, Switches, Fuses, SPD)
- iii) DC Protection (Switches, Fuses, SPD)
- iv) AJB/ Junction Box details
- v) DC Cable size and length from point to point
- vi) AC Cable size and length from point to point
- vii) Earthing system details and number of pits v ii i) Lightning protection detail/specification

## 20. DUTY CYCLE

The system should be capable for operating the required no. of hours based on the design of the PV Power Plant. There are three options for battery backup 2hrs/ 3h hrs / 6hrs.

## **21. ATS PANEL FOR AUTOMATIC CHANGE OVER**

There should be an ATS Panel incorporated with an Automatic Change-over System for Changing from PV System to Grid/DG whenever the PV System could not provide the sufficient Power to the Load. The ATS Panel shall get the Power Supply from the existing Grid. The inverter must be prevented from charging the battery from Grid at any circumstance.

## **22. LOAD SEGREGATION AND CONNECTED LOAD**

Connected Load to the PV OFF-Grid System should be within limits of the specifications of the Inverter/Power Conditioning System. Load Segregation is the responsibility of the EPC Contractor to suit to the capacity of the Inverter and there shall be a vertical DB for the segregated load as per the needs of the building:

The load segregation and interconnection of load with inverter output and change of load should be done after assessing the actual load conditions at the site.

All the electrical works required for the interconnection of load with inverter output should be done by the successful bidder as a part of the Solar Power Plant installation.

If additional wiring is required for segregating the load then that work should also be done as a part of this project implementation

## **23. MANUAL CHANGE- OVER SWITCHES**

Necessary Change-over switches (4-pole 2-way for 3-ph and 2-pole 2-way for 1-ph) shall be provided by the supplier to connect the PCU to the load. The change-over switch shall be used to the load to utility power.

The above Change - Over Switch will be the additional emergency requirement if the ATS Panel /Automatic Change-Over Switch fails.

### **END OF SECTION**

## **SECTION 21000- GROUNDING AND BONDING FOR ELECTRICAL SYSTEMS**

### **PART 1 GENERAL**

#### **1.1 Description of Work**

1. Complete installations to earth every source of energy and to provide protective earthing and equipotential bonding, based on the TN-S system arrangement as defined in IEC60304, including:
  - 2.

##### **1.1.1.1 Main earthing terminals or bars**



1.1.1.2 Exposed conductive parts of electrical equipment

1.1.1.3 Extraneous conductive parts

## **1.2 Regulations and Standards**

1.2.1 Carry out work in accordance with the following:

1.2.1.1 Local codes and regulations (if any)

1.2.1.2 IEC publications IEC 60364-3 and 60364-4-41 Electrical Installations in Buildings

1.2.1.3 Latest edition of IEE Regulations for Electrical Installations in Buildings - London.

## **1.3 Definitions of Terms**

1.3.1 Used on the Drawings and in the Specification are as follows:

1.3.1.1 Earth

Conductive mass of the Earth whose electric potential at any point is conventionally taken as zero.

1.3.1.2 Earth Electrode

Conductor or group of conductors in initial contact with and providing electrical connection to Earth.

1.3.1.3 Exposed Conductive Part

Any part which can be readily touched and which is not a live part, but which may become live under fault conditions.

1.3.1.4 Extraneous Conductive Part

Any conductive part not forming part of the electrical installation such as structural metalwork of a building, metallic gas pipes, water pipes heating tubes etc. and non- electrical apparatus electrically connected to them i.e., radiators, cooking ranges, metal sinks etc. and non-insulating floors and walls.

1.3.1.5 Protective Conductor

Conductor used for some measure of protection against electric shock and intended for connecting together any of the following parts:

- a. Exposed conductive parts
- b. Extraneous conductive parts
- c. Earth electrode(s)
- d. Main earthing terminal or bar(s)
- e. Earthed point of the source(s)

Protective conductor shall be equal to phase conductor for all phase conductors up to and including 16 mm. sq. Protective conductor shall be equal to half size (or next standard to half size) phase conductor, for phase conductor equal or larger than 25 mm. sq.

#### 1.3.1.6 Electrically Independent Earth Electrodes

Earth electrodes located at such distance from one another that maximum current likely to flow through one of them does not significantly affect the potential of the other(s).

#### 1.3.1.7 Main Earthing Terminal or Bar

The terminal or bar provided for the connection of protective conductors, including equipotential bonding and functional earthing conductors if any to the means of earthing.

#### 1.3.1.8 Equipotential Bonding

Electrical connection to put exposed and extraneous conductive parts at a substantially equal potential.

#### 1.3.1.9 Earthing Conductor

Protective conductor connecting main earthing terminal or bar of an installation to earth electrode or to other means of earthing.

### 1.4 Equipment Data

1.4.1 Prior to ordering materials, submit data for approval including, but not limited to, manufacturer's catalogues for earth rods, connecting clamps, earthing conductors, protective conductors, bonding conductors, connectors and other accessories, exothermic welding kits and tools etc., and samples of conductors as requested.

### 1.5 Shop and Construction Drawings

1.5.1 Submit drawings for approval including, but not limited to, the following:

1.5.1.1 Exact location of earth pits, rods and details of installation and connections.

1.5.1.2 Exact routing of buried earthing conductors with indication of cross-section, depth of laying and covering.

1.5.1.3 Cross sectional area of all earthing, protective and bonding conductors.

1.5.1.4 Layout and details of earthing provisions at substations, generator rooms, switch distribution panel boards etc., indicating fittings used, insulation, plates and marking, passage and routing of earthing conductors, conduit, sleeves, grooves, niches etc., giving sizes and dimensions of component parts.

## PART 2 PRODUCTS

### 2.1 Products and System

2.1.1 Earthing System (Type TN-S)

2.1.1.1 General Requirements

2.1.1.2 Component Parts of earthing system are to include the following:

- a. Earth electrode (rods, tapes etc.)
- b. Main earthing terminals or bars
- c. Earthing conductors
- d. Protective conductors
- e. Equipotential bonding conductors

f. -Accessories and termination fittings, bonding, welding kits and other materials.

2.1.1.3 Earth Electrodes is to consist of one or more earth rods, interconnected by buried earthing tape or cable, installed under finish of ground floor, as an interconnection through buried grounding grid at 60cm below ground is not feasible due to waterproofing problem. Earth electrode shall have a total combined resistance value, during any season of the year and before interconnection to other earthed systems or earthing means, not exceeding 5 ohms. If it is difficult to get the obtained 5 ohms add Macronite conductive aggregate in place of sand to the cement. Distance between two rods is not to be less than the length of one rod, or 3 m minimum.

2.1.1.4 Functional Earth Electrode is to be provided separately from, but interconnected to, other earth electrode(s) through suitably rated (470 V) spark gap. Functional earth electrodes are to be used for earthing electronic equipment (communication equipment, digital processors, computers etc.) as required by the particular Section of the Specification and recommendation of manufacturer.

2.1.1.5 Alternative Earth Electrode other types of earth electrode may be used, after approval, including:

- a. Cast iron pipes with special surround material
- b. Copper plate(s)
- c. Tape mats (strips)

2.1.1.6 Earth Fault Loop Impedance for final circuits supplying socket outlets, earth fault impedance at every socket outlet is to be such that disconnection of protective device on over current occurs within 0.4 seconds, and for final circuits supplying only fixed equipment, earth fault loop impedance at every point of utilization is to be such that disconnection occurs within 5 seconds. Use appropriate tables and present same for approval by the Engineer (IEE Regulations: Tables 41A1 and 41A2, Appendix 7 and regulation 543).

2.1.1.7 Supplementary Equipotential bonding all extraneous conductive parts of the building such as metallic water pipes, drain pipes, other service pipes and ducting, metallic conduit and raceways, cable trays and cable Armour are to be connected to nearest earthing terminals by equipotential bonding conductors. Cross-section of protective bonding conductor is not to be less than half that of the protective conductor connected to respective earthing terminal and minimum 4 mm<sup>2</sup>.

2.1.1.8 Main Equipotential Bonding main incoming and outgoing water pipes and any other metallic service pipes are to be connected by main equipotential bonding conductors to main earth terminal or bar. Bonding connections are to be as short as practicable between point of entry/exit of services and main earthing bar. Where meters are installed, bonding is to be made on the premises side of the meter. Cross-sections of conductors are not to be less than half that of the earthing conductor connected thereto, and minimum 6 mm<sup>2</sup>.

2.1.1.9 Identification connection of every earthing conductor to earthing electrode and every bonding conductor to extraneous conducting parts is to be labelled in accordance with the Regulations, as follows:

2.1.1.10 Safety electrical connection - do not remove.

2.1.1.11 Identification protective and earthing conductors are to be identified by combination of green-and-yellow colours of insulation or by painting bar conductors with these colours, as approved.

2.1.1.12 Identification source earthing conductor (or neutral earthing conductor) is to be identified along its entire length by continuous black insulation labelled, 'neutral earthing'.

## 2.2 Transformer Substation Earthing

2.2.1 Mv switchgear is to have separate main earthing bar connected to framework or earth bar of each item by bare conductor and the earth-electrode by two insulated earthing conductors, one at each end of bar, via testing joints. earthing conductor is to be minimum 50 mm<sup>2</sup>.

2.2.2 Contractor to coordinate with Local Electricity Company for the earthing of the main switchgear.

2.2.3 LV Switchgear is to have separate main earthing bar connected to framework or earth bar of each item by bare conductor and the earth electrode at two extreme ends by two insulated earthing conductors through testing joints. Earthing conductor size is to be minimum 120 mm<sup>2</sup>.

2.2.4 Transformer earthing terminal is to be connected to lv main earthing bar by bare copper earthing conductor not less than 120 mm<sup>2</sup> per 100 KVA of transformer rating, with a minimum of 35 mm<sup>2</sup>.

2.2.5 transformer neutral (star point) is to be connected by insulated earthing conductor (colour black) to lv side main earthing bar. neutral earthing conductor is to be sized for maximum earth fault current for 5 seconds with final conductor temperature not exceeding 160 deg. c or sized not less than 300 mm<sup>2</sup> per 100 KVA of transformer rating, and with a minimum of 50 mm<sup>2</sup>. where a neutral is directly connected to earth electrode, an insulated disconnecting device is to be provided at the transformer.

2.2.6 lightning arresters are to be directly connected to earth electrode, following the shortest path. each lightning arrester is to be connected at a dedicated earth rod.

## **2.3 Earthing of Main Distribution Boards, Panel boards, Lighting Installations and**

### **Wiring Accessories**

2.3.1 Main earthing bar is to be provided in main distribution room and connected to earth electrode by two insulated conductors (minimum 120 mm<sup>2</sup>) via testing joints.

2.3.2 Earthing bars of main distribution boards are to be connected, by bare earthing conductor, directly to main earthing bar at main distribution room and by protective conductor run with incoming feeder from respective supply point.

2.3.3 Distribution, lighting and power panel boards are to be connected by protective conductors run together with incoming feeder cable, connecting earth terminals in panel boards with respective main distribution board earthing bar.

2.3.4 Socket outlets are to be earthed by protective conductor looped around with the branch circuit and connected to earth terminal within socket outlet box and to which socket outlet terminal is to be connected.

2.3.5 Final ring subcircuits: protective conductor of every final ring sub-circuit is to be in the form of a ring having both ends connected to earth terminal at origin of circuit in panel board.

2.3.6 Lighting fixtures and other exposed conductive parts of electrical installations, such as switches, heaters, air conditioning units etc. are to be connected by protective earth conductors to earthing terminals of respective panel boards.

## **2.4 Generator Plant Earthing**

2.4.1 Generator neutral (star point) is to be connected by insulated earthing conductor through the neutral earthing link or device to main earthing bar. neutral earthing conductor is to be suitably sized to carry maximum earth fault current for time it takes the system protection to operate with final conductor temperature not exceeding 160 deg. c, but not less than 300 mm<sup>2</sup> per 100 KVA of generator rating, with a minimum of 50 mm<sup>2</sup>.

2.4.2 Generator earthing terminal is to be connected to main earthing bar by bare copper conductor of cross section not less than 120 mm<sup>2</sup> per 100 kva of generator size, with a minimum of 35 mm<sup>2</sup>.

2.4.3 Switchgear (ats) and control gear: earthing terminals or bars of switchgear and control gear are to be connected by separate protective conductors to respective normal and emergency main distribution board earth bars.

2.4.4 Extraneous conductive parts including steel frames, battery racks, day-tank, pumps and piping are to be connected by bare copper earthing conductors to main earth bar in compliance with bonding regulations.

## **2.5 Mechanical Plant Rooms and Fixed Machinery**

2.5.1 Main earthing bar or loop is to be conveniently located in mechanical plant rooms, and connected by earthing conductors to exposed conductive parts of motor control center at its earthing bar, and to motors, switches and other electrical equipment etc. at their earthing terminals, using 20 x 2 mm bare copper strips or 35 mm<sup>2</sup> bare copper conductor (minimum size) or as required to carry maximum earth fault current for 1 second with final conductor temperature not exceeding 200 deg. c. conductors are to be securely fixed, recessed in floor grooves or niches, or fixed to walls by appropriate staples. earth bar or loop is to be securely fixed to building wall with copper or brass saddles.

2.5.2 Main earthing bar or loop is to be connected at two extremely separate points to earth electrode, directly through two test joints by insulated earthing conductors, or connected to main earth bar by protective conductors.

2.5.3 Motor and other equipment earth terminals are to be connected also by protective earth conductors of each branch circuit to earth terminal/bar at motor control centre, panel or distribution unit.

## **2.6 Materials and Products**

### **2.6.1 Earth rod**

2.6.1.1 Copper steel, 25 mm diameter, 3 m length, extendible as necessary to obtain required earth resistance. Earth rod is to be complete with couplings, head and bolted connector of sufficient size, and number of bolted clamps to channel cables terminated thereto.

### **2.6.2 Buried Earth Conductors**

2.6.2.1 Bare annealed copper strip conductors 25 x 2.5 mm, or annealed stranded copper conductors 70 mm<sup>2</sup> cross-section.

2.6.2.2 Tape mats: where earth rods are not likely to be used, earth electrode is to consist of parallel and perpendicular copper strip, 2.4 m apart, welded together by exothermic welds to form a grid. tape is to be 25 x 2.5 mm strip conductor.

### **2.6.3 Earth Pit.**

2.6.3.1 Pre-cast, square or circular section concrete hand hole (minimum 450 mm internal diameter), with concrete cover, and extending to about 150 mm below top of earth rod. Earth pit is to be provided for each earth rod were connected to an earthing conductor. Cover is to have inset brass plate with inscription 'Earth Pit - Do Not Remove'.

### **2.6.4 Earthing Conductors.**

2.6.4.1 Insulated or bare copper conductor as described in the Specification for the particular application.

#### 2.6.5 Testing Joints (Test Links)

2.6.5.1 Copper or copper alloy, with bolted end connections, disconnect able by use of tool, and suitably sized for earthing conductors or earth bar connection. Links are to be fixed to porcelain or other approved insulating supports. Contact surfaces are to be tinned.

#### 2.6.6 Protective Conductors

2.6.6.1 Single core stranded annealed copper, PVC insulated cables, having rated insulation grade compatible with circuit protected, or to be a conductor forming part of a multi-core cable, colour coded.

#### 2.6.7 Main Earthing Bar

2.6.7.1 Hard drawn copper, 40 x 4 mm where, formed into a closed loop, and 50 x 6 mm were open-ended. Earth bar is to be labelled 'Main Earth Bar' and is to be drilled, for connection of conductors, at a spacing not less than 75 mm, and is to be supplied with copper alloy bolts, nuts and washers and wall mounting insulators.

#### 2.6.8 Protective Bonding Conductors

2.6.8.1 Bare copper strip conductors, annealed stranded copper cable (high conductivity copper wire to BS4109-C101) or flexible strap (flexible braid) of cross-sectional area as required by applicable code.

#### 2.6.9 Earthing Accessories

2.6.9.1 Copper or copper alloy, purpose made, of approved design, compatible with points of connection, and of adequate cross-section and current carrying capacity. Connectors and clamps are to be bolted type. Bolts, nuts and washers are to be high quality phosphor bronze or copper silicon alloys.

### **PART 3 EXECUTION**

#### **3.1 Field and Installation Work (Installation)**

3.1.1 Continuity: ensure that complete earthing system is electrically continuous and mechanically secure.

3.1.2 Earth Rods: while sitting earth rods, ensure that resistance areas associated with individual rods do not overlap. Earth rods are to be located at a distance greater than 600 mm from foundations of buildings. Where rock is encountered, a hole of sufficient size is to be drilled before lowering the rod. Macronite conductive aggregate is to be provided around the rod.

3.1.3 Buried Earthing Conductors are to be laid at a depth not less than 0.8 m from grade.

3.1.4 Earthing Conductors are to follow shortest path between earth rods and main earthing terminals or bars, and are to run in PVC conduit (duct) fastened to building structure by approved supports and extending 0.2 m above level, and are to be protected against mechanical damage and corrosion.

3.1.5 Protective Conductors: separate protective conductors, which are not part of a cable, are to be fixed on same support or drawn into same conduit as circuit conductors.

3.1.6 Protective Bonding: remove any non-conductive paint, enamel or similar coating at threads, contact points and surfaces and ensure that bonding is made by fittings designed to make secure bonds.

3.1.7 Protection against Corrosion: protect bolted connections against corrosion either by filling with Vaseline or coating with a special anti-corrosion compound and proper capping.

3.1.8 Connections: earth connections are to be readily accessible. If inaccessible earth connection is permitted, approved exothermic welding or brazing technique is to be employed.

3.1.9 Connections: where earth connections between dissimilar metals must be made, use bimetallic fittings and protect by coating with moisture resisting bituminous paint or compound, or by wrapping with protective tape to exclude moisture.

## **3.2 Tests on Site and Records**

3.2.1 Combined Resistance of earth electrodes is to be measured during dry season and checked against specified resistance.

3.2.2 Electrical Continuity of all earthing and protective conductors including main and supplementary equipotential bonding conductors is to be checked.

3.2.3 Earth Fault Loop Impedance of all circuits is to be measured and checked against calculated impedance figures.

3.2.4 Records: submit the following:

3.2.4.1 Scaled drawings, as-installed, showing actual layout and specification of all components of earthing system.

3.2.4.2 Nature of soil and any special earth arrangements etc.

3.2.4.3 Date and particulars of soil conditioning method and agents if used.

3.2.4.4 Test conditions and results obtained.

3.2.5 Operating and maintenance manuals are to contain the following:

3.2.5.1 Technical description of each system and item of equipment installed, written to ensure that the Employer's staff fully understand the scope and facilities provided

3.2.5.2 Diagrammatic drawings of each system indicating principal components and items of equipment

3.2.5.3 Schedules (system by system) of equipment installed giving manufacturer, catalogue list numbers, model, rating, capacity and operating characteristics; each item is to have a unique code and number, cross-referenced to the diagrammatic drawings and layout drawings

3.2.5.4 Name, address, telephone, fax numbers and email address of the manufacturer of every item of equipment

3.2.5.5 Name, address, telephone, fax numbers and email address of equipment agents/representatives for emergency services and procedures.

3.2.5.6 Manufacturer's service manual for each major item of equipment, assembled specifically for the project, including detailed drawings, illustrations, circuit details, operating and maintenance instructions, modes of operation, control provisions, sequences and interlocks and preventative maintenance programme

3.2.5.7 Schedules of all fixed and variable equipment settings established during commissioning.

3.2.5.8 Procedures for fault finding, where applicable

3.2.5.9 Manufacturers' lists of recommended spare parts for items subject to wear and deterioration, giving expected running period and indicating specifically those items which may involve extended deliveries.

3.2.5.10 Prepare two temporary copies with provisional record drawings and preliminary performance data and make available at time of testing and commencement of commissioning to enable the Employer's staff to familiarize themselves with the installations. Temporary copies are to be in the same format as the final manuals with temporary insertions for items, which cannot be finalized until installations are commissioned, and performance tested.

### **3.3 Training**

3.3.1 Operation and maintenance training: before the date of substantial completion, explain and demonstrate to the employer's maintenance staff the purpose, function and operation of the installations including all items and procedures listed in the operating and maintenance manuals.

**THE END**



**United Nations Children Fund (UNICEF)**

**Environmental and Social Safeguards Requirement for  
Construction of Schools**

Date [31-08-2023]

## Table of Content

Environmental and Social Safeguards Minimum Requirements .....	2
Environmental, Social (including labour), Health, and Safety (ESHS) Requirements .....	5
Contractor Environmental and Social Reporting .....	16
Code of Conduct .....	18
Training and Capacity Building Plan.....	21
Occupational Health and Safety (OHS) Management Plan.....	23
Traffic Management Plan (TMP).....	25
Traffic Management Plan (TMP).....	27
Incident Reporting Logbook.....	30

## **1 Environmental and Social Safeguards Minimum Requirements**

The sub-project's environmental and social safeguard assessment shall confirm that there will be no land acquisition or negligible risk of significant negative impacts from the construction of schools on environmental and social aspects. As an essential requirement for environmental and social safeguards, the Implementing Partners and contractor shall ensure that the ESS requirements and instruments are developed and implemented through project implementation.

### ***1.1. Site Selection and Land Acquisition***

Implementing Partners (NGOs), through their contractors, shall ensure that the planned activities will be carried out within the current school's footprint, involving no land acquisition. The sanitary facilities should be at least 50 meters from classrooms and public property, and at least 25 meters away from potable/surface water. If there is not sufficient space, the location of the sanitary facilities should be chosen taking wind direction into account to prevent smell defusing to the classroom and surrounding environment. Additionally, the sanitary facilities should be in areas that can be easily supervised and evenly distributed throughout the school.

### ***1.2. Vegetation and Tree Cutting***

Implementing Partners (NGOs), through their contractors, shall ensure that the project's operations won't result in the cutting down of trees or the mutilation, slashing, or tampering with of the surrounding environment. In the event that there is not sufficient space, the contractor shall plant three trees in the current school's footprint in place of each cut tree.

### ***1.3. Demolition of Existing Structures***

Implementing Partners (NGOs), through their contractors, shall save all existing structures, pipes, cables, sewers, or other services or installations during the project implementation.

### ***1.4. Construction Waste Generation***

Implementing Partners (NGOs), through their contractors, shall ensure that all waste generated by contractor camp operations, excavation, and construction activities is managed properly and disposed of appropriately in the designated site by the local governor or municipalities.

### ***1.5. Resource efficiency and Pollution***

Implementing Partners (NGOs), through their contractors, shall ensure that the environmental, social, health, and safety (ESHS) requirements (Annex-I) and proposed mitigation measures are put into place during the construction activities in order to manage, mitigate, minimize, and reduce the pollution of the air, water, noise, and soil.

### ***1.6. Occupational Health and Safety and Community Health and Safety (CHS)***

Implementing Partners (NGOs), through their contractors, shall ensure that a site-specific occupational health and safety (OHS) management plan is developed and implemented during the project's construction phase. This plan should include information on the organization and capacity, roles and responsibilities, personnel protective equipment, compensation based on Afghanistan's national labor laws and regulations, training, and capacity building.

**1.7. Incidents and Accidents**

Implementing Partners (NGOs), through their contractors, shall ensure that appropriate incident and accident reporting and handling procedures have been established, including those for internal and external reporting, first aid, compensation, and training for both technical and non-technical workers.

**1.8. Security**

Implementing Partners (NGOs) and contractors are accountable for the safety of their workers, locations, possessions, and operations. They shall ensure that their employees receive sufficient training on safety and security issues that are appropriate for the Afghan context, including conflict-sensitive communication, cultural awareness, implementation, and risk management, and they must immediately communicate to UNICEF any security-related issues that have a negative impact on program delivery or personnel.

**1.9. Road safety and Accidents**

Implementing Partners (NGOs), through their contractors, shall ensure that a site-specific Traffic Management Plan (TMP) is developed and implemented during the project construction phase and includes responsibilities and responsibilities, emergency response and reporting procedures, compensation based on Afghanistan's national labor laws and regulations, training, and capacity building for all drivers and other relevant employees.

**1.10. Emergency Preparedness and Response**

Implementing Partners (NGOs), through their contractors, shall ensure that a site-specific emergency preparedness and response (EPR) plan is developed and implemented, all technical and non-technical employees and staff are trained. The plan should include roles and duties, emergency response procedures, internal and external reporting procedures.

**1.11. Communicable Diseases**

Implementing Partners (NGOs), through their contractors, shall implement a combination of behavioral and environmental modification to mitigate communicable disease risks and impacts.

**1.12. Facilities for Project Workers**

Implementing Partners (NGOs), through their contractors, shall ensure that both the project site and the contractor camp have adequate lavatory facilities (toilets and washing places), and that portable and drinking water are properly provided for project workers.

**1.13. Stakeholder Engagement**

Implementing Partners (NGOs), through their contractors, shall ensure that before, during, and after the project's implementation, every relevant stakeholder, including provincial and district level MoE directorates, community representatives, Schools Management Shuras (SMS), and school's principals, are engaged and involved.

**1.14. Grievances Mechanism (GM)**

Implementing Partners (NGOs), through their contractors, shall ensure that a grievance system including the PSEA hotline and the PSEA confidential email address is set up at the project level and that all communities, teachers, and project workers (technical, skilled, and unskilled labor) are properly informed of the reporting channels and handling procedures. In addition, UNICEF will encourage the use of its innovative SMS-based mechanisms (U-Report and Rapid-Pro), as well as the interagency system Awaaz, to receive feedback from impacted populations.

**1.15. Labour Force Management**

Implementing Partners (NGOs), through their contractors, shall ensure that a project labor management procedure is in place, that all technical and non-technical worker terms and conditions comply with Afghanistan labor laws and regulations, that they are informed of the project grievance procedure, and that no child or forced labor is employed in the project activities.

**1.16. Sexual Exploitation and Abuse (SEA)/ Sexual Harassment (SH)**

Implementing Partners (NGOs), through their contractors, shall ensure the availability of a functional grievance redressal mechanism at the project level that can be used as a reporting channel with specific referral pathways for GBV/SEA/SH. As well as ensure that all project workers (technical and non-technical staff) receive training on sexual exploitation and abuse and sign a code of conduct.

**1.17. Training and Capacity Building**

Implementing Partners (NGOs), through their contractors, shall ensure that all project employees, both technical and non-technical, receive continuous capacity-building training on minimizing environmental and social risks and managing their effects.

**1.18. Environmental, Social, Health and Safety (ESHS) Officer**

Implementing Partners (NGOs) will be required to have in place dedicated ESS staff (ESHS Officer) who will be supported by project key staff and will be in charge of management, monitoring, and reporting of environmental and social safeguards. The contractor will be in charge of setting up an ESS focal point and will be in charge of implementing the social and environmental safeguards instruments in the project site.

**1.19. Monitoring and Reporting**

Implementing Partners (NGOs) are required to monitor and report on environmental and social mitigation measures implementation, including project-level grievance handling and reporting, stakeholder and beneficiary engagement, community health and safety, occupational health and safety, personnel protective equipment (PPEs), compensation based on national law and regulation, OHS, TMP, EPRP, land acquisition, site selection, forced, and child labors.

## 2 Environmental, Social (including labour), Health, and Safety (ESHS) Requirements

Implementing Partners (NGOs) shall ensure that the contractors meet the following Environmental, Social (including labor), Health and Safety requirements thereafter called ESHS requirements and fully implemented in the project sites during the project implementation.

### 2.1. Use of generic ESMP

The Contractor shall:

- Prepare a detailed explanation of how the contractor's performance will meet the ESHS requirements. Ensure that sufficient funds are budgeted to meet the ESHS requirements, and that sufficient capacity is in place to oversee, monitor and report on ESMP performance.
- Put in place controls and procedures to manage their ESHS performance.
- Get prior written approval from UNICEF engineers/technical extenders before starting construction or rehabilitation activities.

### Environmental, Social, Health and Safety (ESHS) Training

The Contractor shall:

- Determine ESHS training needs in collaboration with UNICEF/NGO's responsible teams (engineers/technical extenders).
- Maintain records of all ESHS training, orientation, and induction.
- Ensure, through appropriate contract specifications and monitoring, as well as all labor, are trained adequately before assignments begin.
- Demonstrate that its employees are competent to carry out their activities and duties safely. For this purpose, the contractor shall issue a competence certificate for every person working on site (relative to trade and aspect of work assignment) that specifies which tasks can be undertaken by which key personnel.

#### a. Orientation Training

The Contractor shall:

- Provide ESHS orientation training to all employees, including management, supervisors, and workers, so that they are apprised of the basic site rules of work at/on the site and of personal protection and preventing injury to fellow employees.
- Training should consist of basic hazard awareness, site-specific hazards, safe work practices, and emergency procedures for fire, evacuation, and natural disaster, as appropriate. Any site-specific hazard or color coding in use should be thoroughly reviewed as part of orientation training.

#### b. Visitor Orientation

The Contractor shall:

- Establish an orientation program for visitors, including vendors, that could access areas where hazardous conditions or substances may be present.
- Visitors shall not enter hazard areas unescorted.
- Ensure that visitors shall always be accompanied by an authorized member of the contractor, or a representative of Implementing Partners (NGO), who has successfully fulfilled the ESHS orientation training, and who is familiar with the project site construction hazards, layout, and restricted working areas.

### c. New Task Employee and Contractor Training

The Contractor shall:

- Ensure that all workers, prior to commencement of new assignments, have received adequate training and information enabling them to understand work hazards and to protect their health from hazardous ambient factors that may be present. The training should adequately cover the step-by-step process that is needed for project activities to be undertaken safely, with minimum harm to the environment, including:
  - Knowledge of materials, equipment, and tools.
  - Known hazards in the operations and how they are controlled.
  - Potential risks to health.
  - Precautions to prevent exposure.
  - Hygiene requirements.
  - Wearing and use of protective equipment and clothing.
  - Appropriate response to operation extremes, incidents, and accidents.
  - Construction Site Management.

## 2.2. Construction Site Management

### 2.2.1. Vegetation

The Contractor shall:

- Prevent any unnecessary destruction, scarring, or defacing of the natural surroundings in the vicinity of the construction site.
- Protect all trees and vegetation from damage by construction operations and equipment, except where clearing is required for permanent works, approved construction roads, or excavation operations.
- Revegetate damaged areas on completion of the works, and for areas that cannot be revegetated, scarifying the work area to a condition that will facilitate natural revegetation, provide for proper drainage, and prevent erosion.
- Use, as much as possible, local species for replanting and species that are not listed as a noxious weed.
- Repair, replant, reseed or otherwise correct, as directed by UNICEF engineers/technical extenders or its Implementing Partners (NGO), and at the Contractor's own expense, all unnecessary destruction, scarring, damage, or defacing of the landscape resulting from the Contractor's operations.
- Transport labor and equipment in a manner to avoid as much as possible damage to grazing land, crops, and property.

### 2.2.2. Protection of the Existing Installations

The Contractor shall:

- Safeguard all existing buildings, structures, works, pipes, cables, sewers, or other services or installations from harm, disturbance or deterioration during construction activities.
- Coordinate with School's Management Shuras and School's Principals to identify existing infrastructure that might not be visible.
- Repair any damage caused by the Contractor's activities, in coordination School's Management Shuras and School's Principals or concerned authorities.
- Take all reasonable precautions to prevent or reduce any disturbance or inconvenience to the owners, tenants, or occupiers of properties to the construction activities, and more

generally to the public.

- Maintain safe access to public and private properties that might be affected by construction activities. If necessary, provide acceptable alternative means of passage or access to the satisfaction of the persons affected.
- Avoid working during night hours

### **2.2.3. Waste from Construction Activities**

The Contractor shall:

- Collect and properly manage all solid wastes resulting from the construction activities, including construction debris and spoils, to prevent the contamination of soil and groundwater.
- Remove unneeded excavation material from construction sites as soon as possible.
- Agree with relevant municipalities about construction waste disposal.
- Carefully select waste disposal sites, to be approved by local authorities.
- Minimize littering of roads by ensuring that vehicles are licensed and loaded in such a manner as to prevent falling off or spilling of construction materials, and by sheeting the sides and tops of all vehicles carrying mud, sand, other materials, or debris.
- Transfer construction waste to assigned places in the selected waste disposal sites with documented confirmation.
- Properly dispose of solid waste and debris at designated permitted sites waste disposal sites allocated by the local authorities and obtain a receipt of waste from the authorized landfill authority.

### **2.2.4. Air Quality**

The most common pollutant involved in fugitive emissions is dust or particulate matter (PM) that is released during the transport and open storage of solid materials, and from exposed soil surfaces, including unpaved roads. accordingly, the Contractor shall:

- Use dust control methods, such as covers, water suppression, or increased moisture content for open materials storage piles, or controls, including air extraction and treatment through a baghouse or cyclone for material handling sources, such as conveyors and bins.
- Use water suppression for control of loose materials on paved or unpaved road surfaces. Oil and oil by-products are not a recommended method to control road dust.
- Use wheel washes at quarries, ready-mix plants, construction sites, and other facilities to prevent track-out of mud, dust, and dirt on to public road.
- Regularly clean road surfaces within the construction sites to remove accumulated fine material, and regularly clean transportation vehicles.
- Cover open bodied trucks handling sand, gravel, or earth.
- Minimize smoke from diesel engines by regular and proper maintenance, by ensuring that the engine, injection system and air cleaners are in good condition.

### **2.2.5. Hazardous and Toxic Materials**

Toxic and deleterious wastes resulting from the Contractor's activities require special attention to forestall their introduction into the natural environment which could result in harm to people, aquatic life, or natural growth of the area. Accordingly, the Contractor shall:

- Train workers regarding the handling of hazardous materials.
- Label using easily understandable symbols, and provide material safety data sheets, for



chemical substances and mixtures according to the Globally Harmonized System (GHS) of classification and labelling of chemicals.

- Store hazardous materials as per the statutory provisions of the Manufactures, Storage, and Import of Hazardous Chemicals Rules (1989).
- Provide adequate secondary containment for fuel storage tanks and for the temporary storage of other fluids such as lubricating oils and hydraulic fluids.
- Use impervious surfaces for refueling areas and other fluid transfer areas.
- Train workers on the correct transfer and handling of fuels and chemicals and the response to spills.
- Provide portable spill containment and cleanup equipment on site and training in the equipment deployment.
- Deposit or discharge toxic liquids, chemicals, fuels, lubricants, and bitumen into containers for salvage or subsequent removal to off-site locations.
- Treat hazardous waste separately from other waste.
- Avoid the storage or handling of toxic liquid adjacent to or draining into drainage facilities.
- Keep absorbent materials or compounds on Site in sufficient quantities corresponding to the extent of possible spills.
- Ensure adequate primary treatment of sanitation effluents and installing septic tanks away from village watering points.

#### **2.2.6. Area Signage**

The Contractor shall:

- Appropriately mark hazardous areas.
- Install warning signs.
- Ensure that signage is in accordance with international standards and is well known to, and easily understood by workers, visitors, and the public as appropriate.
- Demarcate work sites with safety tape, fencing or barricades, as appropriate, to prevent unauthorized access to the construction sites
- Safeguard public safety by covering holes and by installing guardrails along temporary pathways.
- Health and Safety.
- Contractors will collaborate with other contractors in applying health and safety requirements, when workers from more than one contractor are working together in one location, without prejudice to the responsibility of each party for the health and safety of its own workers.

#### **2.2.7. Severe Weather and Facility Shutdown**

The Contractor shall:

- Design and build workplace structures to withstand the expected elements for the region and designate an area designated for safe refuge, if appropriate.
- Develop Standard Operating Procedures (SOPs) for project or process shutdown, including an evacuation plan.

**2.2.8. Lavatories and Showers.**

The Contractor shall:

- Provide adequate lavatory facilities (toilets and washing areas) for the number of people expected to work at the construction sites, and make allowances for segregated facilities, or for indicating whether the toilet facility is “In Use” or “Vacant”.
- Provide toilet facilities with adequate supplies of hot and cold running water, soap, and hand drying devices.
- Where workers may be exposed to substances poisonous by ingestion and skin contamination may occur, provide facilities for showering and changing into and out of street and work clothes.

**2.2.9. Potable Water Supply**

The Contractor shall:

- Provide adequate supplies of potable drinking water from a fountain with a sanitary means of collecting the water for the purposes of drinking.
- Ensure that water supplied to areas of food preparation or for the purpose of personal hygiene (washing or bathing) meets drinking water quality standards.

**2.2.10. Clean Eating Area**

The Contractor shall:

- Where there is potential for exposure to substances poisonous by ingestion, make suitable arrangements to provide clean eating areas where workers are not exposed to the hazardous or noxious substances.

**2.2.11. Noise**

The Contractor shall institute appropriate measures to reduce the exposure of workers to construction noise, including but not limited to:

- Avoid exposure to a noise level greater than 85 dB(A) for a duration of more than 8 hours per day without hearing protection. In addition, no unprotected ear should be exposed to a peak sound pressure level (instantaneous) of more than 140 dB(C).
- Enforce the use of hearing protection should be enforced actively when the equivalent sound level over 8 hours reaches 85 dB(A), the peak sound levels reach 140 dB(C), or the average maximum sound level reaches 110 dB(A).
- Provide hearing protective devices capable of reducing sound levels at the ear to at most 85 dB(A).
- Reduce the “allowed” exposure period or duration by 50 percent for every 3 dB(A) increase in more than 85 dB(A).
- Perform periodic medical hearing checks on workers exposed to high noise levels.
- Rotate staff to limit individual exposure to high levels.
- Install practical acoustical attenuation on construction equipment, such as mufflers.
- Use silenced air compressors and power generators.
- Keep all machinery in good condition.
- Install exhaust silencing equipment on bulldozers, compactors, crane, dump trucks, excavators, graders, loaders, scrapers, and shovels.
- Post signs in all areas where the sound pressure level exceeds 85 dB(A).
- Shut down equipment when not directly in use.
- Provide advance notice to occupants if an activity involving high level impact noise is near

buildings.

#### **2.2.12. Old asbestos waste**

The contractor shall apply all the required measures to protect the workers and the surrounding communities from the hazards associated with the old asbestos waste, including but not limited to the following:

- Treat the waste contaminated with asbestos safely in collection, transportation, and proper disposal in the authorized site to prevent spreading into the air.
- Providing the containers to use for isolating the asbestos material, the signs to install in the site and the criteria for choosing the location in which to bury the asbestos are available for the disposal.
- Ensure that the equipment used for and next to the Asbestos Cement Material (ACM) is washed after use.
- Ensure that the resting areas and the eating facilities are clear from any potential contamination from asbestos.
- Provide adequate washing facilities.
- Ensure that the PPE provided to the workers on site includes disposable coveralls, safety goggles, gloves, and footwear.
- Ensure that a local exhaust ventilation system (LEV) that draws in airborne asbestos is in place when cutting (ACM).
- Ensure that the appropriate filter is installed in the LEV to capture the airborne asbestos before releasing to the environment. The filters should also be treated as a hazardous waste for disposal.
- Ensure that training that is fit for purpose is delivered to the workers to enhance their awareness of the health and safety risks when working with asbestos, to inform them on the method of work and on the control measures to have in place.
- Excavated contaminated soil to be directly placed into the truck and cover it and transport it while it still wet to minimize its effects
- Contaminated soil and damaged asbestos materials and pipes should be buried to prevent spreading into the air.
- Arrangements in the disposal area should be done to ensure it is done properly and documented.
- Proper masks should be worn by all workers and supervisors in the working area. Respirators must be equipped with HEPA filtered cartridges (color coded purple) or an N-100, P-100 or R-100 NIOSH rating.

#### **2.2.13. Painting**

The contractor shall apply all the required measures to protect the workers and the surrounding communities from the hazards associated with painting works including the hazards resulting from use of lead containing paint, including but not limited to the following:

- Provide workers with specialized training and provided with, and wear, appropriate PPE (gloves, apron, splash suits, face shield or goggles, etc.).
- Ensure that the air is renewed, and ventilation are continuous inside the workstation.
- Apply working shift time with minimum time for every worker.
- Ensure that emergency showers are close to the working site.
- Ensure availability of the first aid box; and
- Ensure not procure or use paints containing lead.

**2.2.14. Personal Protective Equipment (PPE)**

The Contractor shall:

- Identify and provide at no cost appropriate PPE to workers, the workers of subcontractors, as well as to visitors, which gives adequate protection without incurring unnecessary inconvenience to the individual.
- Ensure that the use of PPE is compulsory.
- Provide sufficient training in the use, storage, and maintenance of PPE to its workers and workers of its subcontractors.
- Properly maintain PPE, including cleaning when dirty and replacement when damaged or worn out.
- Determine requirements for standard and/or task-specific PPE based on of Job specific Safety Analysis (JSA).
- Consider the use of PPE as a last resort when it comes to hazard control and prevention, and always refer to the hierarchy of hazard controls when planning a safety process.

**2.2.15. First Aid and Accidents**

The Contractor shall:

- Ensure that qualified first-aid by qualified personnel is always available. Appropriately equipped first-aid stations should be easily accessible throughout the place of work.
- Provide workers with rescue and first-aid duties with dedicated training so as not to inadvertently aggravate exposures and health hazards to themselves or their co-workers. Training would include the risks of becoming infected with blood-borne pathogens through contact with bodily fluids and tissue.
- Provide eye-wash stations and/or emergency showers close to all workstations where immediate flushing with water is the recommended first-aid response.
- Provide dedicated and appropriately equipped first-aid room(s) where the scale of work or the type of activity being carried out so requires.
- Equip first aid stations and rooms with gloves, gowns, and masks for protection against direct contact with blood and other body fluids.
- Make widely available written emergency procedures for dealing with cases of trauma or serious illness, including procedures for transferring patient care to an appropriate medical facility.
- Immediately report all accidental occurrences with serious accident potential such as major equipment failures, contact with high-voltage lines, exposure to hazardous materials, slides, or cave-ins to UNICEF.
- Immediately investigate any serious or fatal injury or disease caused by the progress of work by the Contractor and submit a comprehensive report to UNICEF.

**2.2.16. Communicable Diseases**

Recognizing that no single measure is likely to be effective in the long term, the Contractor shall implement a combination of behavioral and environmental modifications to mitigate communicable diseases:

- Conduct Information, Education and Consultation Communication (IEC) campaigns, at least every other month, addressed to all construction sites staff (including all the Contractor's employees, all subcontractors of any tier, consultants' employees working on the site, and

truck drivers and crew making deliveries to the site for Works and Services executed under the Contract, concerning the risks, dangers and impact, and appropriate avoidance behavior of communicable diseases.

- Provide for active screening, diagnosis, counselling and referral of workers to a dedicated national STD and HIV/AIDS program, (unless otherwise agreed) for all Site staff and labor.
- Provide male or female condoms to all Site staff and workers, as appropriate.
- Provide treatment through standard case management in on-site or community health care facilities.
- Ensure ready access to medical treatment, confidentiality and appropriate care, particularly with respect to migrant workers.
- Promote collaboration with local authorities to enhance access of workers families and the community to public health services and ensure the immunization of workers against common and locally prevalent diseases.
- Prevent illness in immediate local communities by:
  - Implementing an information strategy to reinforce person-to-person counselling addressing systemic factors that can influence individual behavior as well as promoting individual protection, and protecting others from infection, by encouraging condom use
  - Conducting immunization programs for workers in local communities to improve health and guard against infection
  - Providing health services

#### **2.2.17. Vector-Borne Diseases**

Reducing the impact of vector-borne disease on the long-term health of workers is best accomplished by implementing diverse interventions aimed at eliminating the factors that lead to disease. The Contractor, in close collaboration with community health authorities, shall implement an integrated control strategy for mosquito and other arthropod-borne diseases that includes the following measures:

- Prevent of larval and adult propagation through sanitary improvements and elimination of breeding habitats close to human settlements
- Eliminate unusable impounded water
- Increase water velocity in natural and artificial channels
- Consider the application of residual insecticide to dormitory walls
- Implement integrated vector control programs
- Promote the use of repellents, clothing, netting, and other barriers to prevent insect bites
- Use chemoprophylaxis drugs by non-immune workers and collaborating with public health officials to help eradicate disease reservoirs
- Monitor and treat circulating and migrating populations to prevent disease reservoir spread
- Collaborate and exchange in-kind services with other control programs in the project area to maximize beneficial effects
- Educate project personnel and area residents on risks, prevention, and available treatment
- Monitor communities during high-risk seasons to detect and treat cases
- Distribute appropriate education materials
- Follow safety guidelines for the storage, transport, and distribution of pesticides to minimize the potential for misuse, spills, and accidental human exposure

### 2.2.18. Road safety and Traffic Safety

The Contractor shall ensure traffic safety by all project personnel during displacement to and from the workplace, and during the operation of project equipment on private or public roads. The Contractor shall adopt best transport safety practices across all aspects of project operations with the goal of preventing traffic accidents and minimizing injuries suffered by project personnel and the public, including:

- Emphasize safety aspects among drivers
- Improve driving skills and requiring licensing of drivers
- Institute defensive driving training for all drivers prior to starting their job
- Adopt limits for trip duration and arranging driver rosters to avoid overtiredness
- Avoid dangerous routes and times of day to reduce the risk of accidents
- Use speed control devices (governors) on trucks, and remote monitoring of driver actions
- Require that drivers and co-passengers wear seatbelts, and duly sanction defaulters.
- Regularly maintain vehicles and use manufacturer approved parts to minimize potentially serious accidents caused by equipment malfunction or premature failure.
- Where the project may contribute to significant changes in traffic along existing roads the Contractor shall:
  - Commence activities that affect public motorways and highways, only after all traffic safety measures necessitated by the activities are fully operational.
  - Arrange diversions for providing alternative routes for transport and/or pedestrians
  - Minimize pedestrian interaction with construction vehicles, particularly at crossing points to schools, markets, and any animal crossing points of significance, through appropriate signage, engineered footpaths or traffic slowing devices.
  - Organize meaningful road accident awareness events at all roadside schools and communities within 150 meters of the road centerline, covering safe road crossing, road accident hazards from weather conditions and vehicle roadworthiness, overloading and driver alertness, dangers posed by parked and broken-down vehicles, etc.
  - Collaborate with local communities and responsible authorities to improve signage, visibility and overall safety of roads, particularly along stretches located near schools or other locations where children may be present.
  - Collaborate with local communities on education about traffic and pedestrian safety (e.g., school education campaigns).
  - Coordinate with emergency responders to ensure that appropriate first aid is provided to all affected persons in the event of accidents.
  - Use locally sourced materials, whenever possible, to minimize transport distances, and locate associated facilities such as worker camps close to project sites.
  - Employ safe traffic control measures, including road signs, traffic cones, removable barriers, and flag persons to warn of dangerous conditions.
  - Avoid indirect damage to existing cultural heritage, such as affecting masonry through vibration

### 2.2.19. Emergencies

The Contractor shall establish and maintain an emergency preparedness and response system, in collaboration with appropriate and relevant third parties including to cover: (i) the contingencies that could affect personnel and facilities of the project to be financed; (ii) the need to protect the health and safety of project workers; (iii) the need to protect the health and safety of the Affected Communities. The emergency preparedness and response system shall include:

- Identification of the emergency scenarios
- Specific emergency response procedures
- Training of emergency response teams
- Emergency contacts and communication systems/protocols (including communication with Affected Communities when necessary)
- Procedures for interaction with government authorities (emergency, health, environmental authorities)
- Permanently stationed emergency equipment and facilities (e.g., first aid stations, firefighting equipment, spill response equipment, personal protection equipment for the emergency response teams)
- Protocols for the use of the emergency equipment and facilities
- Clear identification of evacuation routes and muster points
- Emergency drills and their periodicity based on assigned emergency levels or tiers
- Decontamination procedures and means to proceed with urgent remedial measures to contain, limit and reduce pollution within the physical boundaries of the project property and assets to the extent possible.

#### **2.2.20. Stakeholder Engagement**

As part of the overall Project Stakeholder Engagement<sup>1</sup>, the Contractor will undertake a process of stakeholder engagement with representative persons and communities directly affected by the activities it undertakes, including, if necessary, the public disclosure of its ESMP. The Contractor shall also maintain throughout the Project good relations with local communities and will give these communities prior notice of plans and schedules as they might affect local people.

#### **2.2.21. Labor Force Management**

Labor Conditions, The Contractor shall:

- Implement the measures and commitments defined in the Project Labor Management Procedures.
- Provide all workers with terms and conditions that comply with Afghanistan Labor Legislation, and applicable International Labor Organization conventions on workplace conditions.
- Put in place workplace processes for project workers to report work situations that they believe are not safe or healthy, and to remove themselves from a work situation which they have reasonable justification to believe presents an imminent and serious danger to their life or health. Project workers who remove themselves from such situations will not be required to return to work until necessary remedial action to correct the situation has been taken. Project workers will not be retaliated against or otherwise subject to reprisal or negative action for such reporting or removal.
- Avoid all forms of forced or compulsory labor, i.e., all work or service which is exacted from any person under the threat of a penalty and for which the person has not offered himself or herself voluntarily.

#### **2.2.22. Insurance**

The Contractor shall:

- Protect the health of workers involved in onsite activities, as indicated in Afghanistan Labor legislation

---

<sup>1</sup> The overall process of stakeholder engagement is described in the Project Stakeholder Engagement Plan (SEP)

- Compensate any employee or community for death or injury

### 2.2.23. Grievance Mechanism for Workers

The Contractor shall put in place a Grievance Redress Mechanism (GRM) for its workers and the workers of its subcontractors that is proportionate to its workforce. The GRM for workers shall be distinct from the Project level Grievance Mechanism for affected individuals and communities, and shall adhere to the following principles:

- **Provision of information:** All workers should be informed about the grievance mechanism at the time they are hired, and details about how it operates should be easily available, for example, included in worker documentation or on notice boards.
- **Transparency of the process:** Workers must know to whom they can turn in the event of a grievance and the support and sources of advice that are available to them. All line and senior managers must be familiar with their organization's grievance procedure.
- **Keeping it up to date:** The process should be regularly reviewed and kept up to date, for example, by referencing any new statutory guidelines, changes in contracts or representation.
- **Confidentiality:** The process should ensure that a complaint is dealt with confidentially. While procedures may specify that complaints should first be made to the workers' line manager, there should also be the option of raising a grievance first with an alternative manager, for example, a human resource (personnel) manager.
- **Non-retribution:** Procedures should guarantee that any worker raising a complaint will not be subject to any reprisal.
- **Reasonable timescales:** Procedures should allow for time to investigate grievances fully but should aim for swift resolutions. The longer a grievance is allowed to continue, the harder it can be for both sides to get back to normal afterwards. Time limits should be set for each stage of the process, for example, a maximum time between a grievance being raised and the setting up of a meeting to investigate it.
- **Right of appeal:** A worker should have the right to appeal to the World Bank or national courts if he or she is not happy with the initial finding.
- **Right to be accompanied:** In any meetings or hearings, the worker should have the right to be accompanied by a colleague, friend or union representative.
- **Keeping records:** Written records should be kept at all stages. The initial complaint should be in writing, if possible, along with the response, notes of any meetings and the findings and the reasons for the findings. Any records on SEA shall be registered separately and under the strictest confidentiality.
- **Relationship with collective agreements:** Grievance procedures should be consistent with any collective agreements.
- **Relationship with regulation:** Grievance processes should be compliant with the national employment code.

### 2.2.24. Protection from Sexual Exploitation and Abuse

The Contractor shall:

- Provide repeated training and awareness raising to the workforce about refraining from unacceptable conduct toward local community members, specifically women and children
- Inform workers about national laws that make sexual harassment and gender-based violence a punishable offence which is prosecuted
- Prohibit its employees from exchanging any money, goods, services, or other things of



value, for sexual favors or activities, or from engaging any sexual activities that are exploitive or degrading to any person.

- Develop a system to capture gender-based violence, sexual exploitation and workplace sexual harassment related complaints/issues.
- Adopt a policy to cooperate with law enforcement agencies in investigating complaints about gender-based violence.

#### 2.2.25. Protection from Child Labor

The Contractor shall:

- Verify that workers are older than 18 when hiring
- Exclude all persons under the age of 18.
- Review and retain copies of verifiable documentation concerning the age of workers
- Comply with all relevant local legislation, including labor laws in relation to child labor and World Bank’s safeguard policies on child labor and minimum age.

### 3 Contractor Environmental and Social Reporting

The Implementing Partners (NGO) shall monitor, keep records and report to UNICEF on the following environmental and social issues:

- **Incident and Accident:** The Implementing Partners (NGO) shall report major work-related incidents, accidents, or loss of life to UNICEF or the relevant Implementing Partner within 48 hours of their occurrence. That include hours worked, lost time injury (LTI), lost workdays, recordable incidents and corresponding Root Cause Analysis (lost time incidents, medical treatment cases), first aid cases, high potential near misses, and remedial and preventive activities required (for example, revised job safety analysis, new or different equipment, skills training, and so forth).
- **Environmental Incidents and Near Misses:** Environmental incidents and high potential near misses and how they have been addressed, what is outstanding, and lessons learned.
- **ESHS Requirements:** Noncompliance incidents with permits and national law (legal noncompliance), project commitments, or other ESHS requirements.
- **ESHS Inspections and Audits:** By the UNICEF, Implementing Partners (NGO), and its contractor, or others—to include date, inspector or auditor name, sites visited, and records reviewed, major findings, and actions taken.
- **Training and Capacity Building:** Training on ESHS issues including dates, number of trainees, and topics. As well as list of workers at each site, confirmation of ESHS training, indication of origin (expatriate, local, nonlocal nationals), gender, age with evidence that no child labor is involved, and skill level (unskilled, skilled, supervisory, professional, management).
- **School’s Footprint Management:** details of any work outside boundaries or major off-site impacts caused by ongoing construction—to include date, location, impacts, and actions taken.
- **External Stakeholder Engagement:** Highlights, including formal and informal meetings, and information disclosure and dissemination—to include a breakdown of women and men consulted and themes coming from various stakeholder groups, including vulnerable groups (e.g., disabled, elderly, children, etc.).
- **Details of any Security Risks:** Details of risks the Implementing Partners (NGO) and Contractor may be exposed to while performing its work—the threats may come from third parties external to the project.
- **Worker Grievance Management:** Details including occurrence date, grievance, and date

submitted; actions taken and dates; resolution (if any) and date; and follow-up yet to be taken grievances listed should include those received since the preceding report and those that were unresolved at the time of that report.

- **External Stakeholder Grievances Management:** Grievance and date submitted, action(s) taken and date(s), resolution (if any) and date, and follow-up yet to be taken grievances listed should include those received since the preceding report and those that were unresolved at the time of that report. Grievance data should be gender disaggregated.
- **Deficiency and Performance Management:** Actions taken in response to previous notices of deficiency or observations regarding ESHS performance and/or plans for actions to be taken should continue to be reported to UNICEF until it determines the issue is resolved satisfactorily.

## United Nations Children Fund (UNICEF)

### Code of Conduct

Date [31-08-2023]

Company Name:

Project Name:

Contract Number:

Project Location:

Contact Information: (Phone and Email)

Prepared By: Name and Position

### CODE OF CONDUCT FOR CONTRACTOR'S PERSONNEL

We the Contractor [enter name of Contractor] have signed a contract with UNICEF for [enter description of the activities]. These activities will be carried out at [enter the Site and other locations where the activities will be carried out]. Our contract requires us to implement measures to address environmental and social risks related to the activities, including the risks of sexual exploitation and assault and gender-based violence.

This Code of Conduct is part of our measures to deal with environmental and social risks related to the activities. It applies to all our staff, including laborers and other employees at the at all the places where the activities are being carried out. It also applies to the personnel of every subcontractor and any other personnel assisting us in the execution of the activities. All such persons are referred to as "Contractor's Personnel" and are subject to this Code of Conduct.

***This Code of Conduct identifies the behavior that we require from all Contractor's Personnel.*** Our workplace is an environment where unsafe, offensive, abusive, or violent behavior will not be tolerated and where all persons should feel comfortable raising issues or concerns without fear of retaliation.

#### Required Conduct

Contractor's Personnel shall:

- Carry out his/her duties competently and diligently.
- Comply with this Code of Conduct and all applicable laws, regulations and other requirements, including requirements to protect the health, safety and well-being of other Contractor's Personnel and any other person.
- Maintain a safe working environment including by:
  - Ensuring that workplaces, machinery, equipment and processes under each person's control are safe and without risk to health.
  - Wearing required personal protective equipment.
  - Using appropriate measures relating to chemical, physical and biological substances and agents; and
  - Following applicable emergency operating procedures.
- Report work situations that he/she believes are not safe or healthy and remove himself/herself from a work situation which he/she reasonably believes presents an imminent and serious danger to his/her life or health.
- Treat other people with respect, and not discriminate against specific groups such as women, people with disabilities, migrant workers or children.
- Not engage in any form of sexual harassment including unwelcome sexual advances, requests for sexual favors, and other unwanted verbal or physical conduct of a sexual nature with other Contractor's or Employer's Personnel.
- Not engage in Sexual Exploitation, which means any actual or attempted abuse of position of vulnerability, differential power or trust, for sexual purposes, including, but not limited to, profiting monetarily, socially or politically from the sexual exploitation of another. In Bank financed projects, sexual exploitation occurs when access to or benefit from Bank financed Goods, Works, Consulting or Non-consulting services is used to extract sexual gain.
- Not engage in Sexual Assault, which means sexual activity with another person who does not consent. It is a violation of bodily integrity and sexual autonomy and is broader than narrower conceptions of "rape", especially because (a) it may be committed by other means than force or violence, and (b) it does not necessarily entail penetration.
- Not engage in any form of sexual activity with individuals under the age of 18, except in case of

- pre-existing marriage.
- Complete relevant training courses that will be provided related to the environmental and social aspects of the Contract, including on health and safety matters, and Sexual Exploitation and Assault (SEA).
- Report violations of this Code of Conduct; and
- Not retaliate against any person who reports violations of this Code of Conduct, whether to us or the Employer, or who makes use of the Grievance mechanism for Contractor’s Personnel or the project’s Grievance Mechanism.

**Raising Concerns**

If any person observes behavior that he/she believes may represent a violation of this Code of Conduct, or that otherwise concerns him/her, he/she should raise the issue promptly. This can be done in either of the following ways:

1. Contacting the Individual designated by the Contractor [enter name of Contact]
2. In writing at this address [ ]
3. By telephone at [ ]
4. In person at [ ]
5. Calling [ ] to reach the Contractor’s hotline and leave a message (if available)

The person’s identity will be kept confidential, unless reporting of allegations is mandated by the country law. Anonymous complaints or allegations may also be submitted and will be given all due and appropriate consideration. We take seriously all reports of possible misconduct and will investigate and take appropriate action. We will provide warm referrals to service providers that may help support the person who experienced the alleged incident, as appropriate. There will be no retaliation against any person who raises a concern in good faith about any behavior prohibited by this Code of Conduct. Such retaliation would be a violation of this Code of Conduct.

**Consequences of Violating the Code of Conduct**

Any violation of this Code of Conduct by Contractor’s Personnel may result in serious consequences, up to and including termination and possible referral to legal authorities.

**For Contractor’s Personnel**

I have received a copy of this Code of Conduct written in a language that I comprehend. I understand that if I have any questions about this Code of Conduct, I can contact [enter name of Contractor’s contact person with relevant experience in handling gender-based violence] requesting an explanation.

1. Name of Contractor’s Personnel: [insert name]
2. Signature: \_\_\_\_\_
3. Date: (day month year): \_\_\_\_\_
4. Countersignature of authorized representative of the Contractor:
5. Signature: \_\_\_\_\_
6. Date: (day month year): \_\_\_\_\_

A copy of the code shall be displayed in a location easily accessible to the community and project affected people. It shall be provided in languages comprehensible to the local community, Contractor’s personnel (including sub-contractors and day workers) and affected persons.

## United Nations Children Fund (UNICEF)

### Training and Capacity Building Plan

Date [31-08-2023]

Company Name:

Project Name:

Contract Number:

Project Location:

Contact Information: (Phone and Email)

Prepared By: Name and Position

**Introduction**

Please describe your training and capacity building plan and relevant employees and workers required to be sensitized on Environmental and Social Safeguards aspects including Safety, Security, Traffic incident and accident, occupational health and safety, community health and safety, emergency response procedures, UNICEF Grievance Mechanism, Gender Based Violence, Sexual Exploitation and Abuse, Sexual Harassment, and stakeholder consultation.

**Roles and Responsibilities**

Please describe the responsible person roles and responsibilities within your organization to deliver the training module based on the project scope of work, risks and impact and mitigation measures during the transportation and installation of the HPTs.

**Target Group/Person**

Please describe the target group and person which required to receive an orientation on the above-mentioned subjects like skilled and unskilled workers, drivers, project managers and coordinator.

**Training Plan and Modules**

Please describe the training module, target groups/person, timeframe in the below table based on the project activities and their responsibilities.

No	Training Module	Training Contents	Target Group	Timeframe

**United Nations Children Fund (UNICEF)**

**Occupational Health and Safety (OHS) Management Plan**

Date [31-08-2023]

Company Name:

Project Name:

Contract Number:

Project Location:

Contact Information: (Phone and Email)

Prepared By: Name and Position



**Requirement**

High Performance Tent Partners are required to keep a logbook of incident/accident at their central office and record and report all the incidents within 24 hours.

**Company Organization and Personnel**

Please kindly describe your organization structure, as well as who will be responsible for coordination, management, implementation, monitoring, reporting of the Occupational Health and Safety (OHS) plan implementation.

**Roles and Responsibilities**

Please describe the roles and responsibilities of your manager/staff to implement the OHS plan during the project implementation. For example, the project manager will be responsible for coordination and management of the OHS implementation. Please use the below table:

No	Name and Position	Roles and Responsibilities	Contact Information

**Training and Capacity Building**

Please describe your training and capacity building plan to project workers on Occupation Health and Safety (OHS) measures. Please use the table below.

OHS Capacity Building and Training Plan

No	Training Module	Training Contents	Target Group	Timeframe
1				
2				
3				
4				
5				

**Personnel Protective Equipment (PPEs)**

Please describe and list all Personnel Protective Equipment (PPEs) for the project worker which will be used during HPT’s transportation and installation. Please use the below table:

List of Personnel Protective Equipment (PPEs)

No	Items	Description

**United Nations Children Fund (UNICEF)**

**Traffic Management Plan (TMP)**

Date [31-08-2023]

Company Name:

Project Name:

Contract Number:

Project Location:

Contact Information: (Phone and Email)

Prepared By: Name and Position

**Introduction**

Please describe the road safety and traffic safety measures to be carried out during the transportation of the HPTs by the project worker. Which include the safety practices, measures to prevent traffic incidents and accidents, driving skills and license, training, speed control device (if applicable), maintain vehicles and use of manufacturer.

**Roles and Responsibilities**

Please describe the responsible person roles and responsibilities within your organization to planning, manage, coordinate, train, hazard identification, control, monitor, and supervise the traffic management plan and mitigation measures implementation. Please use the below summarize table

No	Name and Position	Responsibilities	Contact Information

**Emergency Response and Reporting of Hazards**

Please describe the communication strategy and contact details for emergencies, which include the local emergency contact detail, internal reporting mechanism, medical services, first aid kit, and so on.

**Compensation to Affected Worker or Community**

Please describe the compensation to the affected worker and community members during the transportation and installation based on National Labor law and regulation and other applicable governmental law and legislation.

**Training and Capacity Building**

Please describe the training will be deliver to drivers and project worker on traffic management plan, coordination, road safety roles, personnel protective equipment’s, reporting, types of hazards and emergency procedures during the transportation of the HPTs.

No	Training Module	Training Contents	Target Group	Timeframe
1				
2				
3				
4				
5				

**United Nations Children Fund (UNICEF)**

**Traffic Management Plan (TMP)**

Date [31-08-2023]

Company Name:

Project Name:

Contract Number:

Project Location:

Contact Information: (Phone and Email)

Prepared By: Name and Position

**Introduction**

Please describe the procedure to be followed for emergency and incident reporting and management. As well as describe the types of hazards which will have potential impact on the project implementation like security, natural disaster, traffic accident and so on.

**Roles and Responsibilities**

Please describe the roles and responsibilities of your staff in implementing the EPR plan during the project implementation. For example, the project manager will be responsible for coordination, reporting, communication, and management of the emergency. Please use the below table:

No	Name and Position	Roles and Responsibilities	Contact Information

**Emergency Response Procedure**

Please describe your emergency response procedures for all types of hazards like medical emergency, personnel injuries, natural disaster, traffic accident and so on.

**Mitigation Measures**

Please describe the mitigation measure to avoid, mitigate and manage the risks and impact in emergency during the transportation and installation of HPTs.

**Internal Reporting Procedures**

Please describe your internal reporting procedures on emergency, including:

- a. Please describe the call number and person responsible details?
- b. Who will be responsible for the project site and office?
- c. Who will coordinate with relevant authorities?
- d. Who will be in charge of managing the situation?

**External Reporting Procedures**

Please describe your external reporting procedures on emergency, including:

- a. Who will be responsible for coordinating with relevant authorities?
- b. What are the contact details for outside agencies (Police, Fire, and medical services)?
- c. Who will be responsible for communicating with UNICEF?

No	Name and Position	Location/Responsibilities	Contact Information
		Internal	
		External	
		UNICEF	

**Training and Capacity Building**

Please describe the training that will be delivered to project workers on Emergency management, response procedures, coordination, reporting, and types of hazards during the transportation and installation of HPTs.

No	Training Module	Training Contents	Target Group	Timeframe
1				
2				

3				
4				
5				

**Compensation to Affected Worker and Community**

Please describe the compensation to the affected worker and community members during the transportation and installation of HPTs based on National Labor law and regulation and other applicable governmental law and legislation.

**Incident Reporting Logbook**

Beginning Date and Time	
Closing Date and Time	
Location	
Reference	
Is this incident OHS/CHS risk related	Yes No
Reason of the incident	
Nature of the operations affected	
Description of the incident	
Subsequent actions by HPT Partner	
Comments and Recommendations on this issue	

# UNITE PRICE CONTRACT

# WAW/KBL/RFQ-0332

BETWEEN

Women for Afghan Women Organization  
AND

[Contractor Name]

FOR

THE CONSTRUCTION OF

Boundary Wall

IN

Center Paroon, Nuristan province, Afghanistan



# **TABLE OF CONTENTS**

## **CONTRACT DOCUMENT**

<b>SECTION I:</b>	<b>CONTRACT AGREEMENT &amp; CONDITION OF CONTRACT</b>
<b>SECTION II:</b>	<b>FORM OF BID SECURITY, PERFORMANCE BOND &amp;</b>
<b>SECTION III:</b>	<b>PRICED BOQ</b>
<b>SECTION IV:</b>	<b>DRAWINGS</b>

**SECTION I**  
**CONTRACT AGREEMENT & CONDITION OF CONTRACT**

**TABLE OF CONTENT**

Article No	Description	page
1	CONTRACT DOCUMENTS	6
2	DEFINITIONS	6
3	LANGUAGE	7
4	GENERAL OBLIGATIONS OF CONTRACTOR	8
5	GENERAL RIGHTS AND OBLIGATIONS OF Client	9
6	PROJECT AUTHORITY	9
7	CONTRACT PRICE	9
8	SCOPE OF WORKS	10
9	SCHEDULE FOR COMPLETION OF WORKS	11
10	PROGRAM TO BE SUBMITTED	11
11	MATERIAL AND TEST	11
12	SETTING OUT AND POSSESSION OF SITE	11
13	EXTENSION OF TIME FOR COMPLETION	12
14	RATE OF PROGRESS	12
15	DELAYS AND EXTENSION OF TIME	12
16	LIQUIDATED DAMAGES	12
17	INSPECTION	13
18	ACCEPTANCE OF WORK	13
19	SUBSTANTIAL COMPLETION	13
20	TAKING OVER OF SECTIONS OR SEPARABLE PARTS OF THE WORKS	13
21	FINAL COMPLETION, CERTIFICATION AND TAKE OVER	14
22	PAYMENT	14
23	INVOICING INSTRUCTIONS	15
24	ADVANCE PAYMENT GUARANTEE	15
25	PERFORMANCE GUARANTEE	15
26	URGENT REPAIRS	16
27	DEFECTS LIABILITY	16
28	INTEREST ON GUARANTEES	17
29	DEFAULT BY CONTRACTOR	17
30	SITE INSPECTION BY THE CONTRACTOR	17
31	FIRE PREVENTION	18

<b>Article No</b>	<b>Description</b>	<b>page</b>
32	SITE CLEANLINESS	18
33	CARE OF THE ENVIRONMENT	18
34	TRAFFIC AND PROTECTION OF ROADS, PROPERTIES AND SERVICES	18
35	REPORTING AND RECORDS	19
36	LEGAL STATUS	19
37	CONTRACTOR'S PERSONNEL AND SUB-CONTRACTORS	19
38	SOURCE OF INSTRUCTIONS	20
39	CONFIDENTIAL NATURE OF DOCUMENTS	20
40	TITLE TO EQUIPMENT	20
41	INDEMNIFICATION	21
42	CONTRACTOR'S LIABILITIES	21
43	INSURANCE	21
44	FOSSILS, CULTURAL HERITAGE, ETC.	21
45	FORCE MAJEURE	22
46	SUSPENSION BY Client	22
47	TERM AND TERMINATION	22
48	TERMINATION BY Client	23
49	TERMINATION BY THE CONTRACTOR	23
50	ASSIGNMENT	24
51	SETTLEMENT OF DISPUTES	24
52	TAXES AND DUTIES	24
53	OFFICIALS NOT TO BENEFIT	25
54	CORRUPT AND FRAUDULENT PRACTICES	25
55	CHILD LABOUR	25
56	AMENDMENT TO THE CONTRACT	26
57	VARIATIONS	26
58	NOTICES	26
59	EFFECTIVE DATE	27

**THIS CONTRACT  
FOR THE CONSTRUCTION OF**

Boundary wall in Paroon Center, Nuristan Province, Afghanistan

is made on (Insert the date).

**BETWEEN:** Women for Afghan Women Organization, a non-governmental organization registered under the laws of Afghanistan, with its principal office located at Kabul, Afghanistan represented by Mr. Fareed-Ud-Din-Noori, (hereinafter referred to as the "Client")

**AND:** [contractor Name], a construction company registered under the laws of Afghanistan, with its principal office located at [Address] represented by Mr. [Name], being its authorized signatory. (Hereinafter referred to as the "Contractor").

**WHEREAS:**

- A. Client intends to implement these constructions through a standard contracting process, utilizing national contractor capacity. Separate consultant has prepared the design and shall perform the direct site supervision. Cooperation with the local community in the construction process is to be encouraged.
- B. By Invitation to Bids No. WAW/KBL/RFQ-0332 dated [Insert the date]. a copy of which is attached to this Contract, Client invited Bids for provisions of school buildings Construction.
- C. By Bids dated [Insert the date] a copy of which is attached to this contract, the Contractor responded to the Invitation to Bids and represented that it is qualified, capable and willing carry out the construction works as described.
- D. Client wishes to engage the Contractor to undertake the Works all on the terms and conditions set forth in this Contract ; and the Contractor represents that it is qualified, ready, able and willing carry out the Works on the same terms and conditions;

**NOW, THEREFORE,** the Parties hereto mutually agree as follows:

**1. CONTRACT DOCUMENTS**

- 1.1 This document and all annexes hereto, together with the following named documents, which are incorporated herein by reference, constitute the entire Contract (herein referred to as the "Contract" or this "Contract") between Client and the Contractor:
  - a) Annex I : The letter of acceptance
  - b) Annex II : Drawings
  - c) Annex III : Priced Bill of Quantities
  - d) Annex IV : Technical Specifications
  - e) Annex V : Schedule of Completion

- 1.2 The Contract documents are to be taken as complementary of one another, but in case of ambiguities, discrepancies or inconsistencies among them, the Contract shall be interpreted on the basis of the following order of procedure:
  - a) this document.
  - b) Letter of acceptance
  - c) the form of Bids including all attachments.
  - d) Technical Specifications.
  - e) Drawings.
  - f) Bill of Quantities.
- 1.3 The Contract represents the entire and integrated Contract of the Parties with regard to the subject matter hereof and supersedes all prior Contracts, negotiations and representations, either written or oral.
- 1.4 Financial Offer of contractor (BOQ) shall be deemed to form part of specifications

## 2. DEFINITIONS

In this Contract, the following terms shall have the following meaning:

- 2.1 **Employer:** means who employ the Contractor and the legal successors in the title to the Employer but not (except with the consent of the Contractor) any assignee of the Employer.
- 2.2 **Contractor:** means the person or persons, firm or Company whose tender has been accepted by the Employer and includes the Contractor's personal representatives, successors and permitted assigned.
- 2.3 **Contract:** means the Conditions of Contract, Specifications, Methods of Measurement, Drawings, priced Bill of Quantities, Schedules of Rates and Prices, The Letter of Agreement, Addenda and other documents issue thereof.
- 2.4 **Contract Price:** sum named in the Letter of Acceptance, subject to such additions thereto or deductions there from as may be made under the provisions hereinafter contained.
- 2.5 **Constructional Plant:** means all appliances or things or whatsoever nature required in or about the execution or maintenance of the Works but does not include materials or other things intended to form or forming part of the Permanent Works.
- 2.6 **Defects:** Any part of the Works not completed in accordance with this Contract.  
**Defect Liability Period:** Is the period during which the Contractor is responsible for repairing or rectifying defects that appear in the Works. The period commences upon Substantial completion of the Works and runs until the Final Completion. Retention money e.g. 10% of the contractual amount retained as guarantee for the Works shall be return to the contractor by Client upon issuance of the Certificate of Final Completion.
- 2.7 **Drawings:** Drawings of the Works, as included in this Contract, and any additional and modified drawings issued by (or on behalf of) Client, in accordance with this Contract.
- 2.8 **Equipment:** The Contractor's apparatus, machinery and vehicles used in the execution of the Works.

- 2.9 **Laws:** All national legislation, statutes, ordinances and other laws and regulations of any legally constituted public authority.
- 2.10 **Materials:** Things of all kinds intended to form or forming part of the Works, including the supply-only materials.
- 2.11 **Site or Sites:** The place or places where the Works are to be executed and any other place defined as such in the Drawings and Contract Documents.
- 2.12 Specifications:** The Technical Specifications of the Works included in this Contract and any modifications or additions approved by Client.
- 2.13 **Suppliers:** Persons or entities that entered into a Contract directly with the Contractor to supply materials and equipment fabricated specifically for the Works.
- 2.14 **Works:** Permanent and temporary Works required by the Contract Documents as set forth in this Contract.
- 2.15 **Designated Representative:** The officer designated to represent Client, as in the contract. In addition, the stakeholder may use the services of a consultant to supervise the works carried out by the Contractor as provided by Article 2.12 of this Contract.
- 2.16 **The Consultant:** The person or company that has been engaged by stakeholder to carry out the design of the project and assist in the project implementation and the periodical oversight.
- 2.17 **Engineer:** The Engineer is natural or juridical person designated in writing by Client to carry out day to day supervision and inspection of the works.

### **3. LANGUAGE**

The Contract Documents shall be written in English.

### **4. GENERAL OBLIGATIONS OF THE CONTRACTOR**

- 4.1 The Contractor shall, with due care and diligence, execute and maintain the Works and provide all labor, materials, equipment, transportation and other facilities necessary to substantially complete the Works by the Substantial Completion Date, and in accordance with the Contract Documents and the standards defined by this Contract.
- 4.2 The Contractor shall follow any instruction or decision issued by the Engineer, as required for the execution and completion of the works according to this contract.
- 4.3 If instructions are given to the Contractor as described above, such instruction shall be carefully written out in the form designed for the purpose. Instruction should be signed by the Client representative, and by the Contractor's representative. Client and the Contractor shall retain one copy each of the instruction.
- 4.4 **Performance Bond**
- 4.4.1 Advance payment

The Contractor shall cover the advance payment with an unconditional bank guarantee which is cashable on demand means that the bank will pay to Client 100% of the value of the guarantee on demand, without requiring any justification.

Then the value of the advance payment needs to be gradually recovered from subsequent progress payments, until 100%, when the Advance Payment Guarantee can be released back to the contractor.

#### 4.4.2 Performance Bond

The contractor undertakes to enter into a Bond with 7 days after the receipt of the letter of Acceptance for the due and proper performance of the contract and observance of all provisions, covenants, conditions and stipulations there in the sum of 10% of the contract price.

4.5 The Contractor shall take full responsibility for the adequacy, stability and safety of all Site operations and methods of construction and for security of the Site itself, including the security of all Materials stored or used on the Site.

4.6 The Contractor shall submit material samples, and relevant information, in sufficient time for the Client to complete review of samples. Each sample shall be labeled as to origin and intended use in the Works. All materials used in the course of these Works shall be new and proper for their use. No reusable materials coming from the Site shall be used unless permitted by the Client. Other materials shall be stored on Site until the end of the Works. All materials, equipment and products shall be installed in accordance with the written recommendations of the manufacturer.

4.7 When required, the Contractor shall cooperate and share the Site with other contractors and public authorities.

4.8 The Contractor shall take full responsibility for the care of the Works and the materials and plant for incorporation in the Works from the commencement date of the Contract until the issuance of the Certificate of Substantial Completion by Client, and Client taking the facilities into use. Provided that the Contractor shall retain full responsibility for any outstanding part of the Works, materials or plant which the Contractor requires during the period necessary to complete the Defects Liability Period obligations.

### **5. GENERAL RIGHTS AND OBLIGATIONS OF Client**

5.1 Client shall have unlimited access to supervise the Works. Client shall have the right to review the type, quantity and quality of materials and workmanship used in the Works to ensure compliance with the Contract Documents and the standards defined by this Contract.

5.2 Client shall issue all certificates upon satisfaction of conditions necessary for the issuance of such certificates, supply all necessary information and written instructions for the Contractor to carry out the Works properly.

5.3 Further to Article 13 this Contract, Client shall hand over the site(s) to the Contractor within 7 –seven- working days from the Effective Date of this Contract to enable the Contractor to proceed in accordance with this Contract.

5.4 Client shall have the right to issue, and the Contractor shall comply with, additional instructions. Such additional instructions shall complement and/or clarify the Contract Documents and shall have no effect on the definition of the Works, the Prices and/or the Substantial Completion Date(s). Such instructions may take the form of technical specifications, drawings, samples, models or instructions.

## **6. PROJECT AUTHORITY**

- 6.1 Client and the Contractor shall each nominate a Project Authority who shall be responsible for the day-to-day liaison and management of the Contract.

## **7. CONTRACT PRICE**

- 7.1 In full and final consideration of the complete and satisfactory performance of its obligations hereunder, Client shall pay the Contractor a maximum of the following amounts in respect of the completion of the Works ([the "Contract Price"](#)):
- 7.2 The price is not subject to any adjustment or revision because of price or currency fluctuations, the actual costs incurred by the Contractor in the performance of its obligations hereunder or modifications to this Contract or the Contract Documents without a duly signed amendment in accordance with Article 60 of this Contract.

## **8. SCOPE OF WORK**

### **8.1 General Scope of Work**

The contractor shall perform the following work: [Construction of Boundary Wall Mandi Mixed Primary School, Paroon Center, Nuristan Province, Afghanistan.](#)

- [List of specific construction tasks, including but not limited to, site preparation, foundation works, structural works, electrical and plumbing installations, finishing works, also include the supply of all material and manpower etc.]

### **8.2 Specific Scope of Works**

The Scope of Works shall be completed in accordance with the Drawings and as detailed in the Bill of Quantities and Technical Specification. The Scope of Works shall also include, but not be limited to, the following:

- 1) Provide Quality Management System for the assurance of Quality of materials and construction complete with schedule of "hold and instruction points".
- 2) Provide implementation plan using gun chart and/or S-Curve.
- 3) Mobilisation and demobilisation of all equipment, materials and man powers required to complete the Works.
- 4) Construction of temporary site office and provision of all necessary furniture and other office equipment reasonably required for the completion of the Works. The temporary site office shall include space for the Authorised and Designated Representatives for supervision and inspection purposes.
- 5) All necessary temporary works required to provide access to the site, secure storage of materials and to facilitate construction in a safe manner.
- 6) All necessary site preparation works including all other ground preparation works that may be necessary.
- 7) All necessary works for the preparation of the foundations including excavations, shoring and dewatering where required.
- 8) All necessary works, including the supply of materials, to facilitate the construction of the superstructure and roof.



- 9) All necessary works involved with the finishing of the building including, but not limited to, the supply and installation of doors and windows, interior and exterior painting.
- 10) Provision of a sign for the site in accordance with instructions issued by Client, and in Contract with the community.

**The Scope of Works does not include:**

- 1) Landscaping of the site after completion, except that the site shall be handed over in a clean and orderly condition, ready for landscaping by the community.
- 2) All activities must be in accordance to the approved BoQ, specifications, ASTM standard, ACI code.
- 3) All construction activities' quality must be approved by the Client Quality Control/Assurance Team, if any non-conformities are identified, the concerned items shall be replaced after thorough confirmation by Client. The replacement process will be executed in accordance with the specifications and standards outlined in this Agreement, ensuring alignment with the agreed-upon project requirements.

## **9. SCHEDULE FOR COMPLETION OF WORKS**

- 9.1 The construction work shall be entirely completed by [4 months](#) from the "Effective Date" (hereinafter the "Completion Date") in accordance with the terms and conditions of this Contract, including the project schedule (hereinafter "Annex-I- Schedule of Completion") to be submitted by the Contractor to Client within 7 days of the Effective Date for its approval.
- 9.2 A works diary shall be kept at the Site and maintained daily by the Contractor. This diary shall describe all works started and completed each day and shall be checked periodically by Client.

## **10. PROGRAM TO BE SUBMITTED**

- 10.1 The Contractor shall within 7 (seven) days of the date of this Contract submit to Client a program for the execution of the Works. The program should contain all activities required to carry out the Works, and specifically note all critical activities, including critical path, and critical inspection points.
- 10.2 If at any time it should appear that the actual progress of the work does not conform to the program, a revised program shall be submitted, showing modifications necessary to ensure completion on time.
- 10.3 Submission by the Contractor and acceptance by Client of such program or revised program shall not relieve the Contractor of any of their duties or responsibilities under the Contract.

## **11. MATERIAL AND TEST**

- 11.1 Further to the requirements of Article 4.1 & 4.6 of this Contract all materials, plant and workmanship shall be:
  - a.- of the respective kinds described in the Contract; and
  - b.- subjected to tests as detailed in the Technical Specification.
- 11.2 Client may request additional tests at any time. Such tests may be performed on site, at the place of manufacture or at such other place as

may be specified or agreed by Client. The Contractor shall provide all necessary assistance for obtaining the samples for testing and shall provide the samples and carry out the testing at his own cost. Client may at its own discretion take samples and carry out tests in addition to those done by the Contractor.

## **12. SETTING OUT AND POSSESSION OF SITE**

- (a) The Contractor shall be responsible for the accurate setting-out of the Works in accordance with the Drawings, including lines, levels, positions, dimension, alignments, etc. of all parts of the Works.
- (b) Benchmarks shall be established by the Contractor at all sites and shall be available for the setting out. The Contractor shall be responsible for maintaining and protecting the benchmarks at all times.
- (c) If at any time during the execution of the Works errors are found in this setting-out, the Contractor shall, at his own cost, rectify such error to the satisfaction of Client.

## **13. EXTENSION OF TIME FOR COMPLETION**

Should the amount of extra or additional work of any kind or any cause of delay referred to in these Conditions, or exceptional adverse climatic conditions, or other special circumstances of any kind whatsoever which may occur, other than through a default of the Contractor, be such as fairly to entitle the Contractor to an extension of time for the completion of the Works, the Engineer, after due consultation with the Employer, determine the amount of such extension and shall notify the Employer and the Contractor accordingly. Provided that the Engineer is not bound to take into account any extra or additional work or other special circumstances unless the Contractor has within 14 (fourteen) days after such work has been commenced, or such circumstances have arisen, or as soon thereafter as is practicable, submitted to the Engineer full and detailed particulars of any extension of time to which he may consider himself entitled in order that such submission may be investigated at the time.

## **14. RATE OF PROGRESS**

- 14.1 If for any reason, which does not entitle the Contractor to an extension of time as provided by Article 15.1 of this Contract, the rate of progress of the Works or any section of the Works is at any time considered Client to be too slow to comply with the time for completion, the Contractor shall immediately take such steps as are necessary to expedite progress so as to be able to complete the Works on time. The Contractor shall not be entitled to any additional payment for taking such steps.

## **15. DELAYS AND EXTENSION OF TIME**

- 15.1 The Contractor may be entitled to an extension of time in the event of the following:
  - 1) a substantial increase in the amount of work to be done under the Contract.
  - 2) exceptionally adverse climatic conditions; or
  - 3) other special circumstances which may in the Contractor's opinion prevent or hinder the progress of the Works.

- 15.2 The Contractor shall immediately inform Client of the need for extension of time, and within 14 (fourteen) days from the occurrence of the event, provide all necessary details of the occurrence to enable Client to make an assessment of the entitlement. Client may at its sole discretion grant such extension of time as it considers reasonable under the circumstances.

## **16. LIQUIDATED DAMAGES**

- 16.1 The Contractor acknowledges that Client will suffer both financial loss and inconvenience if the construction work is not completed by the Completion Date. The Contractor further acknowledges therefore, that time is of the essence with respect to the Contractor's completing the construction work by the Completion Date. Accordingly, and without prejudice to any other rights and remedies available to Client, for any reason, other than fault or neglect of the Client, or an act of God, in the event the Contractor shall not complete the construction work by the Completion Date, the Contractor agrees to pay to Client as liquidated damages, a sum equivalent to point one percent (0.3 %) per day of delay calculated on the value of the contract until completion of required services, up to a maximum deduction of ten percent (10%) of the Contract Price. Contractor agrees that any amounts owing by it to Client as liquidated damages hereunder may, unless paid within seven (7) days following written demand for same by Client, be deducted from any monies due to the Contractor under this Contract. These liquidated damages shall not relieve the Contractor of his obligations or responsibilities that he may have under the Contract.

## **17. INSPECTION**

- 17.1 Further to the requirements of Article 5.1 of this Contract, Client shall at all times be given access to the site or to any place of fabrication of materials or plant to be supplied under the Contract, in order to inspect and request testing of such materials or plant, and the Contractor shall make arrangements for such tests to be carried out at his own cost.
- 17.2 Any materials or plant found not to be in accordance with the Contract shall be rejected by Client and shall be removed from site immediately.

## **18. ACCEPTANCE OF WORK**

- 18.1 Client shall have a reasonable time after completion of the Works or part of the Works, and before issuance of the Certificate of Substantial Completion, to inspect the Works and to reject and refuse acceptance of Works not conforming to the Contract. Inspection prior to completion of Works does not relieve the Contractor from any of its obligations under the Contract.

## **19. SUBSTANTIAL COMPLETION**

- 19.1 The Works shall be deemed substantially completed when they are completed in accordance with the Contract Documents and the standards defined by this Contract or when they are effectively used for the purpose for which they are intended.
- 19.2 Client shall inspect the Works at the Site on the date they are substantially completed and will issue a certificate of substantial completion by both parties (the "Certificate of Substantial Completion"), provided that the

Works are satisfactory according to the Contract Documents and the standards defined by this Contract. The Certificate of Substantial Completion shall list all Defects that must be remedied by the Contractor prior to a final inspection by Client.

## **20. TAKING OVER OF SECTIONS OR SEPARABLE PARTS OF THE WORKS**

20.1 In accordance with the procedure set out in Article 19 of this Contract, the Contractor may request and Client may agree to issue a Certificate of Substantial Completion in respect of:

1. any substantial part for which a separate time for completion is provided in Article 10 of this Contract; or
2. any substantial part of the Works which has been both completed to the satisfaction of Client and may be occupied or used by Client or the beneficiaries.

20.2 Such Certificate of Substantial Completion for a part of the Works shall not relieve the Contractor of his responsibilities under the Contract, and the Contractor shall be deemed to have undertaken to complete with due expedition any outstanding work and rectification of defects in that part of the Works during the Defects Liability Period as provided in Article 28 of this Contract. A separate Defects Liability Period shall apply for each separate section or separable part taken over in accordance with the above

## **21. FINAL COMPLETION, CERTIFICATION AND TAKE OVER**

21.1 The Work is defined as taken over by Client at the time of the issuance of Certificate of Substantial Completion, as described in Article 19 of this Contract. The issuance of Certificate of Final Completion shall be deemed to be the date of the actual/final completion of the Contract.

21.2 Client shall carry out a final inspection at each Site (the "Final Inspection") 6 (Six) months after the issuance of the Certificate of Substantial Completion for the Site. The Works shall be deemed to be completed when all Defects listed on the Certificate of Substantial Completion, and all Defects that have become apparent after the issuance of the Certificate of Substantial Completion, have been remedied by the Contractor and Client considers the Works to be satisfactory according to the Contract Documents and the standards defined by this Contract. Client shall then issue a Certificate of Final Completion.

21.3 Upon signature of the Certificate of Final Completion at each Site, the Site and Works shall be taken over by Client.

21.4 The condition described in Article 21.3 of this Contract shall be deemed to mean the final taking over of rectified defects and outstanding parts of the Works, as defined in accordance with Article 19.2 of this Contract.

## **22. PAYMENT**

All payments shall be made in in AFN, unless otherwise, stated. Similarly, all payments will be made in AFN through Local banks only.

The Client shall pay the Subcontractor the total amount of [\[Total Contract Amount\]](#) for the completion of the work. Payment shall be made in installments as follows:

<b>Payment schedule for Mandi Mixed Primary School</b>	
<b>First Installment</b>	First Installment: 30% of the total contract value will be released after completion of 40% of practical work in the site as per the BoQ and after confirmation by the site engineer and WAW representative and WAW regional manager.
<b>Second Installment</b>	Second Installment: 30% of the total contract value will be released after completion of 70% of practical work in the site as per the BoQ and after confirmation by the site engineer and WAW representative and WAW regional manager.
<b>Final Installment</b>	Final Installment: 40% of the total contract value will be released after completion of 100% of practical work in the site as per the BoQ and initial handover and after confirmation by the site engineer and WAW representative and WAW regional manager.

**22.4 Money retention:**

UNICEF shall deduct 10% amount from each invoice as Retention Money (RM). The maximum amount of Retention Money so deducted will be 10% of the contract value.

10.2 The RM will be retained with UNICEF as a Security Bond for Defect Liability Period and will be released after successful expiry of 6 months DLP for the renovation works

22.4.1 UNICEF will not pay any interest on the retention money.

22.5 All payments shall be made by Client to the following bank account of the Contractor:

Name of Bank : \_\_\_\_\_  
 Account Number : \_\_\_\_\_  
 Address of Bank : \_\_\_\_\_

**23. INVOICING INSTRUCTIONS**

23.1 Invoices must refer to the Contract and clearly indicate prices for each Contract item number. The Contractor shall submit the original to the following address:

**Women for Afghan Women Organization.**

**Address:**

WAW Main Office, House # 07, In front of Shams London Academy, Taraki Street, Kart-e-Char, Kabul

**24. ADVANCE PAYMENT GUARANTEE Not Applicable**

24.1 The Employer shall pay advance payment to the contractor equivalent to 10 (ten) percent of the Contract Price to be paid no later than 30 (thirty) days after signing of contract, against provision by the contractor of a Bank Guarantee only acceptable to the Employer dominated in Afghanistan in the amount of the advance payment.

24.2 The contractor is to use the advance payment to pay for Equipment, Plant, Material, and mobilization expenses required specifically for execution of the contract. The contract shall demonstrate that the advance payment has been used in this way by supplying copies of invoices or other documents to the Engineer.

24.3 The advance payment will be repaid by deducting proportionate amounts from each payment certificate starting on the first payment certificate. The repayment of advance payment shall end prior to the time when 90 percent of the Contract Price has been certified for payment.

## **25. PERFORMANCE GUARANTEE**

- 25.1 Within 15 days of the Effective Date, the Contractor shall, at its own cost and expense, furnish Client with a Performance Bond in an amount equal to 10% of the Contract Price in a form of bank guarantee only, as shall be approved by Client in the form attached.
- 25.2 The performance bond shall be valid until at least ninety (90) days after the issuance of the Final Acceptance Certificate. If the Contractor fails to deliver such bond within the time limit set forth above, the Contractor agrees that Client shall be entitled to obtain the equivalent percentages amount stated above from the Contractor, including, without limitation, by way of deduction of said amount from any payment due to the Contractor under this Contract.
- 25.3 Client has the right to claim payment on the Performance Guarantee in case of default on the part of the Contractor in performing any part of the Works or in carrying out an instruction issued by Client. In that case Client can cash in the performance guarantee, which should cover the cost of terminating the contract and the cost of hiring a new contractor to come and finish the works.

## **26. URGENT REPAIRS**

- 26.1 If by reason of any accident or failure or other event occurring to, or in connection with the Construction Work or any part thereof during the execution of the Construction Work, any remedial or other work or repair which in the opinion of Client shall be deemed urgently necessary for security, and the Contractor is unable or unwilling at once to do such work or repair, the Contractor will have defaulted on its obligations under this Contract, and, in such case, Client may by its own or other workmen do such work or repair as Client may consider necessary. If the work or repair so done by Client is work which the Contractor was liable to do at his own expense under the Contract, all costs and charges properly incurred by Client shall, on demand, be paid by the Contractor to Client or may be deducted by Client from any monies due or which may become due to the Contractor provided that the Contractor has been notified by Client as soon as practicable after the occurrence of any such emergency.

## **27. DEFECTS LIABILITY**

### **27.1 Definition of Defect Liability Period**

In these Conditions the expression "Defect Liability Period" shall mean the period of recovering defect named in the Appendix to the Tender – 6 (Six) months, calculated from the date of completion of works, certified by the Engineer in accordance with Article 19 hereof, or, in the event of more than one certificate having been issued by the Engineer under the said Article, from the respective dates so certified and in relation to the Period of Maintenance the expression "the Works" shall be construed accordingly.

### **27.2 Execution of Work of Repair, etc.**

To the intent that the Works shall at or as soon as practicable after the expiration of the Period of Maintenance be delivered to the Employer in the condition required by the Contract, fair wear and tear excepted, to the satisfaction of the Engineer, the Contractor shall finish the work, if any, outstanding at the date of completion, as certified under hereof, as Article 19 soon as practicable after such date and shall execute all such work of

repair, amendment, reconstruction, rectification and making good defects, imperfection, shrinkages or other faults as may be required of the Contractor in writing by the Engineer during the Period of Maintenance, or within fourteen days after its expiration, as a result of an inspection made by or on behalf of the Engineer prior to its expiration.

**27.3 Cost of Execution of Work of Repair, etc.**

All such work shall be carried out by the Contractor at his own expense if the necessity thereof shall, in the opinion of the Engineer, be due to the use of materials or workmanship not in accordance with the Contract, or to neglect or failure on the part of the Contractor to comply with any obligation, expressed or implied, on the Contractor's part under the Contract. If, in the opinion of the Engineer, such necessity shall be due to any other cause, the value of such work shall be ascertained and paid for as if it were additional work.

**27.4 Remedy on Contractor's Failure to Carry Out Work Required**

If the Contractor shall fail to do any such work as aforesaid required by the Engineer, the Employer shall be entitled to employ and pay other persons to carry out the same and if such work is work which, in the opinion of the engineer, the Contractor was liable to do at his own expense under the Contract, then all expenses consequent therein or incidental thereto shall be recoverable from the Contractor by the Employer, or may be deducted by the Employer from any monies due or which may become due to the Contractor.

**27.5 Contractor to Search**

The Contractor shall, if required by the Engineer in writing, search under the directions of the Engineer for the cause of any defect, imperfection or fault appearing during the progress of the Works or in the Period of Maintenance. Unless such defect, imperfection or fault shall be one for which the Contractor is liable under the Contract, the cost of the work carried out by the Contractor in searching as aforesaid shall be borne by the Employer. If such defect, imperfection or fault shall be one for which the Contractor is liable as aforesaid, the cost of the work carried out in searching as aforesaid shall be borne by the Contractor and he shall in such case repair, rectify and make good such defect, imperfection or fault at his own expense.

**28. INTEREST ON GUARANTEES**

29.1 Client shall not pay any interest on Guarantees provided in Articles 24 & 25 of this Contract or any other Guarantee provided by the Contractor.

**29. DEFAULT BY CONTRACTOR**

29.1 In case of default on the part of the Contractor in performing any part of the Works or in carrying out an instruction issued by Client within a reasonable time, Client shall be entitled to employ and pay other persons to carry out the same. Costs consequent thereon or incidental thereto shall be deducted by Client from any monies due or to become due to the Contractor.

**30. SITE INSPECTION BY THE CONTRACTOR**

30.1 The Contractor shall have inspected and examined the Site, its surroundings, data on sub-surface and hydrological conditions and

environmental aspects. The Contractor shall be responsible for the correct positioning of the Works and shall rectify any error in the positions, levels, dimensions or alignment of the Works.

- 30.2 The Contractor is required to thoroughly familiarize itself with the conditions on site. This may include geotechnical and other site or environmental investigations as the Contractor deems necessary, at the Contractor's own cost.
- 30.3 For some sites preliminary site surveys and investigations shall be made available to the Contractor. These shall be for information only and are made available without prejudice and shall not constitute any contractual guarantee by Client.
- 30.4 The Contractor shall be deemed to have satisfied himself of the adequacy of his Bids price to cover all his obligations under the Contract.

### **31. FIRE PREVENTION**

- 31.1 The Contractor shall be responsible for fire prevention on the Site where the Works are being performed. Firefighting equipment shall be kept on Site and under the control of the Contractor at all times during the period when Works are taking place on the Site and during rest breaks. The Contractor shall ensure that his employees and sub-contractors can operate the firefighting equipment. All firefighting equipment must be in good working condition. The Contractor's employees and sub-contractors shall carry out any operations requiring exposed flame or welding in a careful and safe manner.

### **32. SITE CLEANLINESS**

- 32.1 The Site shall be kept clean of debris at all times. Progressively and at the end of the Works, the Contractor shall, according to the instruction of Client, clean and keep clean the buildings and the Site.
- 32.2 Upon the issuance of the Certificate of Substantial Completion as provided by Article 19 of this Contract, the Contractor shall clear away and remove from site all equipment, surplus materials, rubbish and temporary works of every kind, and leave the site in a clean and functional condition.

### **33. CARE OF THE ENVIRONMENT**

- 33.1 The Contractor shall ensure that minimal damage occurs to the environment, the vegetation, existing structures and utilities as a result of the Works. The Contractor shall be responsible to remedy damage, other than minimal damage, to the environment, the vegetation, existing structures and utilities at no cost to Client.

#### PSEA Clauses:

Comprehensive Safeguarding Policy is integral to this commitment, addressing critical concerns such as child protection and preventing sexual abuse.

- a. Child Protection: We strictly forbid child labor or exploitation in any form within our operations. This prohibition extends to our supply chain, mandating suppliers to comply with age-appropriate labor practices aligned with international standards.



- 
- b. **Sexual Abuse Prevention:** We uphold a zero-tolerance approach to sexual abuse in our processes. This commitment extends to all involved parties, prioritizing dignity and respect. Our policy emphasizes clear reporting channels for addressing concerns related to sexual abuse, guaranteeing prompt and confidential investigation and resolution.
  - c. **Compliance with Laws and Regulations:** Our Safeguarding Policy underscores compliance with all relevant laws and regulations about child protection, sexual abuse, and other safeguarding issues. We continuously update our practices to align with the latest legal requirements, reflecting our commitment to due diligence and responsible corporate citizenship.
  - d. **Integrity and Fair Dealing:** All activities shall be conducted with integrity, honesty, and fairness, maintaining a transparent and competitive process.
  - e. **Confidentiality Obligations:** Suppliers shall maintain the confidentiality of all proprietary information and data shared during the procurement process and contractual engagement.
  - f. **Environmental Responsibility:** Suppliers are encouraged to adopt environmentally friendly practices and reduce the environmental impact of their operations.
  - g. **Social Responsibility:** Our organization supports suppliers' commitment to fair labor practices, diversity, inclusion, and social responsibility within their operations.

#### Environmental & Social Safeguard Policy

The contractor should be committed to adhere the Client Environmental & Social Safeguard Policy.

This policy encompasses a multifaceted approach to ensuring that our operations consider and mitigate potential adverse environmental and social impacts. Our commitment includes but is not limited to:

1. Conducting thorough environmental impact assessments for all project phases.
2. Implementing measures to prevent and mitigate environmental degradation.
3. Prioritizing the use of sustainable and eco-friendly practices in all project activities.
4. Engaging with local communities to ensure their active participation and benefit from the project.
5. Establishing monitoring mechanisms to track and assess environmental and social impacts continuously.

6. In commitment to promoting the well-being of children and families.
7. Implementing child protection measures to ensure that our activities do not harm or exploit children.
8. Integrating gender-sensitive approaches to promote equality and inclusivity.
9. Collaborating with local communities and relevant stakeholders to address social and cultural considerations.
10. Establishing grievance mechanisms to address concerns and complaints from affected communities.
11. Conducting regular assessments to identify and address any potential social risks associated with our operations.

#### **34. TRAFFIC AND PROTECTION OF ROADS, PROPERTIES AND SERVICES**

- 34.1 The Contractor shall carry out all work in connection with this Contract so as not to interfere unnecessarily or improperly with the convenience of the public and with access to, use and occupation of roads, footpaths, public services or property not in the Contractor's possession.
- 34.2 The Contractor shall use every reasonable means to prevent damage to roads, bridges and services, and shall select routes and limit extraordinary traffic to avoid unnecessary damage or injury.
- 34.3 Where necessary to divert or control traffic, the Contractor shall, in cooperation with traffic control authorities if required, provide all necessary facilities and resources at his own cost.
- 34.4 The Contractor shall be responsible for and shall pay the cost of any strengthening or improvement of routes to the site, in order to facilitate movement to site of equipment, temporary works, materials, etc. This shall apply to all necessary relocation of services.
- 34.5 The above shall also apply to any waterborne traffic required for the Works, in so far as it may affect docks, jetties, sea walls, etc.
- 34.6 The Contractor shall bear all costs and charges for special or temporary permits required in connection with access to site.

#### **35. REPORTING AND RECORDS**

- 35.1 The Contractor shall provide regular reports detailing the progress of the Works, costs incurred and estimate of time and costs to completion. Reports shall be submitted on a monthly basis in a format to be mutually agreed upon by the Parties within ten (10) days after signing of this Contract.
- 35.2 The Contractor shall maintain records and receipts for the purchase of all Materials and remuneration of labor used in the Works and shall make such records and receipts available for inspection by the Designated Representative, upon request.

### **36. LEGAL STATUS**

36.1 The Contractor shall be considered as having the legal status of an independent contractor vis-à-vis Client. The Contractor's personnel and sub-contractors shall not be considered in any respect as being the employees or agents of Client.

### **37. CONTRACTOR'S PERSONNEL AND SUB-CONTRACTORS**

37.1 The Contractor shall be responsible for the professional and technical competence of its employees and shall select, for work under this Contract, reliable individuals who shall perform effectively in the implementation of the Contract, respect the local customs, and conform to a high standard of moral and ethical conduct.

37.2 In the event the Contractor requires the services of sub-contractors, the Contractor shall obtain the prior written approval and clearance of Client for all sub-contractors. The approval of Client of a sub-contractor shall not relieve the Contractor of any of its obligations under this Contract. The terms of any sub-contract shall be subject to and in conformity with the provisions of this Contract.

37.3 The Contractor shall designate and notify Client in writing the name of a Representative on each particular Site or part of the Works.

37.4 Client may request the replacement forthwith of any of the Contractor's employees who is, in the opinion of Client, unsuitable for work on the Contract, whether for misconduct or from incompetence or negligence in his performance, and the contractor shall replace such person as soon as possible.

37.5 The Contractor shall take all possible care to safeguard his employees and any person visiting the Site from danger to life or health and shall issue his employees with appropriate safety protection equipment required by the relevant regulations. Safety rules shall be established for the Site and shall be made readily available to all personnel. All personnel shall receive adequate safety training. Any person found violating safety procedures shall be liable for dismissal from the Site.

37.6 In case of any accident or mishap occurring at Site, the Contractor shall provide a full report of such incidence to Client within one day of the incident occurring, giving probable reasons for the accident and any steps the Contractor shall take to avoid recurrence.

37.7 None of the Works shall be carried on during the night or on locally recognized days of rest without the consent of Client, except when work is unavoidable or absolutely necessary for the protection of life or property, or for the safety of the Works.

### **38 SOURCE OF INSTRUCTIONS**

38.1 The Contractor shall neither seek nor accept instructions from any authority external to Client in connection with the performance of its services under this Contract. The Contractor shall refrain from any action that may adversely affect Client shall fulfill its commitments with the fullest regard to the interests of Client.

**39. CONFIDENTIAL NATURE OF DOCUMENTS**

All maps, drawings, photographs, mosaics, plans, reports, recommendations, estimates, documents and all other data comply by or received by the Contractor under this Contract shall be the property of Client, shall be treated as confidential and shall be delivered only to the Client authorized officials on completion of Works under this Contract.

**40. TITLE TO EQUIPMENT**

40.1 Title to any equipment and supplies which may be furnished by Client shall rest with Client. Any such equipment shall be returned to Client at the conclusion of this Contract or when no longer needed by the Contractor. Such equipment when returned to Client shall be in the same condition as when delivered to the Contractor, subject to normal wear and tear.

**41. INDEMNIFICATION**

41.1 The Contractor shall indemnify, hold and save harmless and defend, at its own expense, Client, its officials, and employees, from and against all suits, claims, demands and liability of any nature or kind, including their costs and expenses, arising out of the acts or omissions of the Contractor or its employees, officers, and sub-contractors in the performance of this Contract. This provision shall extend, inter alia, to claims and liability in the nature of workmen's compensation, product liability and liability arising out of the use of patented inventions or devices, copyrighted material or other intellectual property by the Contractor, its employees, officers, or sub-contractors. The obligations under this Article do not lapse upon termination of this Contract.

**42. CONTRACTOR'S LIABILITIES**

42.1 The Contractor shall be liable for and thereafter provide and maintain insurance against all risks in respect of its property and any equipment used for the execution of this Contract.

42.2 The Contractor shall be liable for and thereafter provide and maintain all appropriate workmen's compensation and liability insurance, or its equivalent, with respect to its employees to cover claims for death, bodily injury or damage to property arising from the execution of this Contract. The Contractor represents that the liability insurance includes sub-contractors.

42.3 The Contractor shall be liable and thereafter provide and maintain liability insurance in an adequate amount to cover third party claims for death or bodily injury, or loss of or damage to property, arising from or in connection with the provision of work under this Contract or the operation of any vehicles, boats, aircraft or other equipment owned or leased by the Contractor, its employees or sub-contractors performing work or services in connection with this Contract.

**43. INSURANCE**

43.1 In addition to the liability upon the Contractor described in Article 43 of this Contract, the Contractor shall insure the Works, together with materials and plants for incorporation in the Works, to the full replacement cost during the time this is in the care of the Contractor.

**44. FOSSILS, CULTURAL HERITAGE, ETC.**

45.1 Any fossils, coins, articles of value or antiquity and structures or things of geological, archaeological or cultural interest discovered on site shall, for the purpose of this Contract, be deemed to be the property of Client. The Contractor shall take all reasonable precautions to prevent removal or damage to any such article or thing, and shall immediately notify Client of such discovery. Client shall, in each case, decide on course of action for dealing with what has been discovered.

**45. FORCE MAJEURE**

45.1 In the event of and as soon as possible after the occurrence of any cause constituting force majeure, the Contractor shall give notice and full particulars in writing to Client of such occurrence or change if the Contractor is thereby rendered unable, wholly or in part, to perform its obligations and meet its responsibilities under this Contract. The Contractor shall also notify Client of any other changes in conditions or the occurrence of any event that interferes or threatens to interfere with its performance of this Contract. On receipt of the notice required under this Article, Client shall take such action as, in its sole discretion, it considers to be appropriate or necessary in the circumstances, including the granting to the Contractor of a reasonable extension of time in which to perform its obligations under this Contract.

45.2 If the Contractor is rendered permanently unable, wholly, or in part, by reason of force majeure to perform its obligations and meet its responsibilities under this Contract, Client shall have the right to suspend or terminate this Contract on the same terms and conditions as are provided for in Article 49.1, "Termination by Client", except that the period of notice shall be seven (7) days instead of fourteen (14) days.

45.3 Force majeure as used in this Article means acts of God, war (whether declared or not), invasion, revolution, insurrection, or other acts of a similar nature or force.

**46. SUSPENSION BY Client**

46.1 Without prejudice to any other rights and remedies available to it, Client may by written notice to the Contractor suspend for a specified period, in whole or in part, payments to the Contractor or the Contractor's obligation to continue performance under this Contract, if in Client's judgment:

46.2 Any conditions arise which interfere, or threaten to interfere, with the successful completion of the services under this Contract, the execution of the Works or the accomplishment of the purpose thereof; or

46.3 The Contractor shall have failed, in whole or in part, to perform any of the terms and conditions of this Contract.

46.4 After suspension under Article 47.1 above, the Contractor shall be entitled to reimbursement by Client of actual and substantiated costs resulting from commitments entered into in accordance with this Contract prior to the commencement period of such suspension. The Contractor undertakes to use best efforts to minimize any such costs and shall include a provision in its contracts with sub-contractors, which entitles it to suspend such sub-contracts during any suspension period under this Contract.

#### **47. TERM AND TERMINATION**

47.1 This Contract shall commence on the Commencement Date and terminate upon payment of the final installment of the Contract Price; provided however that either Party may exercise its right to early termination in accordance with this Contract.

#### **48. TERMINATION BY Client**

48.1 Client may terminate this Contract at any time on thirty (30) days' written notice to the Contractor if, in Client's judgment, it is in Client's interest to do so.

48.2 If the Contractor fails, in whole or in part, to fulfill any of its obligations under this Contract in a timely manner Client may, by notice to the Contractor, demand that the Contractor perform those obligations. If (a) the Contractor fails to perform those obligations within thirty (30) days after receipt of such notice, or (b) the Contractor shall have become insolvent or taken steps to make accommodation with its creditors by reason of an inability to pay its debts as and when they come due, or (c) if control of the Contractor changes for any reason including by reason of insolvency (each an "Event of Default"), then Client may, without prejudice to any other rights or remedies and notwithstanding any suspension under the provisions of Article 47 above, terminate this Contract upon not less than fourteen (14) days written notice to the Contractor.

48.3 Upon termination of this Contract:

- a. the Contractor shall take immediate steps to terminate its services in a prompt and orderly manner and to reduce losses and to keep further expenditures to a minimum.
- b. the Contractor shall be entitled, except in the case of an Event of Default by the Contractor, to be paid for the work satisfactorily completed on the Works and for the materials delivered to the Site as of the date of termination, plus actual, substantiated costs resulting from commitments entered into prior to the date of termination as well as any reasonable substantiated direct costs incurred by the Contractor as a result of the termination, but the Contractor shall not be entitled to receive any other or further payment, or any damages for termination hereunder. In the case of this Contract between the Parties as to the existence of an Event of Default, the matter shall be resolved in accordance with the provision of Article 51 hereof.

#### **49. TERMINATION BY THE CONTRACTOR**

49.1 If Client fails, in whole or in part, to fulfill any of its obligations under this Contract in a timely manner the Contractor may, by notice to Client, demand that Client perform those obligations. If Client fails to perform those obligations within thirty (30) days after receipt of such notice, the Contractor may terminate this Contract upon not less than fourteen (14) days' written notice to Client. In the case of this Contract between the Parties as to whether Client has fulfilled such obligations, the matter shall be resolved in accordance with the provision of Article 52 hereof.

49.2 Upon termination of this Contract under this Article, the provisions of Article 49.3 a & b hereof shall apply.

## **50. ASSIGNMENT**

50.1 The Contractor shall not assign the whole or any part of this Contract or any benefit or interest in or under this Contract without the prior written agreement of Client. Failure to obtain such prior written agreement shall be considered an Event of Default under this Contract and Client shall have the right to terminate this Contract in accordance with Article 48 herein.

## **51. SETTLEMENT OF DISPUTES**

51.1 Amicable Settlement:

The Parties shall use their best efforts to settle amicably any dispute, controversy, or claim relating to this Contract. Where the Parties wish to seek such an amicable settlement through conciliation, the conciliation shall take place in according to such other procedure as may be agreed between the Parties.

51.2 Arbitration:

Any such dispute, controversy or claim which is not settled amicably within sixty (60) days after receipt by one Party of the other Party's request for such amicable settlement, shall be referred by either Party to arbitration in accordance with the Arbitration rules then in force. The Parties shall be bound by an arbitration award rendered as a result of such arbitration as the final adjudication of such dispute. The costs of the procedure shall be shared equally by the Parties. In no event shall Client be liable for incidental, indirect or consequential damages or for lost revenue or excess revenue. The arbitral tribunal shall have no authority to award interest in excess of four percent (4%) and such interest shall be simple interest only.

## **52. TAXES AND DUTIES**

- a. Client will issue an income tax withholding certificate to the contractor/vendor listing the gross payment, the amount of income tax withheld and the net contract payment along with a copy of the payment form and deposit receipt for transfer made to the designated Ministry of Finance (MoF) of Afghanistan bank account.
- b. According to article No. 73 of Income Tax law of 1384 (solar year) amendment to Article No. 72 the Client will withhold:
  - Two per cent (2%) of contract value, if the Contractor holds an update valid business license from the relevant institutions/authorities.
  - Seven per cent (7%) of contract value, if the Contractor does not have valid business license or an expired one.

## **53. OFFICIALS NOT TO BENEFIT**

53.1 The Contractor warrants that no official of Client has received or shall receive or shall be offered by the Contractor any direct or indirect benefit, including gifts or hospitality, arising from this Contract or the award of this contract. The Contractor agrees that breach of this provision is a breach of a  
n essential term of this Contract.

#### **54. CORRUPT AND FRAUDULENT PRACTICES**

- 54.1 Client strictly enforces a policy of zero tolerance concerning unethical, unprofessional or fraudulent acts of Client contractors. Client requires that all contractors associated with this Contract observe the highest standard of ethics during the execution of this Contract.
- 54.2 In pursuance of this policy Client defines for the purpose of this provision the terms set forth as follows:
- 54.3 Corrupt practice means offering, giving, receiving or soliciting anything of value to influence the action of a client or any other public official in the execution of this Contract; and
- 54.4 Fraudulent practice means a misrepresentation of facts in order to influence the execution of a contract to the detriment of the client, prior to or after submission, designed to establish Bids prices at artificial non-competitive levels and to deprive the client of benefits of free and open competition.
- 54.5 Client shall reject a Bid for award if it determines that the selected contractor has engaged in any corrupt or fraudulent practices in competing for the contract in question.
- 54.6 Client shall declare a contractor ineligible, either indefinitely or for a stated period of time, to be awarded a Client-financed contract if at any time Client determines that the contractor has engaged in any corrupt or fraudulent practices in competing for, or in executing the contract.

#### **55. CHILD LABOUR**

- 55.1 Client fully subscribes to the Convention on the Rights of the Child and draws the attention of potential suppliers and contractors to Article 42 of the Convention which inter alia requires that a child shall be protected from performing any work that is likely to be hazardous or to interfere with the child's education, or to be harmful to the child's health or physical, spiritual, moral or social development. The Contractor represents and warrants that it does not make use of child labor and that child labor shall not be used in the performance of its obligations under this Contract.

#### **56. AMENDMENT TO THE CONTRACT**

- 56.1 No change, amendment or modification to the Works, Contract Price or time to completion shall be accepted, or paid for, unless it has been agreed in writing between the Parties and has been incorporated in this Contract through an amendment to this Contract duly signed by a representative of each Party duly authorized.

#### **57. VARIATIONS**

- 57.1 Further to the requirement of Article 61 of this Contract, if the total scope of work is changed either by:
- 1) Client ordering or requesting an increase or decrease in the scope of work, or
  - 2) special conditions on site necessitating a change to the scope of work,



- 57.2 The Contractor shall send a request for variation as soon as he becomes aware of, or should have become aware of, the need for a variation. Within 14 (fourteen) days the Contractor shall provide all necessary details of the variation to enable Client to make an assessment of the entitlement.
- 57.3 Such variation shall be valued by Client in accordance with the rates shown in the Bill of Quantities in so far as they are applicable, and the monies due to the Contractor shall be increased or decreased accordingly.
- 57.4 If the rates in the Contract are not considered to be appropriate or applicable, Client shall for the purpose of valuation of variations fix such other rates as are considered reasonable.
- 57.5 No work shall proceed on any variation without a written instruction to that effect by Client.

**58. NOTICES**

- 58.1 Notices shall be deemed to be effective as follows: in the case of personal delivery, on delivery; in the case of registered mail, seven (7) days; in the case of facsimiles, twenty-four (24) hours following confirmed transmission.
- 58.2 Any notice, request or consent required or permitted to be given or made pursuant to this Contract shall be in writing, and addressed and sent by registered mail or facsimile to such Party as follows.

0

- a) If to (NGO Name):

**[Insert the name of NGO's representative]  
Client  
[ Address of NGO]**

- b) If to the Contractor:

Tel: \_\_\_\_\_

Fax: \_\_\_\_\_

Attn: \_\_\_\_\_

**59. EFFECTIVE DATE**

The effective date of this Contract shall be the date both Parties have signed the same.

**IN WITNESS WHEREOF**, the Parties hereto have caused this Contract to be signed in their respective names on the date written below.

[\[Subcontractor name\]](#),  
**CONTRACTOR**

FOR AND ON BEHALF OF [Client](#),

---

Signature

---

Signature

---

Name of Official

---

Name of Official

---

Date

---

Date

**SECTION II: FORM OF BID SECURITY, PERFORMANCE BOND  
& ADVANCE PAYMENT BANK GUARANTEE**

---

**FORM OF BID SECURITY (BANK GUARANTEE)**

(Note: The bidder may complete either this form of Bond or a form of Bank Guarantee or provide other acceptable security)

BOND No. \_\_\_\_\_

DATE BOND EXECUTED \_\_\_\_\_ By this bond we (Name of Bidder ) \_\_\_\_\_ ( thereafter called “ the principal” as principal and

(Name of Bank) \_\_\_\_\_ of the country of (Name of country of Bank) \_\_\_\_\_ authorized to transact business in the country of (Name if the country of employer) (hereinafter called “the Bank”) are held and finally bound unto (hereinafter called “ the Employer”) as obligee, in the sum of birr of the payment of which sum, well and truly to be made, we the said principal and Bank bind ourselves, our successors and assigns, jointly and severally firmly by these presents.

SEALED with our seals and dated this day of \_\_\_\_\_

WHEREAS, the principal has submitted a written Bid to the employer dated the \_\_\_\_\_ day of \_\_\_\_\_ 20\_\_ for the construction of \_\_\_\_\_

\_\_\_\_\_ (hereinafter called the “Bid”)

Now, therefore, the conditions of this obligation are:

- 1) If the principal withdraws his Bid during the period of Bid validity specified in the form of Bid or
- 2) If the principal, having been notified of the acceptance of his Bid Bond the Employer during the period of bid validity:
  - a) fails or refuses to execute the form of agreement in accordance with the instructions to Bidders if required: or
  - b) liable for a greater sum than difference between the amount of these said principal’s bid and the amount of the bid that is accept by the Employer

The Bank executing this instrument hereby agrees that its obligation will remain in force up to the including the date 90 days after the closing date for submission of bids as stated in the Invitation of bid or extended by the employer at any time prior to this date, notice of which extensions(s) to the Bank being hereby waived.

PRINCIPAL \_\_\_\_\_

BANK \_\_\_\_\_

SIGNATURES(S) \_\_\_\_\_

SIGNATURES(S) \_\_\_\_\_

Name & TITILE (S) \_\_\_\_\_

NAME(S) \_\_\_\_\_

\_\_\_\_\_

\_\_\_\_\_

SEAL \_\_\_\_\_

SEAL \_\_\_\_\_

**NOTE:**

The bidder should insert the amount of bond in words and figures, denominated in the currency of the employer's country of (Ethiopian Birr)

---

**FORM OF PERFORMANCE BOND**

By this bond (Name are Address of Contractor) \_\_\_\_\_  
as principal (hereinafter called the contractor) and Name, Legal tile and Address of Bank)

\_\_\_\_\_

As Bank (hereinafter called the Bank) are held and firmly unto (name and Address of Employer) \_\_\_\_\_  
oblige (hereinafter called employer in the amount of (Amount Bond) \_\_\_\_\_ (in words)

\_\_\_\_\_

For the payment of which sum will and truly to be made in the types and proportions of currencies in which the contract price is payable the contractor and the Bank bind themselves, their heirs, executors administrators successors and assigns, jointly and severally, firmly these presents.

Whereas the contractor has entered into a written agreement with Employer dated the \_\_\_\_ day of \_\_\_\_\_ 20\_\_ for (Name Contract) \_\_\_\_\_  
\_\_\_\_\_ the construction of \_\_\_\_\_

\_\_\_\_\_

accordance with the documents plans, specifications and amendment thereto, which to the extent herein provided for, are by reference made part hereof and are hereinafter referred to as the contract.

Now therefore, the condition of this obligation is such that if contractor shall properly and faithfully perform the said contract (including any amendments thereto) then this obligation shall be null and void otherwise it shall remain in full force and effect. Whenever the contractor shall be, and declared by the employer to be in default under the contract the Employer having performed the Employer's obligations thereunder, the Bank may properly remedy the default or shall promptly

- 1) Complete the contract in accordance with its terms and conditions or
- 2) Obtain a bid or did from qualified Bidders for submission to the employer for completing the contract in accordance with its terms and conditions, and upon determination by the employer and the Bank of the lowest responsive Bidder arrange for a contract between such Bidder and Employer and make available as work progresses (even though there should be a default or a succession of defaults under the contract or contracts of

---

completion arranged under this paragraph) sufficient fund to pay the cost of completion less the balance of the contract price but not exceeding including other costs and damages for which the Bank may be liable hereunder, the amount set forth in the first paragraph hereof. The tem “ balance of the contract price” as use in this paragraph shall mean the total amount payable by Employer to contractor under the contract, less the amount property paid by Employer to contractor or

- 3) Pay the Employer the amount required by Employer to complete the contract in accordance with its terms and conditions up to a total not exceeding the amount of this bond.

The Bank shall not be liable for a greater sum than the specified penalty of the this bond. Any suit under this bond must be instituted before the expiration of year from the date of the issuing of the maintenance certificate. No right of action shall accrue on this bond to or for the use of any person or corporation other than the Employer named herein or the heir executors administrators successors and assigns of the Employer. In testimony whereof the contractor has hereunto set his hand and affixed his seal and the Bank has caused these presents to be sealed with his corporate seal duly attested by the signature of the legal representative this \_\_\_\_\_ day of \_\_\_\_\_ 20\_\_.

SIGNED, SEALED AND DELIVERED

By the Bank \_\_\_\_\_ by the contractor \_\_\_\_\_

In the presence of \_\_\_\_\_ In the presence of \_\_\_\_\_  
(witness) (witness)

---

**BANK GUARANTEE FOR ADVANCE PAYMENT Not Applicable**

To: \_\_\_\_\_(name of employer)  
\_\_\_\_\_(address of Employer)

\_\_\_\_\_(name of contact)

**Gentlemen:**

In accordance with the provisions of the conditions of contract, sub-clause 34 (“Advance payment”) of the above-mentioned contract. \_\_\_\_\_ (name and address of contractor) ( hereinafter called” the contractor”) shall deposit with \_\_\_\_\_ (*name of Employer*) a bank/insurance guarantee to his /her proper and faithful performance under the said clause of the contact in an amount of \_\_\_\_\_(amount of Guarantee)  
\_\_\_\_\_(amount in words)

We, the \_\_\_\_\_(bank), as instructed by the Contractor, agree unconditionally and irrevocably to guarantee as primary obligator and not as Bank merely, the payment to \_\_\_\_\_(name of employer) on his first demand without whatsoever right of objection on out part and without his firs claim to the contractor, in the amount not exceeding.  
\_\_\_\_\_(amount of guarantee)  
\_\_\_\_\_(amount in word) such amount to be reduced periodically by the amounts recovered by you from the proceeds of the contract.

We further agree that no change or addition to or other modification of the terms of the contract or of works to be performed there under or of any of the contract documents which may be made between \_\_\_\_\_(name of employer) and the contractor, shall in any way release us from any liability under this guarantee, and we hereby waive notice of any such change, addition, or modification.

No drawing may be made by you under this guarantee until we have received notice in writing from you that an advance payment of the amount listed above has been paid to the contractor pursuant to the contract.



---

This guarantee shall remain valid and in full effect from the date of the advance payment under the contract until \_\_\_\_\_ (name of Employer) receives full repayment of the same amount from the contractor.

Yours truly,

SIGNATURE AND SEAL \_\_\_\_\_

Name of bank; \_\_\_\_\_

Address: \_\_\_\_\_

Date: \_\_\_\_\_

**SECTION III: PRICED BOQ**

**SECTION IV: DRAWINGS**