

Main Office

Golayee Wazirabad
PO Box 208
Kabul, Afghanistan
Phone: +93 202230752
Mobile: +93 700288232
E-mail: dacaar@dacaar.org
Website: www.dacaar.org

REQUEST FOR QUOTATION

**Supply and Installation of Complete Solar Water Supply System for
Sayed Abad and Kotal Sorkh Villages Injil District of Herat Province**

اعلان برای داوطلبی برای تهیه و نصب واتر پمپ با سیستم انرژی آفتابی
در قریه های سید آباد و کوتل سرخ ولسوالی انجیل ولایت هرات

دفتر مرکزی
گولایی وزیرآباد
پست بکس ۲۰۸
کابل، افغانستان
تلفون: +۹۳۲۰۲۲۳۰۷۵۲
موبایل: +۹۳۷۰۰۲۸۸۲۳۲
ایمیل: dacaar@dacaar.org
وبسایت: www.dacaar.org

DACAAR RFQ 29 PRF-239 and 240/ECHO/2306-ECHO/ECHO1.6.9/WSHE/HRT-2002/03.2024

Date: March 28, 2024

DACAAR invites interested parties to submit their sealed offers for Supply & Installation of Two Complete Sets Solar Water Supply Systems with Fixed Stands and Water Pumps for Injil District of Herat Province as described in Annex (I).

داکار از کمپنی های علاقمند و واجد شرایط که خواهش اشتراک در پروسه داوطلبی داکار را داشته باشند دعوت به عمل میآورد تا در داوطلبی برای تهیه و نصب دو سیت مکمل سولر غیر متحرک واتر پمپ زیر آبی مجهز با سیستم انرژی آفتابی در ولسوالی انجیل ولایت هرات اشتراک نمایند که تفصیلات آن در ضمیمه (I) تذکر یافته است.

Sealed offers must reach to DACAAR Main Office Logistics Unit located in Street No. 12, Paykobe-Naswar, Qalae-Fathullah, Kabul Province till 4:00 pm April 03, 2024.

آفرها باید الی تاریخ 03 اپریل 2024 ساعت 4:00 عصر به شعبه لوجستیک دفتر مرکزی داکار واقع پایکوب نساوار سرک 12 قلعه فتح الله ولایت کابل سپرده شود.

The bid opening session will be held on April 04, 2024 at 10:00am in DACAAR Main Office in Kabul Province and the bid winner will be notified shortly after the bid opening session.

مجلس آفرگشایی ساعت 10:00 قبل از ظهر تاریخ 04 اپریل 2024 در دفتر مرکزی داکار در ولایت کابل صورت میگیرد که متعاقباً برنده داوطلبی در اسرع وقت اطلاع خواهد یافت.

Terms and Conditions for the bid winner/participation

شرایط برای برنده داوطلبی/ اشتراک کننده گان

1. Delivery and Installation of Solar Water Supply System is in Sayed Abad and Kotal Sorkh Villages Injil District of Herat Province as described in Annex (II).
2. Installation & Delivery of Solar pump & solar system should be carried out by the company technicians.
3. DACAAR technical staff at site will inspect the function of solar system water pumps, before delivery and after installation in the targeted area.
4. The bidders have to provide solely information regarding the panels, panels stand and pumps, Also, prepare all the lists of materials needed in this project and attach the design of the solar system to their offer. (e.g. name of manufacturer etc.). Pump daily output design is also needed; otherwise, the offer will not be accepted. However, the materials for this project is herein inlisted in Annex (I), the supplier still can provide their own list required as per their deliberation, as well as to provide desing for connecting the solar panels with main switch and inverter.

1. انتقال و نصب سولر غیر متحرک واتر پمپ زیر آبی مجهز با سیستم انرژی آفتابی در قریه های سید آباد و کوتل سرخ ولسوالی انجیل ولایت هرات که در ضمیمه (II) ذکر گردیده صورت میگیرد.
2. انتقال و نصب سولر پمپ و سولر سیستم باید توسط اشخاص مسلکی شرکت صورت بگیرد.
3. پرسونل داکار نحوه کار سولر سیستم و واتر پمپ را قبل از انتقال و بعد از نصب کردن در ساحه مربوطه نظارت خواهند نمود.
4. داوطلبان مکلف اند تا معلومات (مشخصات) مکمل را در مورد پنل های سولر، انورتر دیجیتال یا کنترولر عمومی دیجیتلی و پمپ زیر آبی که توسط انرژی سولر کار میکند، آب دهی روزانه یا ساعتوار، و کمپنی ساخت پنل ها و پمپ ها را ارائه نمایند همچنان تمام لست مواد مورد ضرورت برای این پروژه لست شده است، ولی باز هم داوطلبان میتوانند که لست مواد مورد ضرورت این پروژه که اضافه ویا کمبود از لست داده شده باشد ضمیمه آفر خویش نمایند، همچنان لین دوانی شیشه های سولر همراهی مین سویچ و انورتر را ترسیم و ضمیمه آفر خود نمایند در غیر آن آفر که معلومات فوق الذکر در آن گنجانیده نشده باشد، داکار از آن صرف نظر خواهد کرد.

5. The contractor must practically show total power (kw) generated by solar panels in proportion to the number of solar panels and submit DACAAR field colleague verified documents to DACAAR main office.
 6. Minimum three years' guarrenty of complete system is required after successfully installation of complete solar systems and this fact must be clearly mentioned in the offer.
 7. 3% of total contract value will be seized as a service/ maintenance guarantee with DACAAR for three years. This amount will be refunded when the service/ maintenance guarantee period is successfully served.
If, the contractor is not responding during one week for the issue of system maintenance, then DACAAR reserves the rights to use the 3% guarantee to fix the system.
 8. In case of delay without logical reasons in delivery & installation of Solar Systems 0.5% of total cost of undelivered items/ incomplete work will be charged as penalty for each official day of delay.
 9. Prices shall be given in Afghani (AFN) and shall include transport plus loading, unloading and complete installation of the systems in targeted areas. Offers without sign and stamp will not accepted.
 10. The bid winner must deposit 10% of total contract value as a contract performance guarantee to DACAAR Bank Account, the amount is refundable after successful completion of the contract.
 11. 2% Tax will be applicable on the companies which have valid business license and 7% Tax will be applicable on the companies that have invalid business license or on individuals who don't have business license, will be deducted from the contractor as a withholding tax. DACAAR will pay that amount to Ministry of Finance, the amount starts from (1 AFN).
 12. Payment will be made after successfully & complete installation of solar pump with submission of invoice, confirmation of DACAAR relevant sites accountable within 15 working days.
5. قراردادگیرنده باید پاور مجموعی سیستم را نظر به تعداد شیشه های سولر عملاً نشان داده و اسناد آنرا که تصدیق انجنیر ساحوی داکار در آن موجود باشد، به دفتر داکار ارائه نماید.
 6. حد اقل معیاد تضمین و خدمات مکمل سیستم بعد از نصب تسلیمدهی مکمل سولرسیستم برای مدت سه سال میباشد، که این موضوع باید بشکل واضح و روشن در اسناد داوطلبی مشخص گردد.
 7. 3% از مجموع ارزش قرارداد بطور ضمانت به مدت سه سال نزد داکار محفوظ میماند، و بعد از تکمیل مؤفقاته دوره ضمانت کار کرده گی سیستم این مبلغ به قرارداد گیرنده قابل پرداخت میباشد.
اگر قرارداد گیرنده در طول یک هفته به موضوع ترمیم و نگهداری شبکه پاسخ ندهد، داکار حق استفاده از ضمانت 3 فیصد قید شده را برای ترمیم سیستم محفوظ میدارد.
 8. در صورت تأخیر رساندن سیستم ها بدون عذر موجه در وقت معینه آن، مبلغ 0.5 فیصد از ارزش اموال/کار تأخیر شده به طور جرمانه در برابر هر روز رسمی تأخیر از طرف قراردادی تأدیه خواهد گردید.
 9. قیمت ها باید به افغانی داده شود و شامل قیمت (مالیه دولتی، انتقال، بارگیری، تخلیه و نصب سولرسیستم باشد) قیمت های بدون مهر و امضا قابل قبول نمیشد.
 10. شرکت برنده باید مبلغ 10% از مجموع ارزش قرارداد را بحیث تضمین اجرائیوی مؤفقاته قرارداد را به حساب داکار جمع نماید، و مبلغ مذکره بعد از تکمیل مؤفقاته قرارداد باز پرداخت میباشد.
 11. 2% مالیه برای شرکت هائیکه دارای جواز با اعتبار میباشد، و 7% مالیه برای شرکت هائیکه دارای جواز معیاد اعتبار آن ختم باشد، و یا اشخاصیکه جواز ندارند توسط داکار وضع گردیده و به وزارت مالیه پرداخت میشود، آغاز مبلغ مالیه از (1 افغانی) میباشد.
 12. تأدیه پول بعد از تکمیل نمودن مؤفقاته قرارداد و بعد از تصدیق نمودن مسؤل ساحوی داکار در جریان 15 روز کاری قابل اجرا میباشد.

13. Award of the contract will be based on the price, quality, capacity & potentiality of bidder. The evaluation of bidder and their product will be carried out and DACAAR reserves the right to make the decision of awarding contract.
13. برنده شدن قرارداد نظر به قیمت، کیفیت، توانائی و ظرفیت داوطلب بوده، و بعد از بررسی کمپنی و اجناس صورت میگیرد. البته داکار حق تصمیم گیری در این زمینه را دارا میباشد.
14. DACAAR (Logistics Unit) adheres to National and International laws on child labour, DACAAR makes sure all its suppliers and vendors abide by such laws preventing child labour in all DACAAR activities countrywide.
14. دفتر داکار (شعبه لوژیستیک) با در نظر داشت قوانین ملی و بین المللی برای جلوگیری از کار کودکان مصمم بوده و سعی میکند که تمام فعالیتهای تهیه کننده گان و مشتریان این اداره به این اصل پایبند باشند.
15. DACAAR has a zero-tolerance policy on sexual exploitation, abuse and harassment, which is defined and described in the policy document "DACAAR policy on preventing and handling sexual exploitation, abuse and harassment".
15. داکار دارای پالیسی عدم تحمل در مورد سوء استفاده، بد رفتاری و آزار و اذیت جنسی میباشد و موقف داکار در همچون مسایل بطور تفصیلی در پالیسی مذکور تشریح شده است.
16. The Humanitarian Organizations (HO) may conduct on- site visit in the contractor's premises (or may take similar measures) to ensure compliance.
16. سازمان های بشر دوستانه (HO) ممکن است تا از محلات و سایت ها به بخاطر اطمینان خاطر و تطبیق درست کار توسط قرار داد گیرنده بازدید بعمل آورده و یا ممکن است اقدامات مشابهی را انجام دهند.

For more details, please visit DACAAR Logistics Unit Main Office Kabul, Sunday through Thursday, from 8:00AM to 03:00PM. Or contact on below Email Addresses:

jamal@dacaar.org or wasimullah@dacaar.org

Yours Sincerely,

Manager – Logistics Unit

Date: March 28, 2024



ANNEX (I)

Budget Breakdown / فورم ارانه آفر

DACAAR RFQ 29 PRF-239 and 240/ECHO/2306-ECHO/ECHO1.6.9/WSHE/HRT-2002/03.2024

Lot I: Complete Solar Water Supply System in Sayed Abad Village Injil District of Herat Province:

S/N	Product Specifications	Unit	Total QTY	Unit Price (AFN)	Total Price (AFN)
1	Submersible Water Pumps, European Made IP(65-68). Total static head 91m with water flow 1.05 liter/sec.	No	1		
2	Digital Solar Inverter, European Made IP(65-68) with water proof metal box and proper lock. The digital Solar Inverter to provide required power from solar panels to the submersible water pump and run the system normally in the year (Jan-Dec).	No	1		
3	Monocrystalline/Polycrystalline Solar Panels European made Grade A IP68. The solar panels will be according to the required submersible pump and inverter powers.	Watts	5,400		
4	Stand for the Solar Panels to be considered according to attached specifications and drawings.	lump sum	1		
5	Submersible Drop power Cable according to pump power design from Inverter to Submersible water pump (made in Turkey or Iranian).	Meter	128		
6	Power Cable 1*6mm ² from Solar panels to Inverter (Made in Turkey or Iranian).	Meter	80		
7	Dry Running sensor inside the well , for protection of submersible water pump with required cable and other needed accessories.	lump sum	1		
8	Grounding/earthing (earthing System or Grounding System of network work as a safety measure from lightening arrestor to protect human life as well as equipment and other needed accessories according to attached specifications and drawings).	Set	1		
9	Electrical conduit pipe for external power cables (Made in Taiwan).	Meter	45		
10	Auto fuses AC/DC (Made in Turkey) with other required accessories.	lump sum	1		
11	Wire tie white and black	Pocket	2		
12	Water flow meter and needed fittings/ accessories in accordance the pump rising pipe diameter (Made in Turkish or Iranian).	lump sum	1		
13	Plastic rope for holding solar submersible water pump diameters (16)mm φ with all needed accessories	Meter	220		
14	Delivery pipe (PE 100, PN16 DN50mm) according to design with required connections, and necessary fittings from submersible water pump outlet up to Ground water Reservoir inlet.The trenches excavation must be (1m deep and 0.7 m wide).	Meter	678		
15	Transportation to village	lump sum	1		
16	Installation charges	lump sum	1		
Grand Total including 2/7% Government Tax, Transportation and Installation Costs: AFN					
Note: The submersible water pump, inverter, solar panel and other important accessories must be European Made. China product is not acceptable.					

Bidder Name: _____ اسم آفر دهنده:

Address & Stamp: _____ آدرس کمپنی و مهر کمپنی:

Mobile No: _____ نمبر موبائیل:

Email Address: _____ آدرس ایمل:

Delivery Time: _____ زمان تحویلدهی:

ANNEX (I)

Budget Breakdown / فورم ارانه آفر

DACAAR RFQ 29 PRF-239 and 240/ECHO/2306-ECHO/ECHO1.6.9/WSHE/HRT-2002/03.2024

Lot II: Complete Solar Water Supply System in Kotal Sorkh Village Injil District of Herat province:

S/N	Product Specifications	Unit	Total QTY	Unit Price (AFN)	Total Price (AFN)
1	Submersible Water Pumps, European Made IP(65-68). Total static head 107m with water flow 1liter/sec.	No	1		
2	Digital Solar Inverter, European Made IP(65-68) with water proof metal box and proper lock. The digital Solar Inverter to provide required power from solar panels to the submersible water pump and run the system normally in the year (Jan-Dec).	No	1		
3	Monocrystalline/Polycrystalline Solar Panels European made Grade A IP68. The solar panels will be according to the required submersible pump and inverter powers.	Watts	5,400		
4	Stand for the Solar Panels to be considered according to attached specifications and drawings.	lump sum	1		
5	Submersible Drop power Cable according to pump power design from Inverter to Submersible water pump (made in Turkey or Iranian).	Meter	128		
6	Power Cable 1*6mm ² from Solar panels to Inverter (Made in Turkey or Iranian).	Meter	80		
7	Dry Running sensor inside the well , for protection of submersible water pump with required cable and other needed accessories.	lump sum	1		
8	Grounding/earthing (earthing System or Grounding System of network work as a safety measure from lightening arrestor to protect human life as well as equipment and other needed accessories according to attached specifications and drawings).	Set	1		
9	Electrical conduit pipe for external power cables (Made in Taiwan).	Meter	45		
10	Auto fuses AC/DC (Made in Turkey) with other required accessories.	lump sum	1		
11	Wire tie white and black	Pocket	2		
12	Water flow meter and needed fittings/ accessories in accordance the pump rising pipe diameter (Made in Turkish or Iranian).	lump sum	1		
13	Plastic rope for holding solar submersible water pump diameters (16)mm ϕ with all needed accessories	Meter	220		
14	Delivery pipe (PE 100, PN16 DN50mm) according to design with required connections, and necessary fittings from submersible water pump outlet up to Ground water Reservoir inlet.The trenches excavation must be (1m deep and 0.7 m wide).	Meter	453		
15	Transportation cost to village Installation charges	lump sum	1		
16	Installation charges	lump sum	1		
Grand Total including 2/7% Government Tax, Transportation and Installation Costs: AFN					
Note: The submersible water pump, inverter, solar panel and other important accessories must be European Made. China product is not acceptable.					

Bidder Name: _____ اسم آفر دهنده:

Address & Stamp: _____ آدرس کمپنی و مهر کمپنی:

Mobile No: _____ نمبر موبائیل:

Email Address: _____ آدرس ایمل:

Delivery Time: _____ زمان تحویلدهی:

ANNEX (II)

**Information about Types and Guaranty/Warranty of Solar Panels and Solar Pumps / معلومات و گرنٹی سولر پنل و پمپ /
DACAAR RFQ 29 PRF-239 and 240/ECHO/2306-ECHO/ECHO1.6.9/WSHE/HRT-2002/03.2024**

Complete Solar Water Supply System in Sayed Abad and Kotal Sorkh Villages Injil District of Herat Province:

No	Manufacturer of solar Submersible water pumps (Name of Company)	Guaranty period of submersible Water pumps (year)	Name (Model) of Solar Panels (Name of company)	Guaranty period of solar panels (year)	Name (Model) of Digital water proof Inverter (Name of company)	Guaranty period of water proof Inverter (year)
I	Name of company: Model or out let size by inch: Total power by Kw: Made in:		Name of company: Model & out put by Watt: Made in:		Name of company: Model: Total power by Kw: Made in:	
II	Name of company: Model or out let size by inch: Total power by Kw: Made in:		Name of company: Model & out put by Watt: Made in:		Name of company: Model: Total power by Kw: Made in:	

ANNEX (III)
Tentative Work Plan / پلان تخمینی کار
DACAAR RFQ 29 PRF-239 and 240/ECHO/2306-ECHO/ECHO1.6.9/WSHE/HRT-2002/03.2024

Complete Solar Water Supply System in Sayed Abad and Kotal Sorkh Villages Injil District of Herat Province:

Lot#	QTY	Items Description	Location of Installations	Contract Date	Completion Date
I	1 Set	Supply and Installation of Complete Solar Water Supply System Water Pump	Sayed Abad Village Injil District of Herat Province	Starts Upon DACAAR Contract Final Approval	May 10, 2024
II	1 Set	Supply and Installation of Complete Solar Water Supply System Water Pump	Kotal Sorkh Village Injil District of Herat Province	Starts Upon DACAAR Contract Final Approval	May 10, 2024

ANNEX (IV)
Technical Specification for Solar Pump Systems
DACAAR RFQ 29 PRF-239 and 240/ECHO/2306-ECHO/ECHO1.6.9/WSHE/HRT-2002/03.2024

Part I: Complete Solar Water Supply System in Sayed Abad Village Injil District of Herat Province:

S/No	Specification	Unit	Quantity	Remark
1	uPVC Casing pipes/filters Class E installed in the Tube Well	M	110.0	Inner diameter of uPVC Casing pipe is 8"= 203.2mm.
2	Total Depth of Production Well (PW)	M	110.0	Plan
3	Static Water level (SWL) of the Production Well	M	15.0	Plan
4	Well discharge	Lit/Sec	2.50	Plan
5	Water Draw Down of Tube Well	M	20.0	Plan
6	Dynamic Water Level in the Production Well	M	35.0	Plan
7	Submersible Water Pump Installation Depth	M	108.0	Plan
8	Height of Water Tank from the Well surface to top of the water tank	M	46.0	The water Tank ground surface is 43m higher than the Tube Well Surface + 3m height of the water tank.
9	Length of water delivery Pipe (PE 100-PN16 DN50mm) from submersible water pump to the Water Tank base.	M	678.0	The water tank is located 570m away from the Tube well, The trench excavation must be (1m deep and 0.7 m wide).
10	Length of Electrical Cable from Pump to Inverter	M	128.0	Solar Panel stand is (20)m away from Tube Well and inverter is 10m away from solar panels, the cable power losses will be calculated by bidder/supplier in accordance to the cable length and pump power.
11	equired Discharge	Lit/Sec	1.05	During handover the solar system should work for 8 hours/day and provide 30.24 m ³ /day
12	Static Head	M	91.0	1 bar extra for best water flow inside the Water Tank.
13	Total head	M	Static Head + Head losses	Head losses will be calculated by bidder/Supplier, according to delivery PE Pipe length, diameter and fittings for calculation of Total head.

ANNEX (IV)
Technical Specification for Solar Pump Systems
DACAAR RFQ 29 PRF-239 and 240/ECHO/2306-ECHO/ECHO1.6.9/WSHE/HRT-2002/03.2024

Part II: Complete Solar Water Supply System in Kotal Sorkh Village Injil District of Herat Province:

S/No	Specification	Unit	Quantity	Remark
1	uPVC Casing pipes/filtters Class E installed in the Tube Well	M	110.0	Inner diameter of uPVC Casing pipe is 8"= 203.2mm.
2	Total Depth of Production Well (PW)	M	110.0	Plan
3	Static Water level (SWL) of the Production Well	M	18.0	Plan
4	Well discharge	Lit/Sec	2.70	Plan
5	Water Draw Down of Tube Well	M	37.00	Plan
6	Dynamic Water Level in the Production Well	M	55.00	Plan
7	Submersible Water Pump Installation Depth	M	108.0	Plan
8	Height of Water Tank from the Well surface to top of the water tank	M	42.0	The water Tank ground surface is 39m higher than the Tube Well Surface + 3m height of the water tank.
9	Length of water delivery Pipe (PE 100-PN16 DN50mm) from submersible water pump to the Water Tank base.	M	453.0	The water tank is located 345m away from the Tube well, The trenche excavation must be (1m deep and 0.7 m wide).
10	Length of Electrical Cable from Pump to Inverter	M	128.0	Solar Panel stand is (20)m away from Tube Well and inverter is 10m a way from solar panels, the cable power losses will be calculated by bidder/supplier in accordance to the cable length and pump power.
11	Required Discharge	Lit/Sec	1.00	During handover the Solar System should work for 8 hours/day and provide 28.8 m3/day
12	Static Head	M	107.00	1 bar extra for best water flow inside the Water Tank.
13	Total head	M	Static Head + Head losses	Head losses will be calculated by bidder/Supplier, according to delivery PE Pipe length, diameter and fittings for calculation of Total head.

Some Necessary Specifications:

1. When constructing multiple fixed steel and RCC stands, it is important to use reinforced concrete with a mixture ratio of M (1:1.5:3). The solar fixed stand is meant to be located on the ground, and the embedded strong hooks (J bolt 16mm steel bar) must be placed in the RCC column/ring beams. All steel bars should be deformed 60 grade and used in accordance with the attached drawing of the solar panels fixed stand. If solar stand is on the ground, 5cm PCC M (1:2:4) is under RCC footings and 5cm gravel/crusher on the proper compacted base according to the attached drawings of solar panels fixed stand. If solar panels are on the roof, the RCC ring beam size will be (25*25) cm, 4N12 and stirrup diameter is 10mm on 20cm c/c.
2. Under the RCC footings, 5cm PCC M (1:2:4) with 5cm gravel/crusher on the properly compacted base is used for the solar panel fixed stand according to the attached drawings.
3. Potential bidders should consider the use of 50x50mm steel angle iron, with an average thickness of 4mm, for vertical, horizontal, and crossed stands to support solar panel frames. Additionally, the use of 100x45mm steel girders with an average thickness of 8mm, secured with proper nut and bolts or welding at all joints, is recommended to resist all types of loads and pressures such as high winds, heavy snow, and earthquakes. Please refer to the attached drawings of the solar panel fixed stands for more information.
4. The angle irons of solar panels fixed stand should be well protected, it's recommended to apply proper corrosion-resistant coatings as well as additional two oil coats.
5. The location of the solar system and solar fixed stand should be adjusted according to the selected site and well-pumping test result.
6. Bidders are required to calculate the total head and power losses in pipes, fittings, and power cables in accordance with the system requirements and their own design. It is important to note that extra charges will not be accepted, except in exceptional cases where the Deputy Director/Head of Program approves it, and only if the situation demands it. However, in case of any ground reality, deductions are possible. It is mandatory to ground/earth all the elements, including the solar system lightning arrester, by connecting them one by one to the ground copper rod using Copper-Cabled, Aluminum rod or box antenna as per the drawing of the fixed stand for the solar panel.
7. It is important to consider the wirings of the solar panels (series and parallel) based on the power requirements of the submersible pump and the inverter.

Note: It is crucial that the submersible water pump, controller/inverter, and solar panels are of European made and comply with all technical specifications and standard norms (national and international). For instance, the solar panel must be EU made, grade A and produced recently, with an IP68 rating. The production company confirmation and all certificates are required for the solar panel, pump and inverter. Additionally, the inverter should have an IP65-68 rating. As this is an emergency project with limited time therefore, we designed/requested solar system as planned, as the well is not constructed so the design of the solar system may change as per actual design parameters.

ANNEX (V)

Drawings & Design / دیزاین

DACAAR RFQ 29 PRF-239 and 240/ECHO/2306-ECHO/ECHO1.6.9/WSHE/HRT-2002/03.2024

Complete Solar Water Supply System in Sayed Abad and Kotal Sorkh Villages Injil District of Herat Province

Note:

- 1-RCC Concrete Footing and Column M(1:1.5:3).
 - 2-J-Anchor Bolt 16mm.
 - 3-Deformed Grade 60 steel bar Dia.10mm according to drawing.
 - 4-Steel angle iron (2"x2"x4mm).
 - 5-Steel girder mini. sizing (10cmx4.5cmx8mm).
- PCC M(1:2:4).
 Foundation Compacted 95%.
 Potable water used.

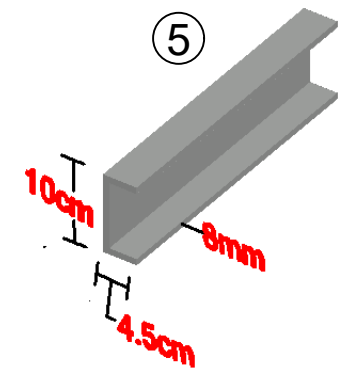
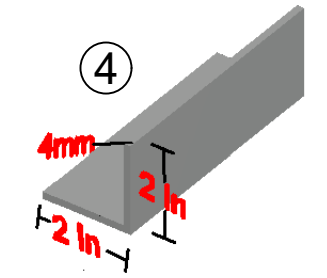
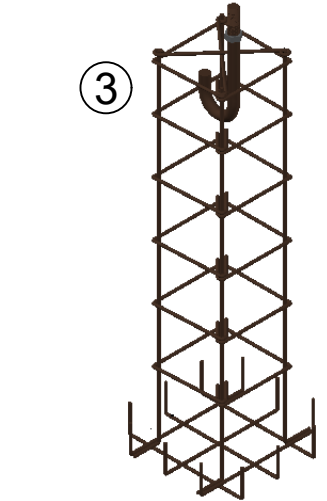
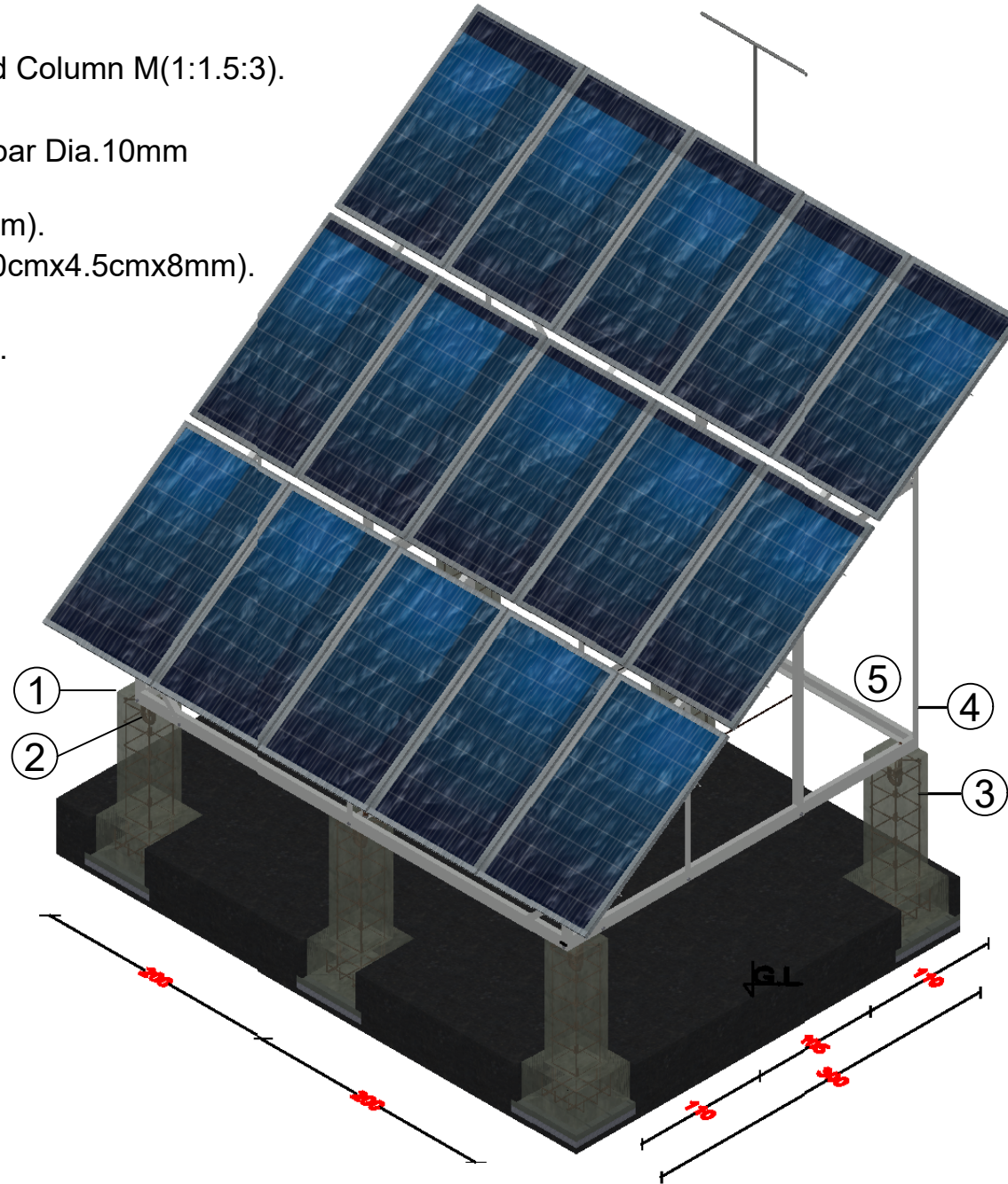
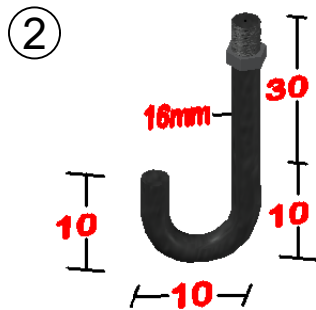
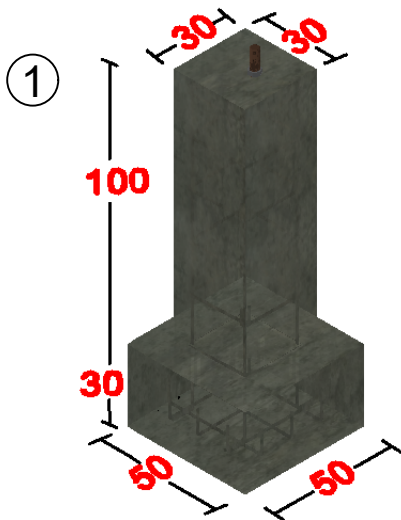

DACAAR / PROGRAMME	Funded By	Any	Village	Any	Drawn & Designed by	Survey/Design Team	Dim. Cm	Sheet Index 1/4	Project Title	Solar Design 3D
	Implemented By	DACAAR	District	Any	Reviewed By	Eng.Sayed Najib Jalal			Drawing Title	South East Isometric
			Province	Any	Checked & Approved By	Eng. Abdul Wali Muslih			Date :	2024

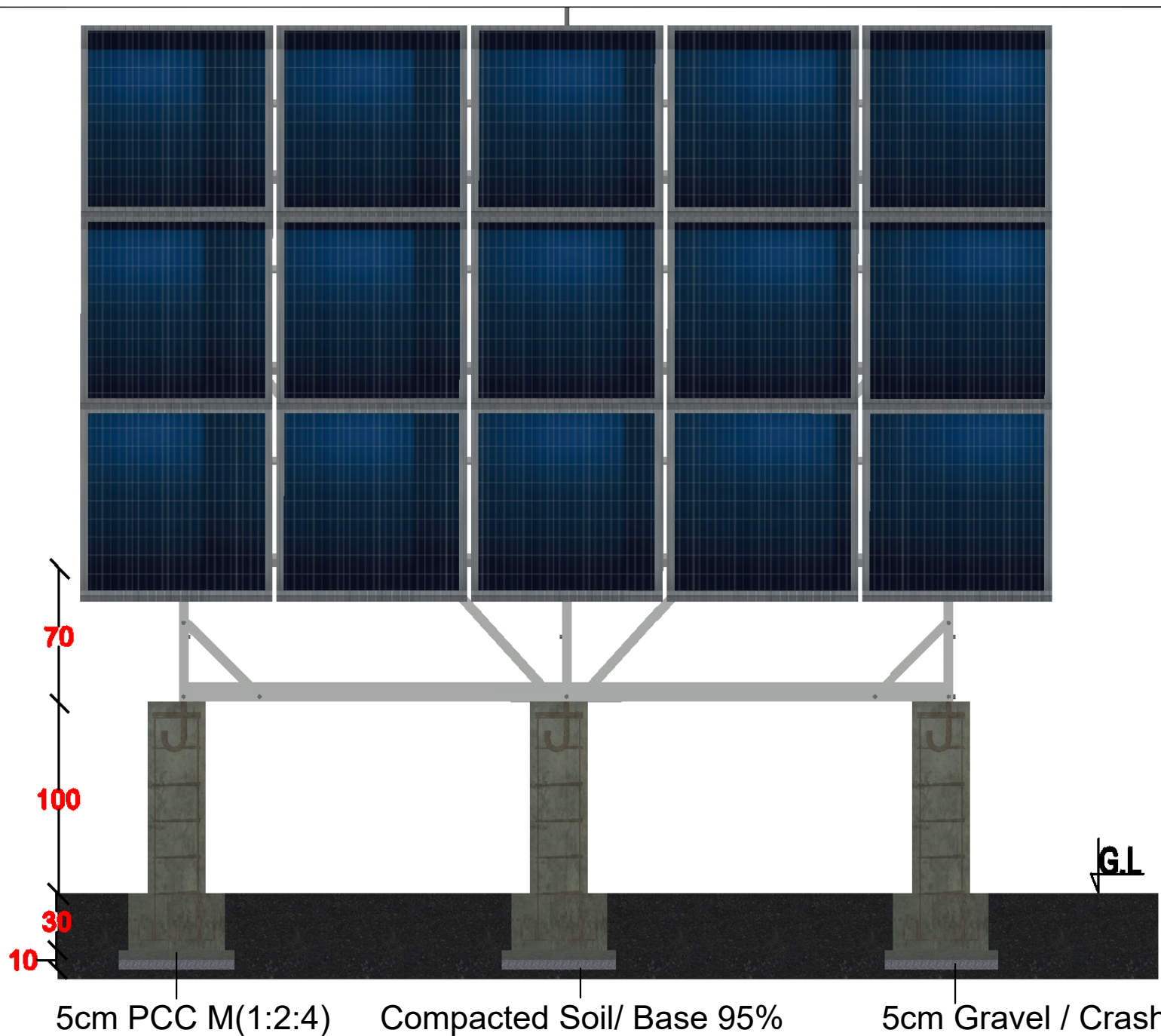

5cm PCC M(1:2:4)

Compacted Soil/ Base 95%

5cm Gravel / Crash

DACAAR / PROGRAMME	Funded By	Any	Village	Any	Drawn & Designed by	Survey/Design Team		Sheet Index	Project Title	Solar Design 3D
	Implemented By	DACAAR	District	Any	Reviewed By	Eng.Sayed Najib Jalal			Drawing Title	Front View
			Province	Any	Checked & Approved By	Eng. Abdul Wali Muslih			Date :	2024

Angle Θ = According to bidder solar system design

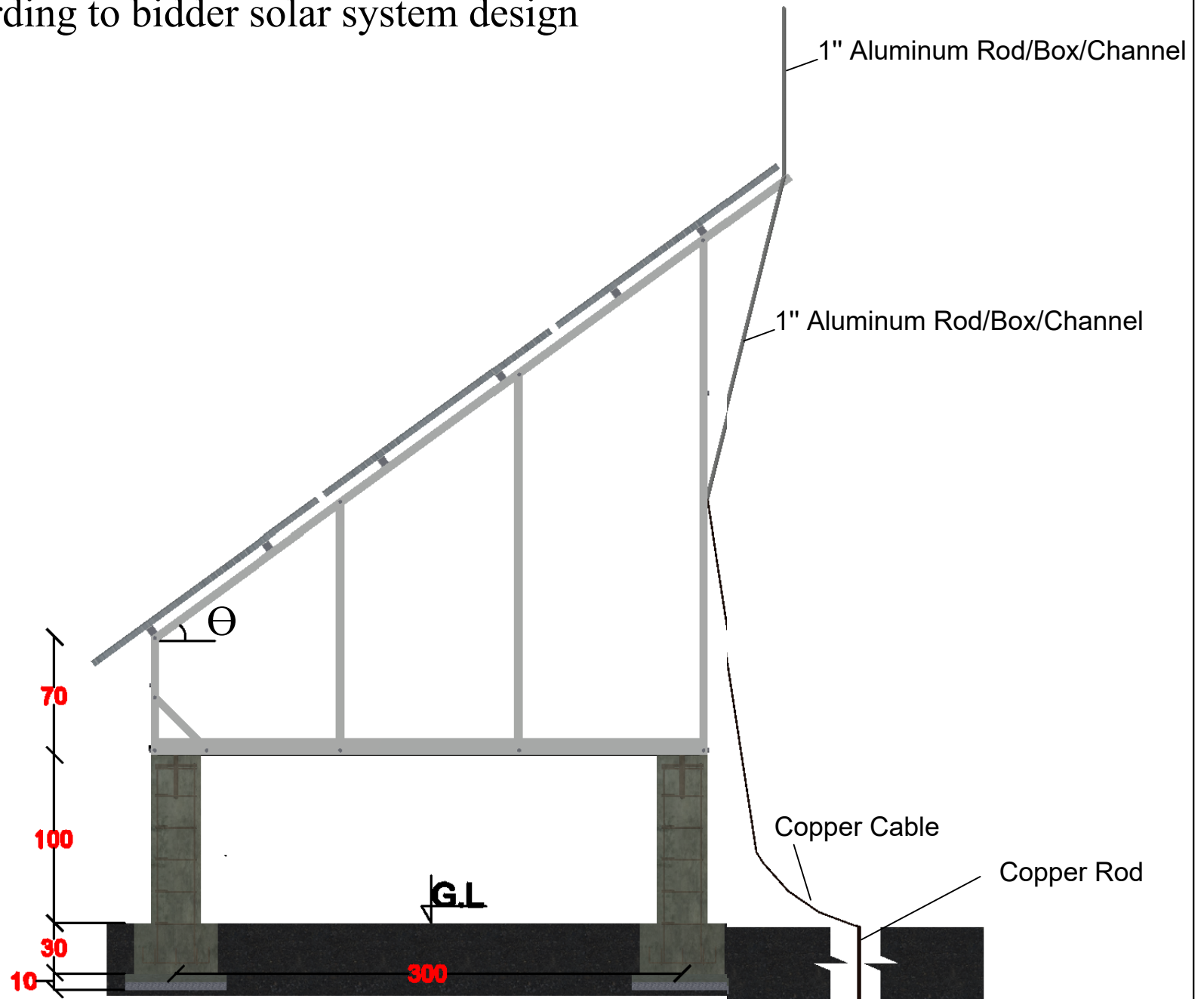

DACAAR / PROGRAMME	Funded By	Any	Village	Any	Drawn & Designed by	Survey/Design Team	Dim Cm	Sheet Index	Project Title	Solar Design 3D
	Implemented By	DACAAR	District	Any	Reviewed By	Eng.Sayed Najib Jalal		3 4	Drawing Title	Right Side View
			Province	Any	Checked & Approved By	Eng. Abdul Wali Muslih			Date :	2024

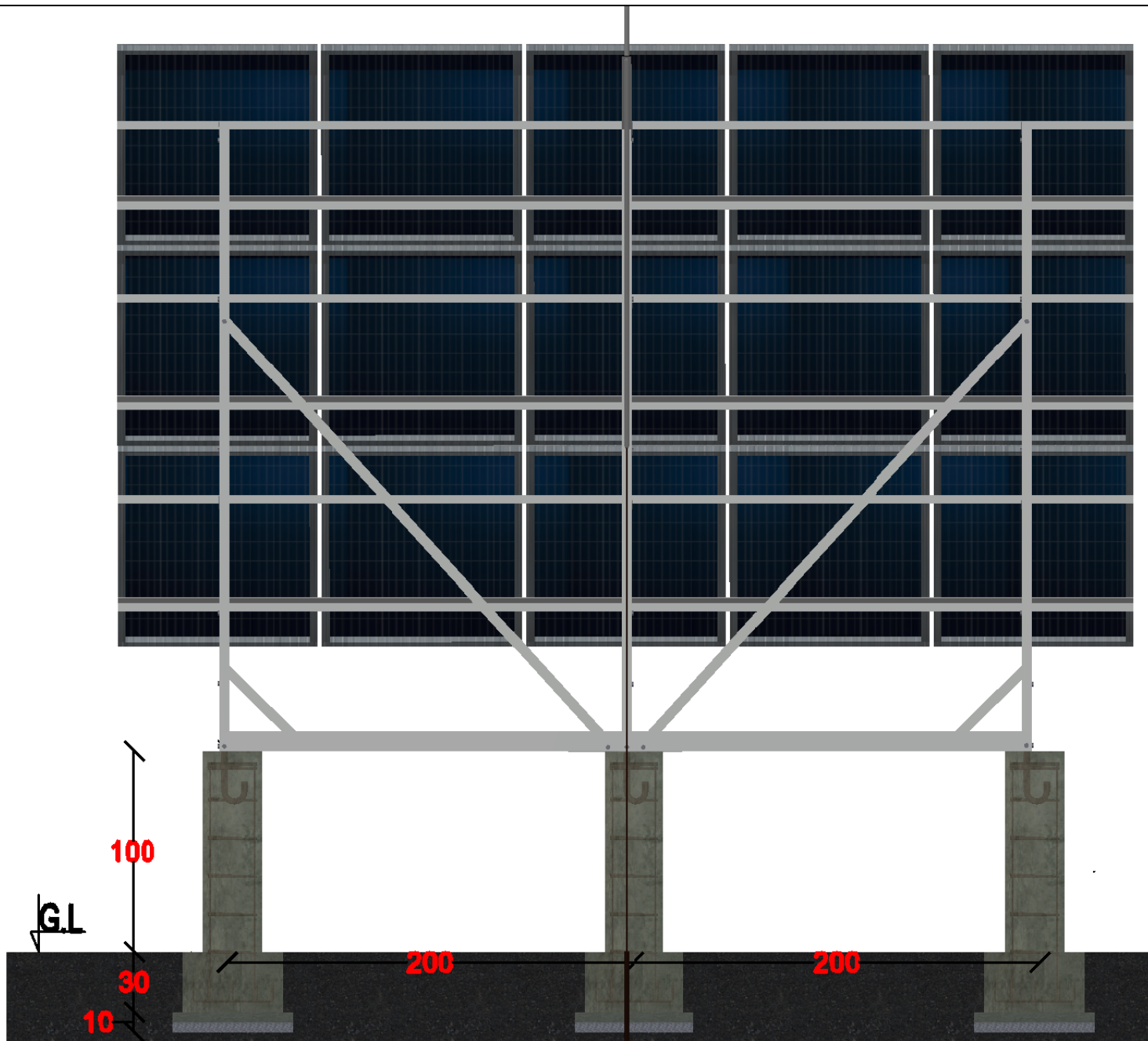

DACAAR / PROGRAMME	Funded By	Any	Village	Any	Drawn & Designed by	Survey/Design Team	Dim. Cm	Sheet Index 4 4	Project Title	Solar Design 3D
	Implemented By	DACAAR	District	Any	Reviewed By	Eng.Sayed Najib Jalal			Drawing Title	Back View
			Province	Any	Checked & Approved By	Eng. Abdul Wali Muslih			Date :	2024